

GB

CX3050-CX3060 Diagramme de câblage

Systeme de régulation EXcon

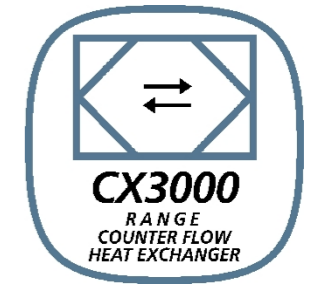

CX3050 & CX3060

0400103

400VAC - Pressure deicing
CX3050: 2500 m³/h
CX3060: 3300 m³/h

	Project: CX3050 & CX3060	Start date: 24-08-2022	Constructor: DKTSA	Page: 1	
		Revision date: 08-11-2023	Approved by: DKLEG	Previous page: 0	
Drawing number: 0400103	Revision: D	Page Title: Project information	Replaces: Rev. C	Scale: 1:1	Next page: 2
			EC no.:	Format:	Pages in total: 43

Page	Title	Page remarks	Last edit
1	Project information		22-12-2022
4	Standards		26-05-2023
5	Component overview		22-12-2022
10	E-box lay-out		26-05-2023
11	Terminals		21-12-2022
12	Main power		10-05-2023
13	Main power		10-05-2023
14	Terminal wiring EXcon Master		22-12-2022
15	Terminal wiring EXT module (1)		10-05-2023
16	Terminal wiring EXT module (2)		22-12-2022
17	PTH connections		22-12-2022
20	Configurations		22-12-2022
21	Configuration 1: No coils		22-12-2022
22	Configuration 2: HCW		22-12-2022
23	Configuration 3: HCE		22-12-2022
24	Configuration 4: CCW		22-12-2022
25	Configuration 5: Preheater		22-12-2022
26	Configuration 6: HCW+CCW		22-12-2022
27	Configuration 7: HCE+CCW		22-12-2022
28	Configuration 8: Preheater+HCW		22-12-2022
29	Configuration 9: Preheater+CCW		22-12-2022
30	Configuration 10: Preheater+HCE		22-12-2022
31	Configuration 11: Preheater+HCW+CCW		22-12-2022
32	Configuration 11: Preheater+HCW+CCW		22-12-2022
33	Configuration 12: Preheater+HCE+CCW		22-12-2022
34	Configuration 12: Preheater+HCE+CCW		22-12-2022
35	Configuration 13: C-O CW (Combi-Coil)		22-12-2022
36	Configuration 14: Preheater+Combi-Coil		22-12-2022
37	Optional accessories		16-06-2023

	Project: CX3050 & CX3060		Start date: 24-08-2022	Constructor: DKTSA	Page: 2
	Revision: D		Revision date: 08-11-2023	Approved by: DKLEG	Previous page: 1
Drawing number: 0400103	Page Title: Table of Contents		Replaces: Rev. C	Scale: 1:1	Next page: 3
			EC no.:	Format:	Pages in total: 43

Identification of wires by colour

400/230VAC Main current:

Phase: Black
 Neutral: Blue
 Earth: Green/Yellow

230/24VAC Pilot current:

Phase: Red
 Neutral: Blue
 Earth: Green/Yellow

24VDC Pilot current:

Positive (+): Red
 Negative (-): White

Signals:

Temperature: White
 Dry contact: White
 Analog: White
 Digital: White

Unknown potential:

All: Orange

Abbreviations of colours (according to IEC 60757)

Black	BK
Brown	BN
Red	RD
Orange	OG
Yellow	YE
Green	GN
Blue	BU
Light Blue	BU
Violet	VT
Gray	GY
White	WH
Pink	PK
Gold	GD
Turquoise	TQ
Silver	SR
Green/Yellow	GNYE

Other standards

Labelling of cables and cores (according to IEC 62491): Method CR

Method	Description
0	No labelling
A	Use of designated cables or cores
R	Identification labelling by means of reference designation (including cable number)
CL	Local-end connection labelling
CR	Remote-end connection labelling
CB	Both-end connection labelling
S	Signal labelling



Project:
CX3050 & CX3060

Start date:	24-08-2022	Constructor:	DKTSA	Page:	4
Revision date:	08-11-2023	Approved by:	DKLEG	Previous page:	3
Replaces:	Rev. C	Scale:	1:1	Next page:	5
EC no.:		Format:		Pages in total:	43

Drawing number:
0400103

Revision:
D

Page Title:
Standards

Component	Function	Position
+A1	Control system panel	/10.4
+A2	CX-unit	/10.1
+A3	Coil-box	/10.1
+A4	Customer accessory	/10.1
-BG1	PIR sensor	/37.5
-BQ1	CO2 sensor	/37.6
-BQ2	Air quality sensor	/38.8
-E1	Electrical post-heater	/23.4
-E2	Electrical pre-heater	/25.4
-E3	Combi-coil	/35.4
-F1	Fuse for Main supply	/12.3
-F2	Fuse for EXcon Master	/13.3
-F3	Fuse for external connections	/13.3
-F4	Fuse for Supply fan	/12.5
-F5	Fuse for Exhaust fan	/12.7
-K1	EXcon Master	/14.2
-K27	Extension modul (1)	/15.2
-K30	Extension modul (2)	/16.2
-M1	Supply fan	/12.5
-M2	Exhaust fan	/12.7
-M3	Bypass motor	/14.8
-M4	Circulation pump HCW	/22.1
-M5	Circulation pump CCW	/24.1
-M6	Circulation pump Combi-coil	/35.1
-P1	PTH: Measures pressure over the heat exchanger	/17.2
-P2	DUAL PTH: Supply airflow and extract filter pressure	/17.4
-P3	DUAL PTH: Extract airflow and outdoorfilter pressure	/17.7
-P4	PTH 4000: Constant pressure regulation supply air	/38.5
-P5	PTH 4000: Constant pressure regulation extract air	/38.7



Project:
CX3050 & CX3060

Start date: 24-08-2022 Constructor: DKTSA Page: 5

Revision date: 08-11-2023 Approved by: DKLEG Previous page: 4

Drawing number:
0400103

Revision:
D

Page Title:
Component overview

Replaces: Rev. C Scale: 1:1 Next page: 6

EC no.: Format: Pages in total: 43

Component	Function	Position
-PH1	HMI standard	/38.1
-PH2	HMI option	/38.7
-S1	Main switch	/12.1
-T1	Power supply 230VAC/2x24VDC	/13.3
-TE1.1	Extract air temperature	/17.5
-TE1.2	Exhaust air temperature	/17.8
-TE2.1	Outdoor air temperature	/17.8
-TE2.1-PRE	Outdoor air temperature	/25.7
-TE2.2	Supply air temperature	/21.7
-TE-OT	Outdoor temperature	/38.3
-TE-RPT	Clamp-on temp. sensor RPT HCW	/22.6
-TE-RPT-CC	Clamp-on temp. sensor RPT Combi-Co	/35.6
-TE-RT	Room temperature	/38.5
-TE-SPT	Clamp-on temp. sensor SPT CCW	/24.7
-W1	Main power supply cable	/12.1
-X1	Terminals for Main supply	/12.1
-X1_EXT(2)	Terminals for Coil-box	/16.2
-X2	Terminals for PE	/12.7
-X3	Terminal for fuses 24V	/13.3
-X4	Terminals for Circulation pumps 230V	/13.8
-X5	Terminals for External customer connections	/15.4
-X_BP	Plug bypass motor	/14.8
-X_FAN EX	Plug Exhaust fan	/12.7
-X_FAN SU	Plug Supply fan	/12.5
-X_RJ12.1	Modbus T-split	/14.8
-X_RJ12.2	Modbus T-split	/17.3
-X_RJ12.3	Modbus T-split	/38.2
-Y1	Valve HCW	/22.2
-Y2	Valve CCW	/24.2

	Project: CX3050 & CX3060	Start date: 24-08-2022	Constructor: DKTSA	Page: 6	
		Revision date: 08-11-2023	Approved by: DKLEG	Previous page: 5	
Drawing number: 0400103	Revision: D	Page Title: Component overview	Replaces: Rev. C	Scale: 1:1	Next page: 7
			EC no.:	Format:	Pages in total: 43

+A1

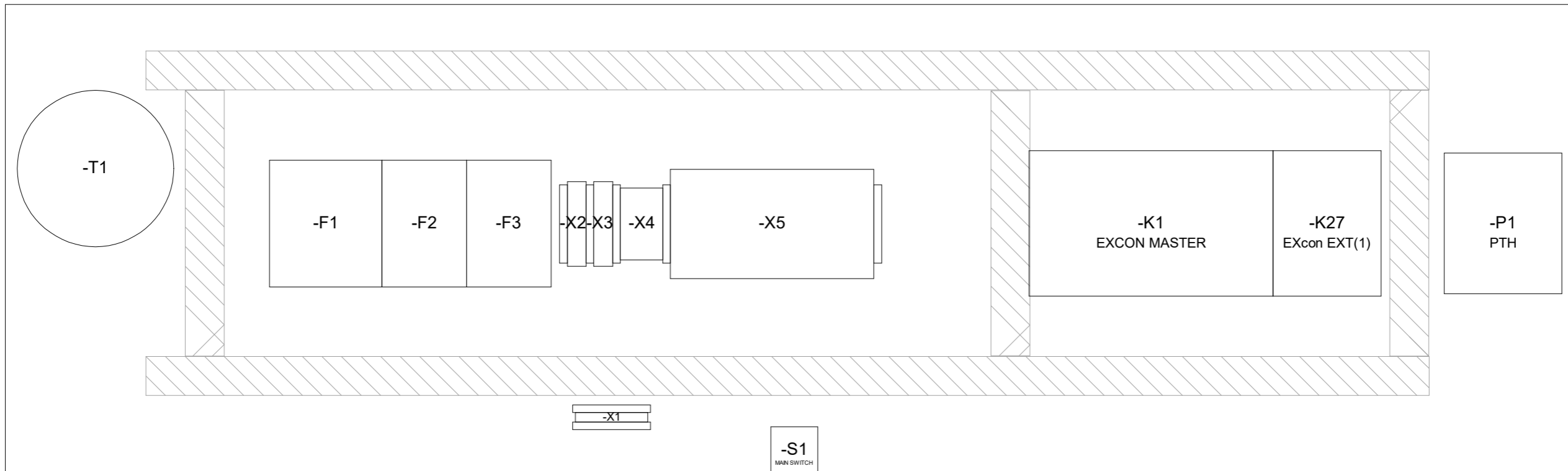

Project:
CX3050 & CX3060

Start date: 24-08-2022 Constructor: DKTSA Page: 10

Revision date: 08-11-2023 Approved by: DKLEG Previous page: 7

Drawing number:
0400103

Revision:
D

Page Title:
E-box lay-out

Replaces: Rev. C Scale: 1:3 Next page: 11

EC no.: Format: Pages in total: 43

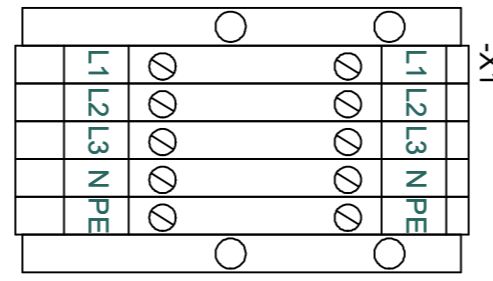
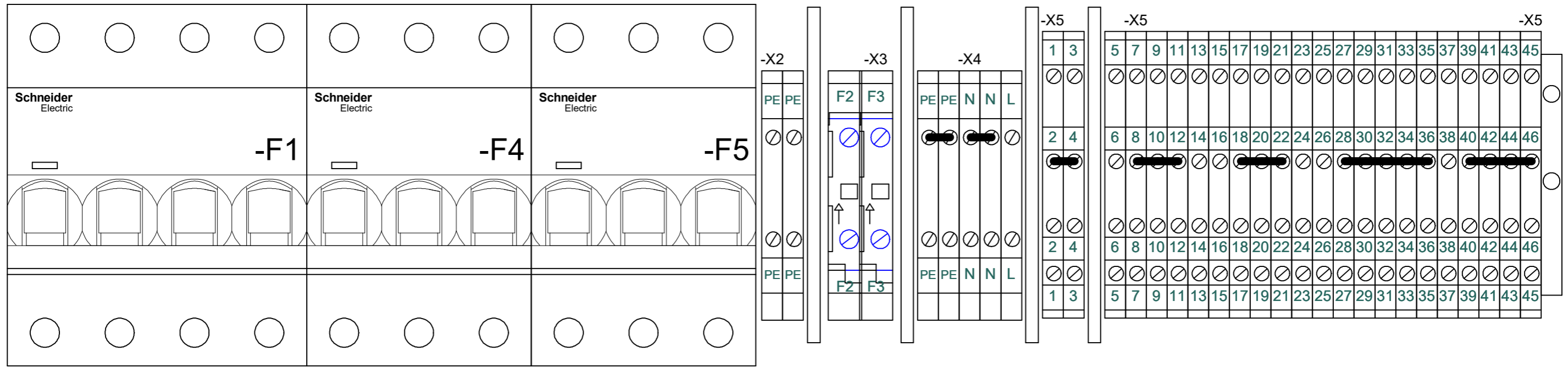

	Project:	Start date:	24-08-2022	Constructor:	DKTSA	Page:	11	
	CX3050 & CX3060	Revision date:	08-11-2023	Approved by:	DKLEG	Previous page:	10	
Drawing number:	Revision:	Page Title:	Replaces:	Rev. C	Scale:	1:1	Next page:	12
0400103	D	Terminals	EC no.:		Format:		Pages in total:	43

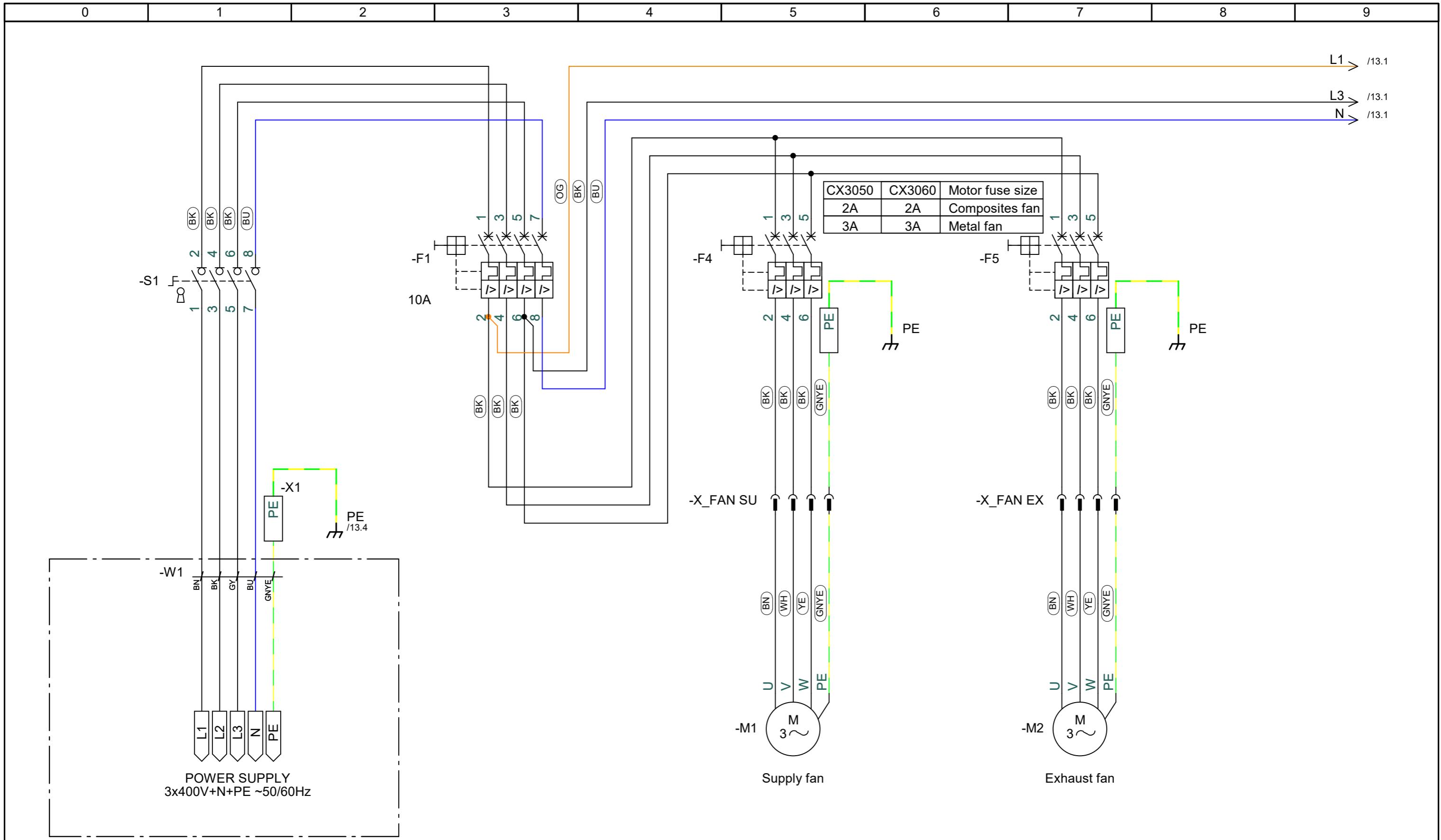

	Project:	CX3050 & CX3060	Start date:	24-08-2022	Constructor:	DKTSA	Page:	12
	Drawing number:	0400103	Revision date:	08-11-2023	Approved by:	DKLEG	Previous page:	11
Revision:	D	Page Title:	Replaces:	Rev. C	Scale:	1:1	Next page:	13
		Main power	EC no.:		Format:		Pages in total:	43

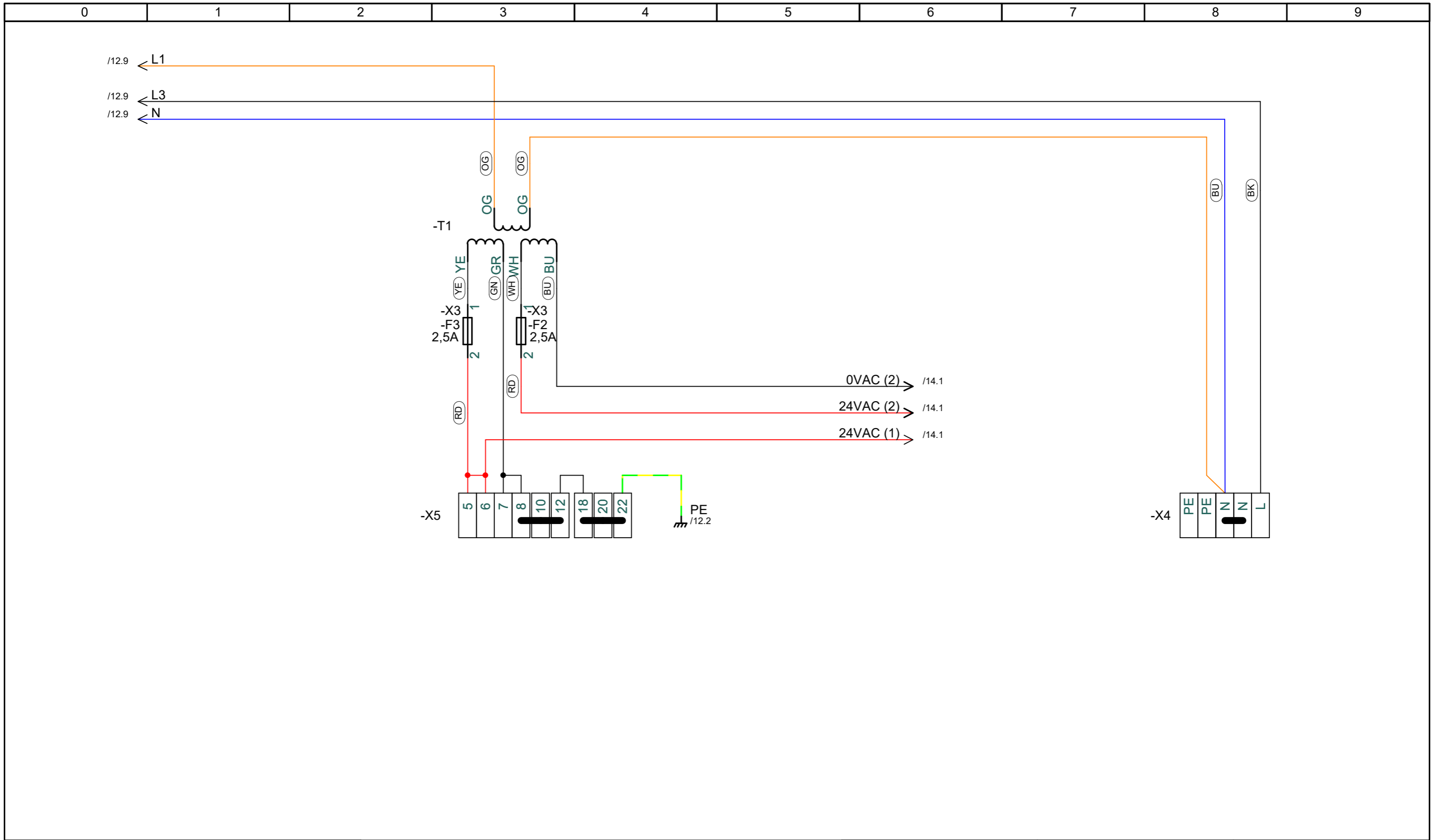

	Project:	CX3050 & CX3060	Start date:	24-08-2022	Constructor:	DKTSA	Page:	13			
	Drawing number:	0400103	Revision:	D	Page Title:	Main power	Revision date:	08-11-2023	Approved by:	DKLEG	Previous page:
			Replaces:	Rev. C	Scale:	1:1	Next page:	14			
			EC no.:		Format:		Pages in total:	43			

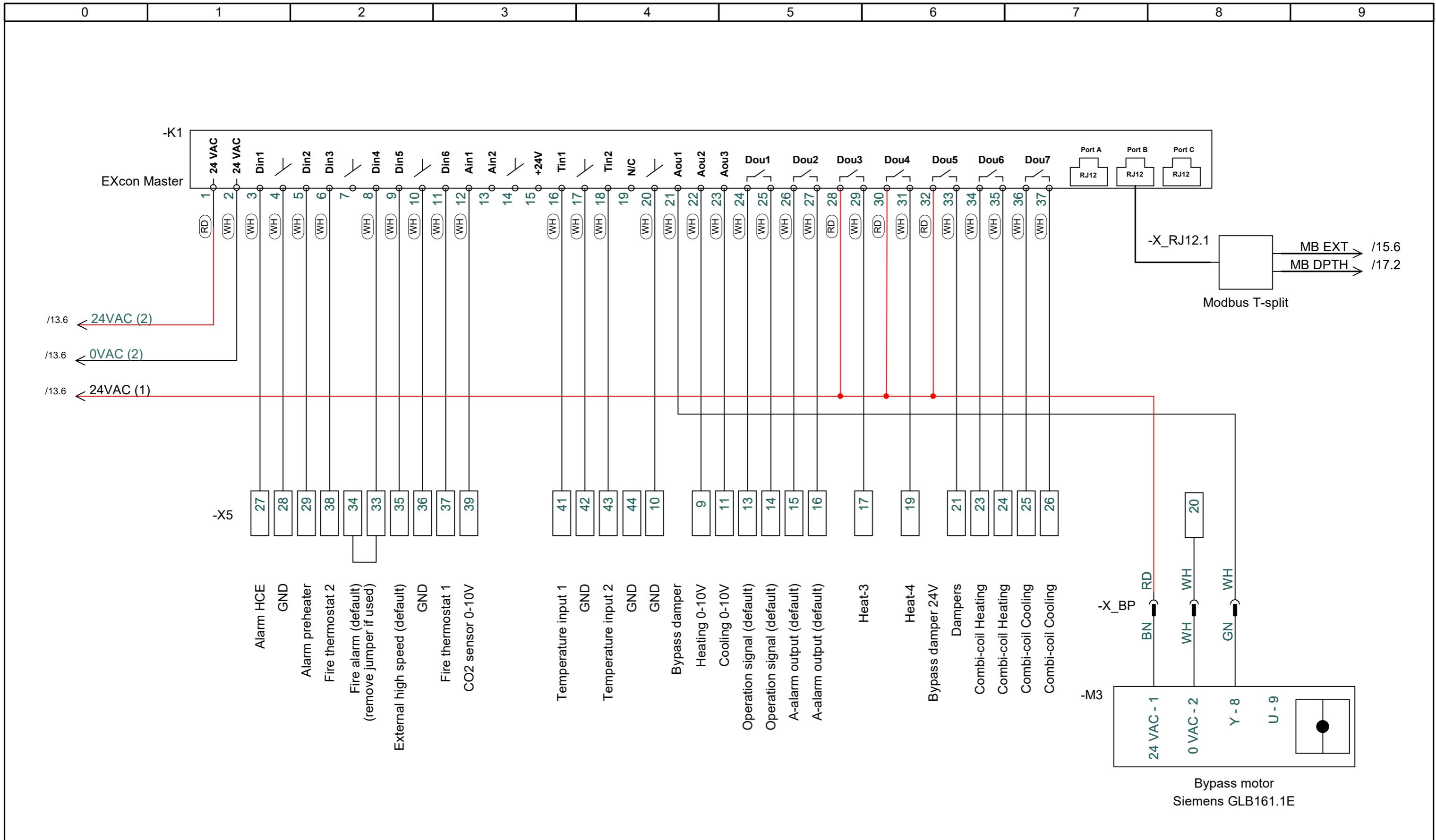

	Project:	Start date:	24-08-2022	Constructor:	DKTSA	Page:	14	
	CX3050 & CX3060	Revision date:	08-11-2023	Approved by:	DKLEG	Previous page:	13	
Drawing number:	Revision:	Page Title:	Replaces:	Rev. C	Scale:	1:1	Next page:	15
0400103	D	Terminal wiring EXcon Master	EC no.:		Format:		Pages in total:	43

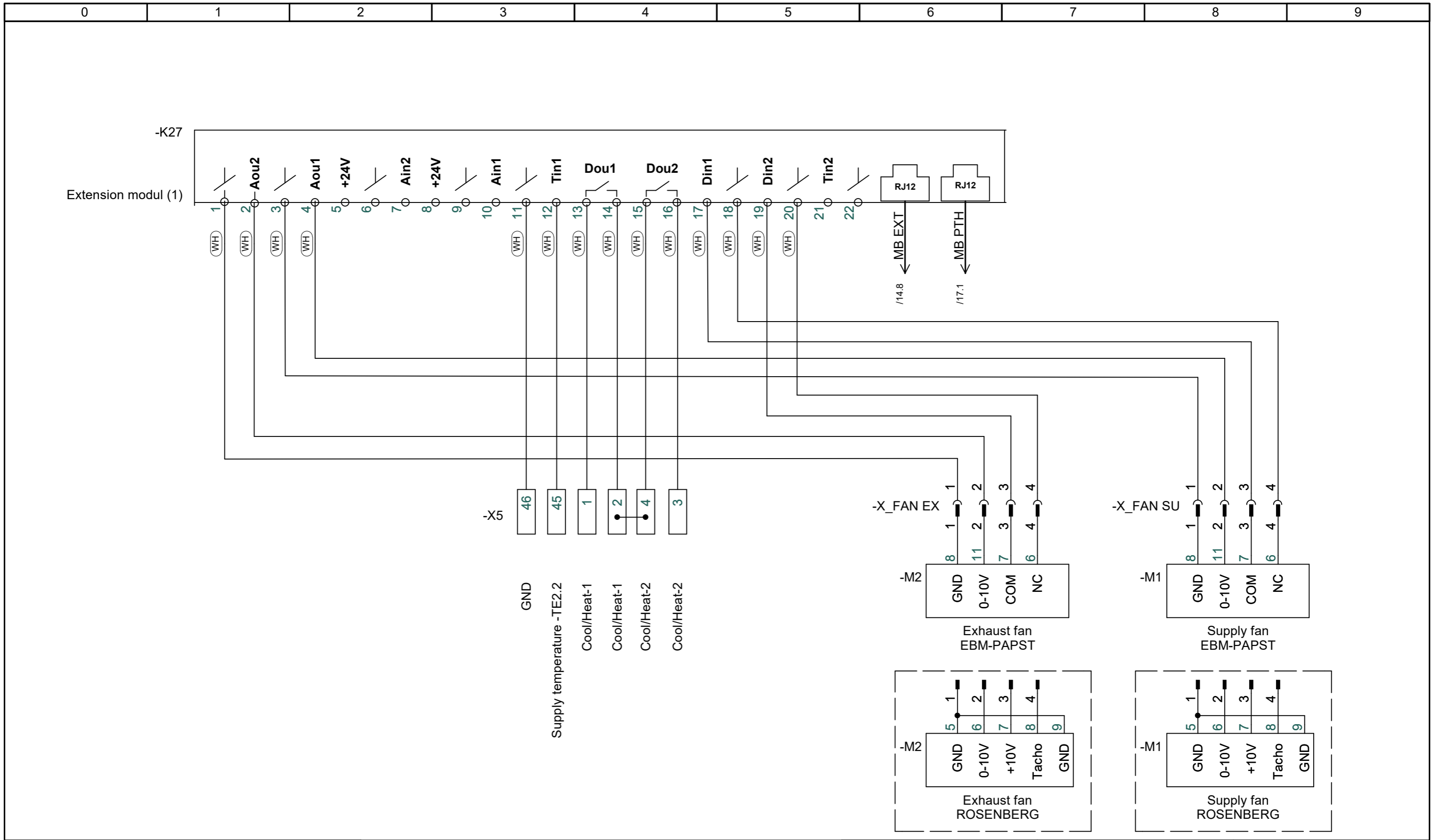

	Project:	Start date:	24-08-2022	Constructor:	DKTSA	Page:	15	
	CX3050 & CX3060	Revision date:	08-11-2023	Approved by:	DKLEG	Previous page:	14	
Drawing number:	Revision:	Page Title:	Replaces:	Rev. C	Scale:	1:1	Next page:	16
0400103	D	Terminal wiring EXT module (1)	EC no.:		Format:		Pages in total:	43

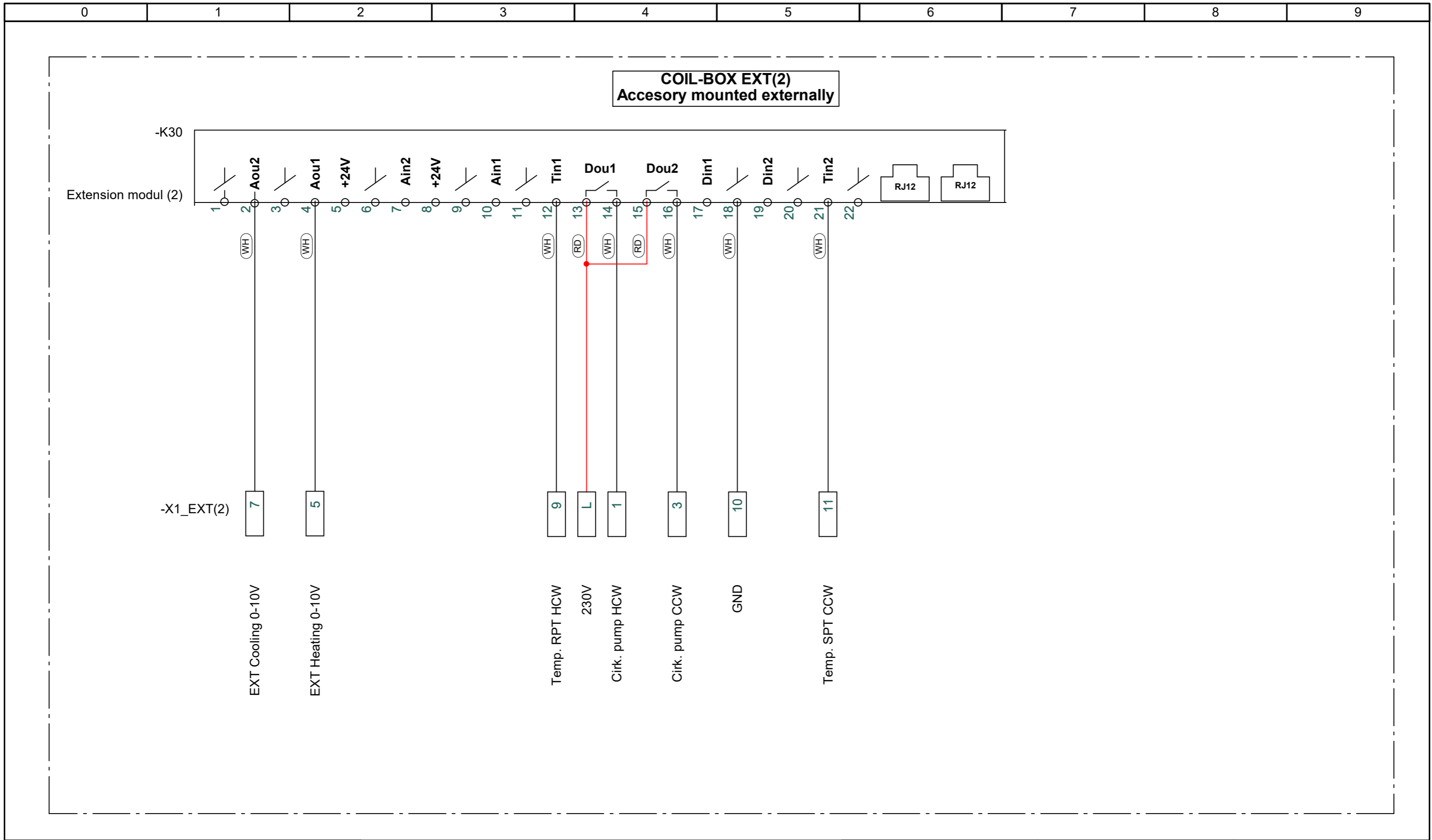

	Project:	Start date:	24-08-2022	Constructor:	DKTSA	Page:	16
	CX3050 & CX3060	Revision date:	08-11-2023	Approved by:	DKLEG	Previous page:	15
Drawing number:	Revision:	Page Title:		Replaces:	Rev. C	Scale:	1:1
0400103	D	Terminal wiring EXT module (2)		EC no.:	Format:	Next page:	17
						Pages in total:	43

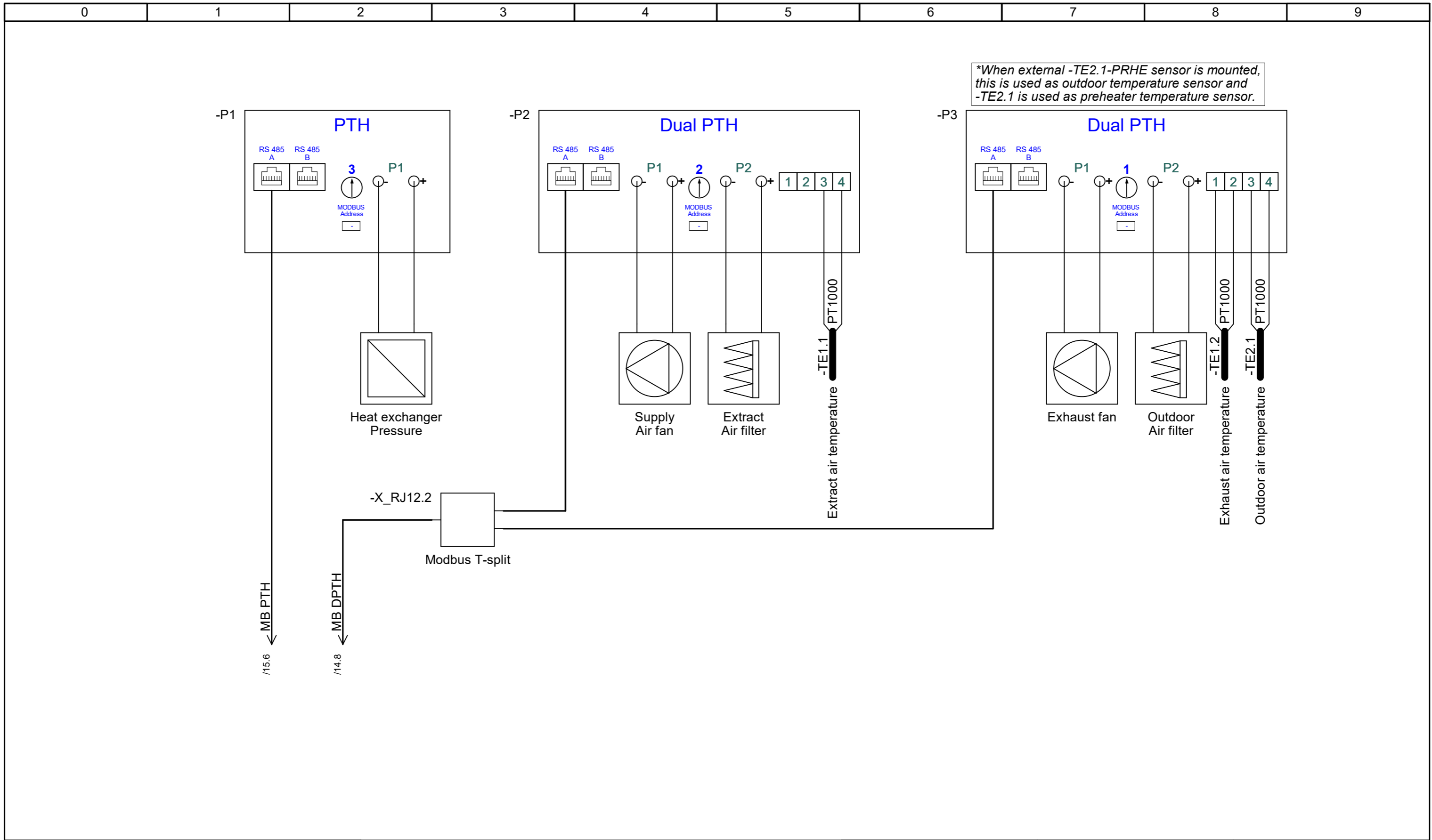

	Project:	Start date:	24-08-2022	Constructor:	DKTSA	Page:	17	
	CX3050 & CX3060	Revision date:	08-11-2023	Approved by:	DKLEG	Previous page:	16	
Drawing number:	Revision:	Page Title:	Replaces:	Rev. C	Scale:	1:1	Next page:	20
0400103	D	PTH connections	EC no.:		Format:		Pages in total:	43

Configurations

	Project: CX3050 & CX3060	Start date: 24-08-2022	Constructor: DKTSA	Page: 20	
		Revision date: 08-11-2023	Approved by: DKLEG	Previous page: 17	
Drawing number: 0400103	Revision: D	Page Title: Configurations	Replaces: Rev. C	Scale: 1:1	Next page: 21
			EC no.:	Format:	Pages in total: 43

Configuration 1: No Coils

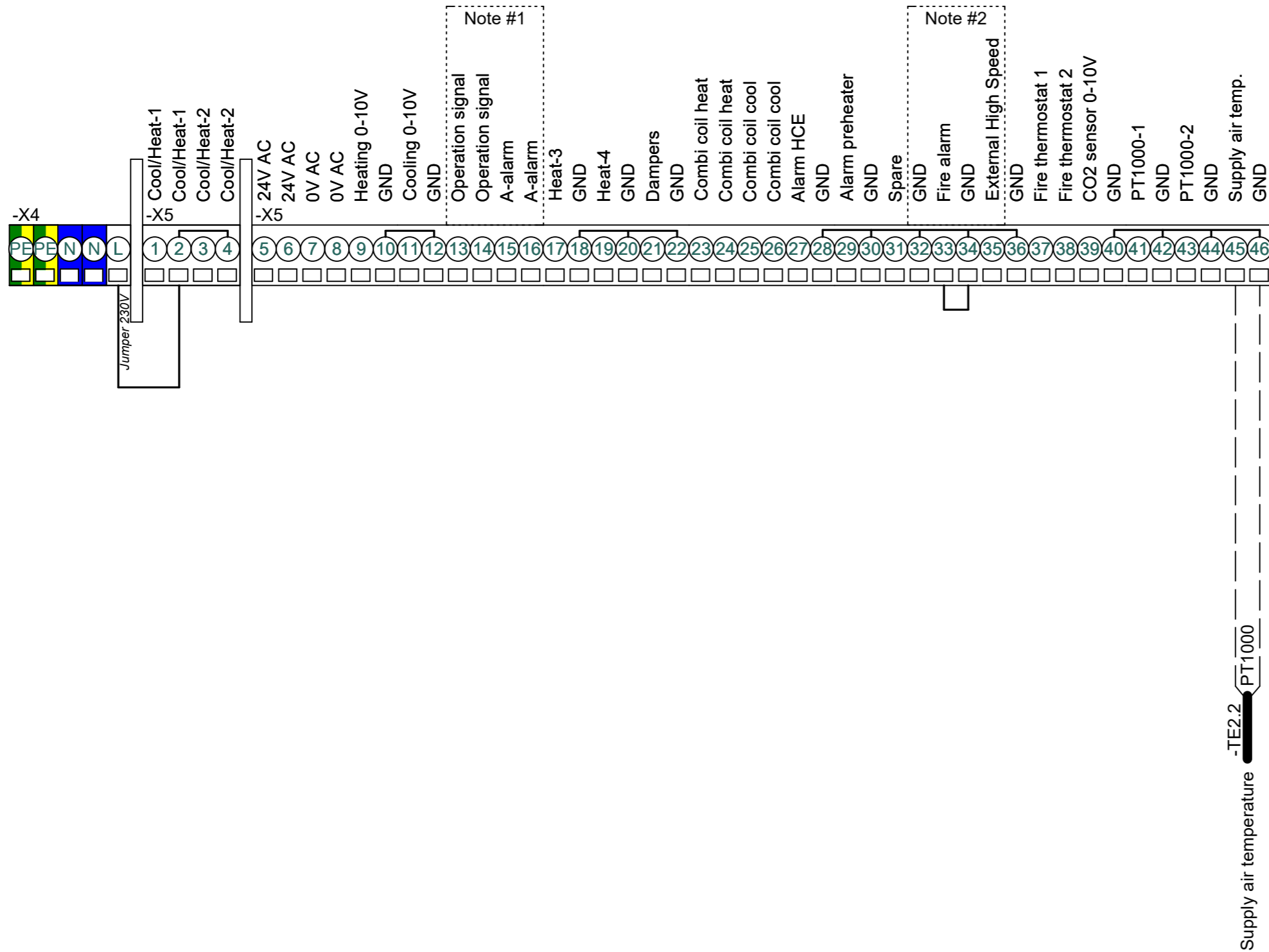

Note #1
 Default configuration.
 Can be changed to:
 - B-alarm output
 - Alarm reset
 - Summer operation
 - Summer night cooling

Note #2
 Default configuration.
 Can be changed to:
 - AHU STOP
 - Low speed
 - Medium speed
 - Frost alarm
 - External start
 - External reset alarms
 If used remove jumper

* Supply air temperature sensor must be mounted in supply air duct after heating and cooling coils

	Project:	CX3050 & CX3060	Start date:	24-08-2022	Constructor:	DKTSA	Page:	21			
	Drawing number:	0400103	Revision:	D	Page Title:	Configuration 1: No coils	Revision date:	08-11-2023	Approved by:	DKLEG	Previous page:
					Replaces:	Rev. C	Scale:	1:1	Next page:	22	
					EC no.:		Format:		Pages in total:	43	

Configuration 2: Water Heating Coil

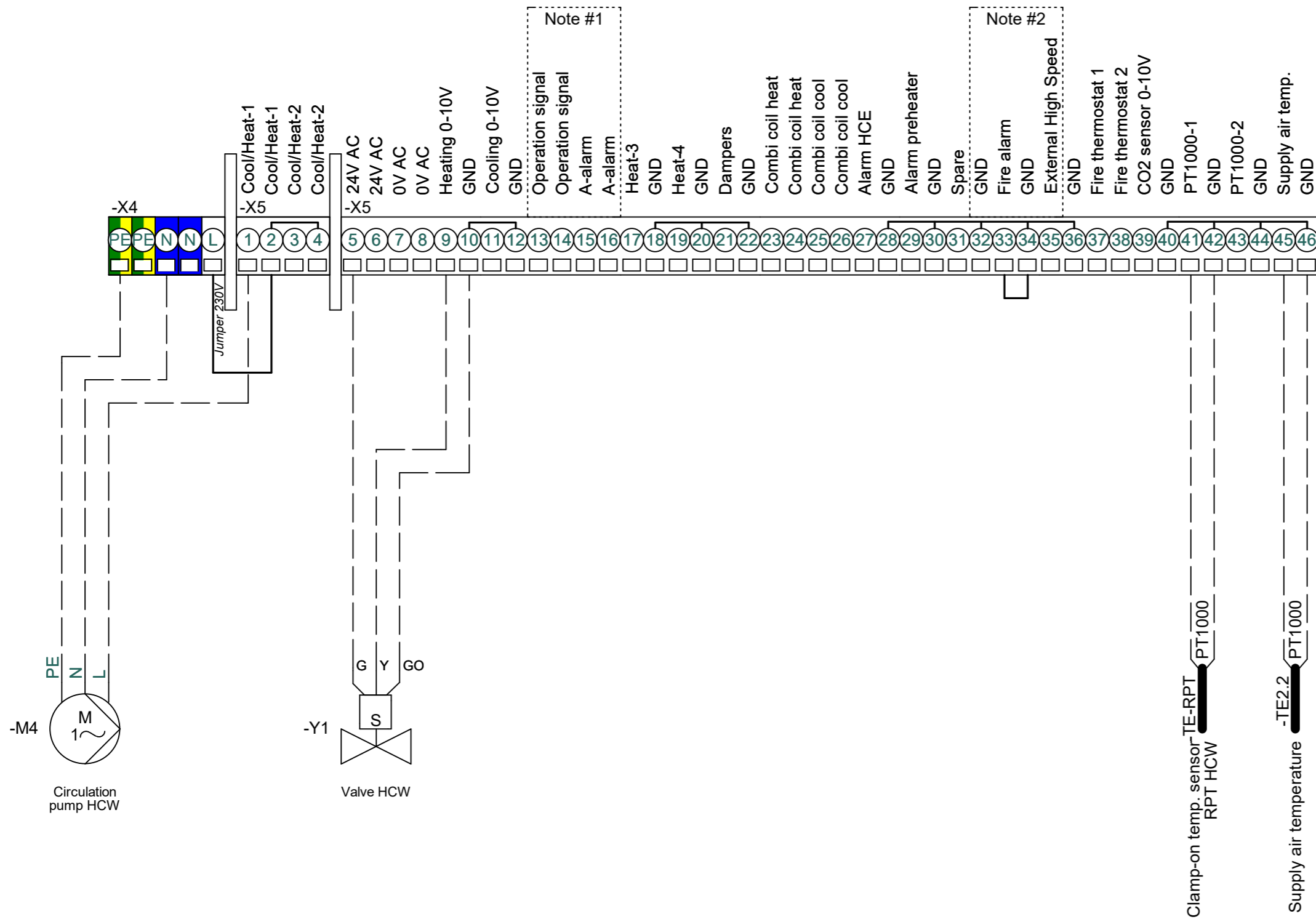

Note #1
 Default configuration.
 Can be changed to:
 - B-alarm output
 - Alarm reset
 - Summer operation
 - Summer night cooling

Note #2
 Default configuration.
 Can be changed to:
 - AHU STOP
 - Low speed
 - Medium speed
 - Frost alarm
 - External start
 - External reset alarms
 If used remove jumper

* Supply air temperature sensor must be mounted in supply air duct after heating and cooling coils

	Project:	CX3050 & CX3060	Start date:	24-08-2022	Constructor:	DKTSA	Page:	22			
	Drawing number:	0400103	Revision:	D	Page Title:	Configuration 2: HCW	Revision date:	08-11-2023	Approved by:	DKLEG	Previous page:
					Replaces:	Rev. C	Scale:	1:1	Next page:	23	
					EC no.:		Format:		Pages in total:	43	

Configuration 3: Electric Heating Coil

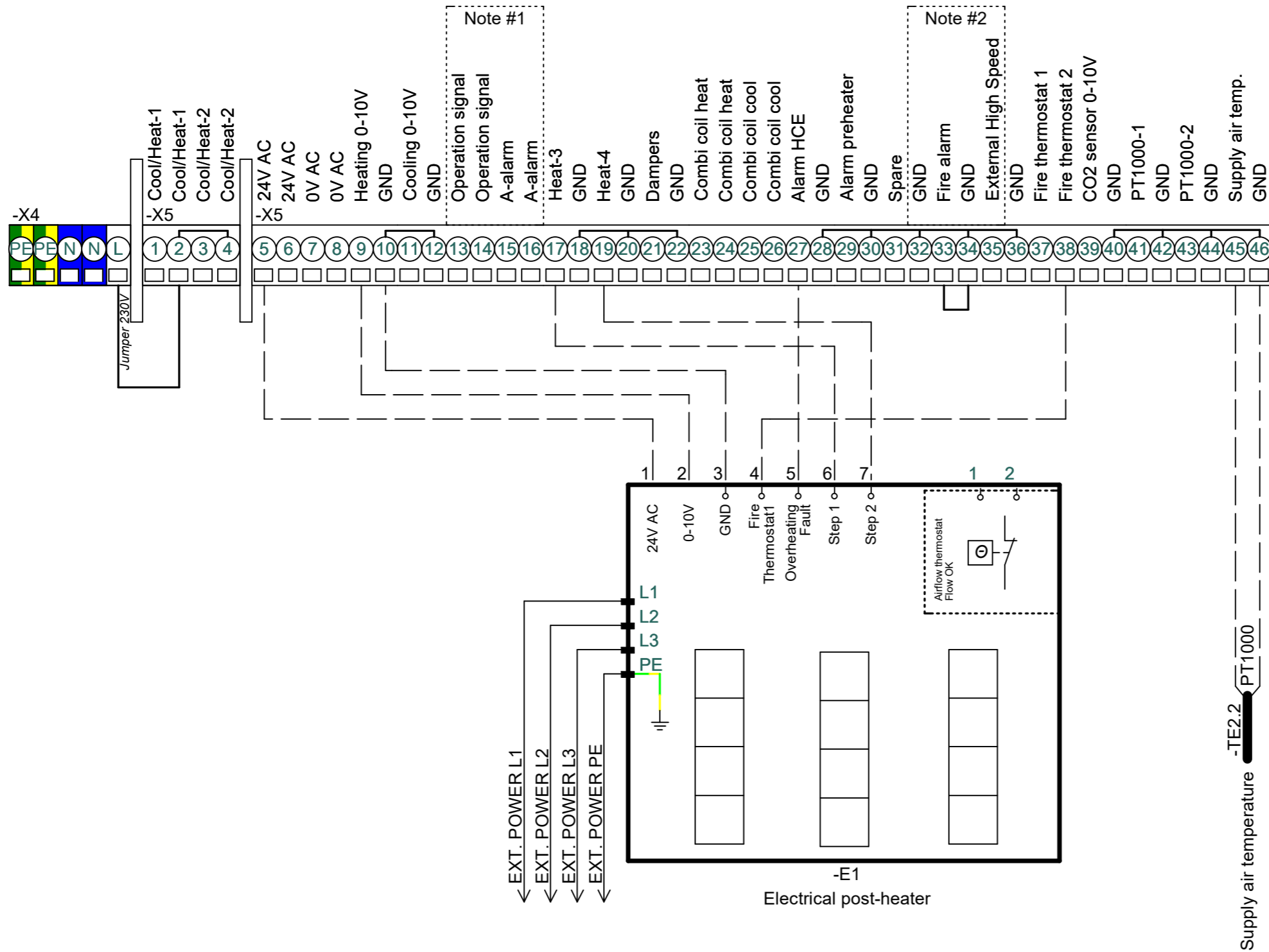

Note #1
 Default configuration.
 Can be changed to:
 - B-alarm output
 - Alarm reset
 - Summer operation
 - Summer night cooling

Note #2
 Default configuration.
 Can be changed to:
 - AHU STOP
 - Low speed
 - Medium speed
 - Frost alarm
 - External start
 - External reset alarms
 If used remove jumper

* Heater Step 2 are only used in the high performance heaters

* Supply air temperature sensor must be mounted in supply air duct after heating and cooling coils

	Project:	CX3050 & CX3060	Start date:	24-08-2022	Constructor:	DKTSA	Page:	23			
	Drawing number:	0400103	Revision:	D	Page Title:	Configuration 3: HCE	Revision date:	08-11-2023	Approved by:	DKLEG	Previous page:
					Replaces:	Rev. C	Scale:	1:1	Next page:	24	
					EC no.:		Format:		Pages in total:	43	

Configuration 4: Water Cooling Coil

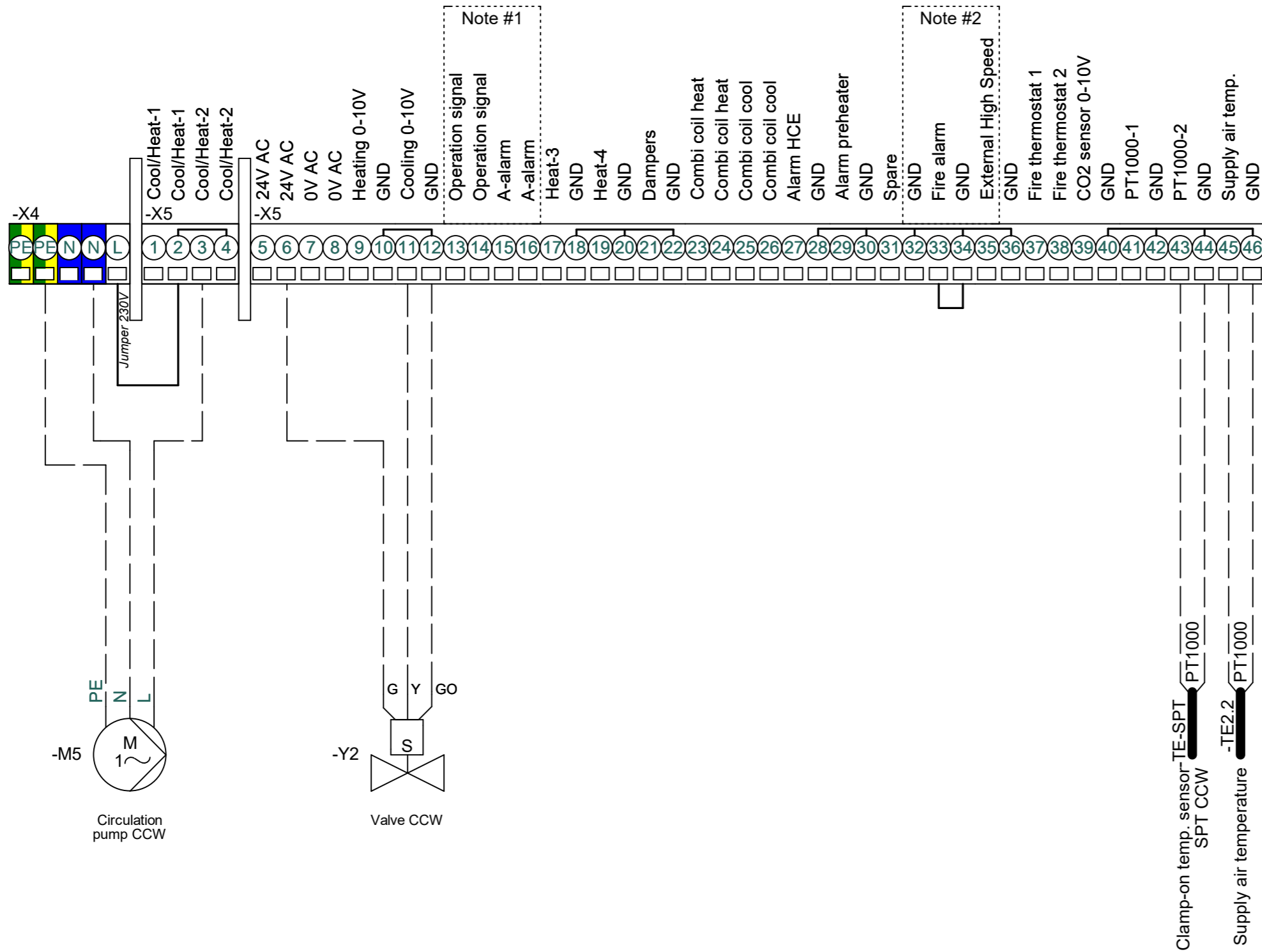

Note #1
 Default configuration.
 Can be changed to:
 - B-alarm output
 - Alarm reset
 - Summer operation
 - Summer night cooling

Note #2
 Default configuration.
 Can be changed to:
 - AHU STOP
 - Low speed
 - Medium speed
 - Frost alarm
 - External start
 - External reset alarms
 If used remove jumper

* Supply air temperature sensor must be mounted in supply air duct after heating and cooling coils

	Project: CX3050 & CX3060	Start date: 24-08-2022	Constructor: DKTSA	Page: 24
	Drawing number: 0400103	Revision: D	Revision date: 08-11-2023	Approved by: DKLEG
Page Title: Configuration 4: CCW		Replaces: Rev. C	Scale: 1:1	Next page: 25
		EC no.:	Format:	Pages in total: 43

Configuration 5: Electric Pre-heater

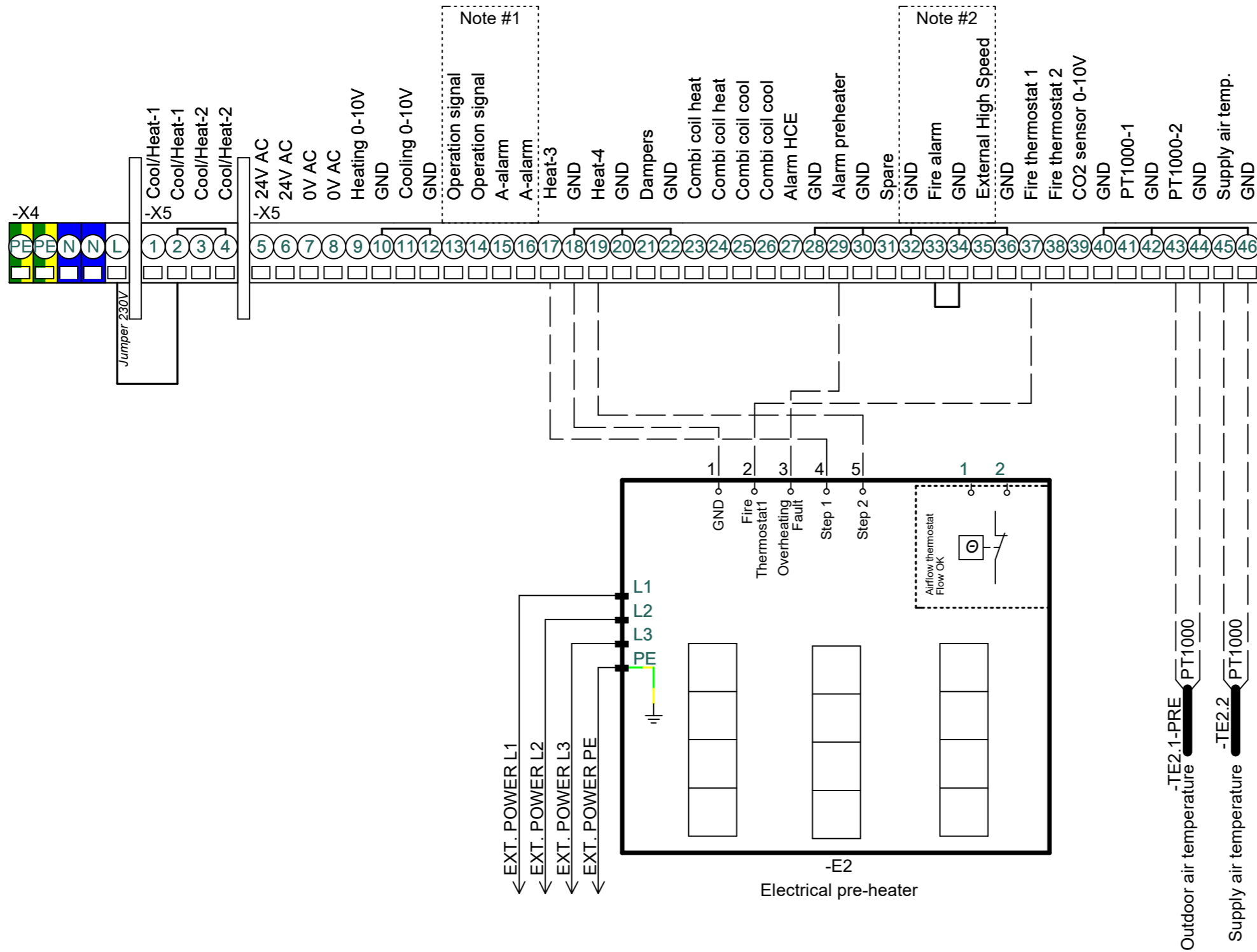

Note #1
 Default configuration.
 Can be changed to:
 - B-alarm output
 - Alarm reset
 - Summer operation
 - Summer night cooling

Note #2
 Default configuration.
 Can be changed to:
 - AHU STOP
 - Low speed
 - Medium speed
 - Frost alarm
 - External start
 - External reset alarms
 If used remove jumper

* Heater Step 2 are only used in the high performance heaters

* Outdoor air temperature sensor must be mounted in the outside air duct, before the preheating coil.

* Supply air temperature sensor must be mounted in supply air duct after heating and cooling coils

	Project:	CX3050 & CX3060	Start date:	24-08-2022	Constructor:	DKTSA	Page:	25			
	Drawing number:	0400103	Revision:	D	Page Title:	Configuration 5: Preheater	Revision date:	08-11-2023	Approved by:	DKLEG	Previous page:
					Replaces:	Rev. C	Scale:	1:1	Next page:	26	
					EC no.:		Format:		Pages in total:	43	

Configuration 6: Water Heating Coil + Water cooling coil

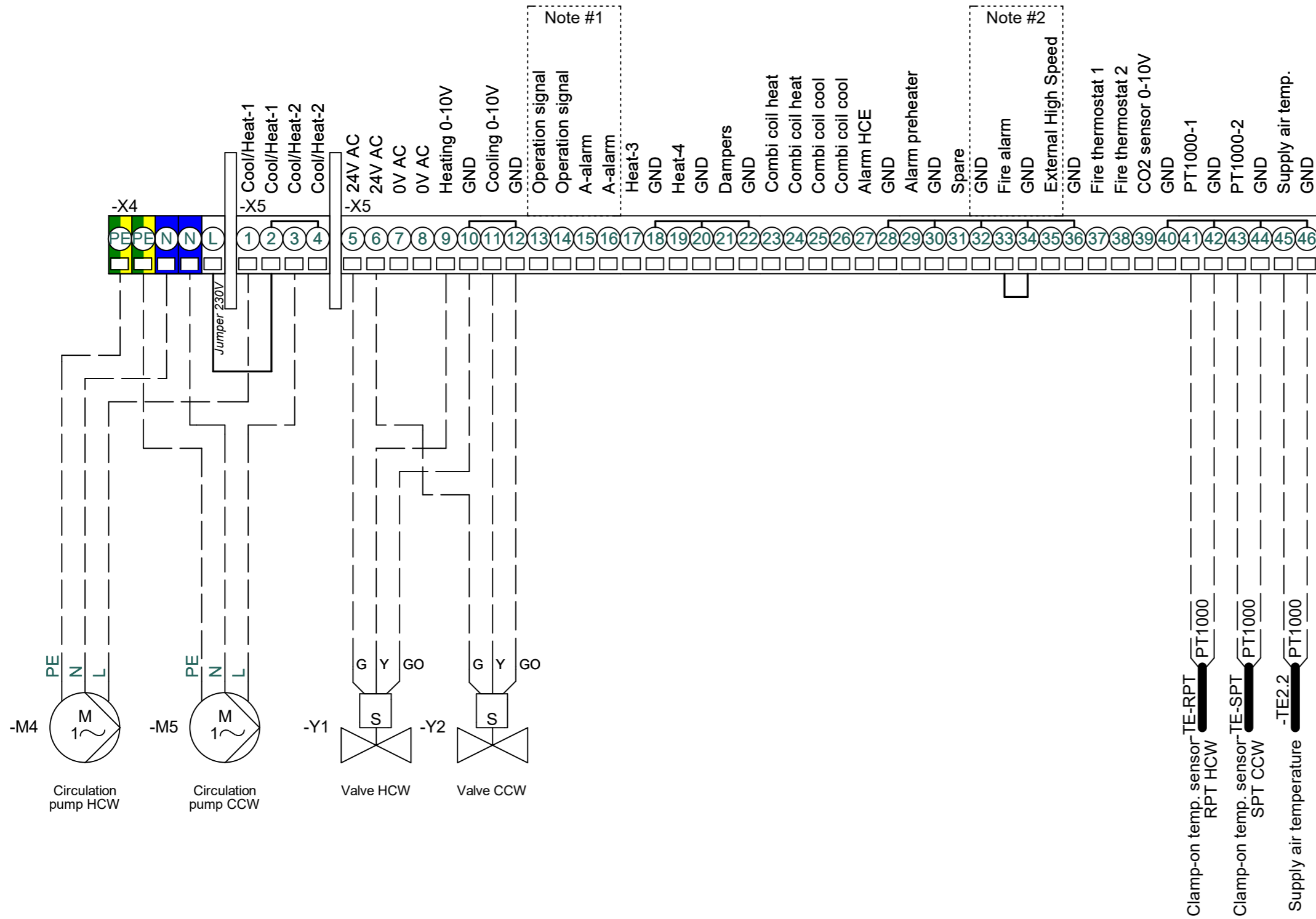

Note #1
 Default configuration.
 Can be changed to:
 - B-alarm output
 - Alarm reset
 - Summer operation
 - Summer night cooling

Note #2
 Default configuration.
 Can be changed to:
 - AHU STOP
 - Low speed
 - Medium speed
 - Frost alarm
 - External start
 - External reset alarms
 If used remove jumper

* Supply air temperature sensor must be mounted in supply air duct after heating and cooling coils

	Project:	Start date:	24-08-2022	Constructor:	DKTSA	Page:	26
	CX3050 & CX3060	Revision date:	08-11-2023	Approved by:	DKLEG	Previous page:	25
Drawing number:	Revision:	Page Title:	Replaces:	Rev. C	Scale:	1:1	Next page:
0400103	D	Configuration 6: HCW+CCW	EC no.:		Format:		Pages in total:
							43

Connections configuration 7: Electric Heating Coil + Water Cooling Coil

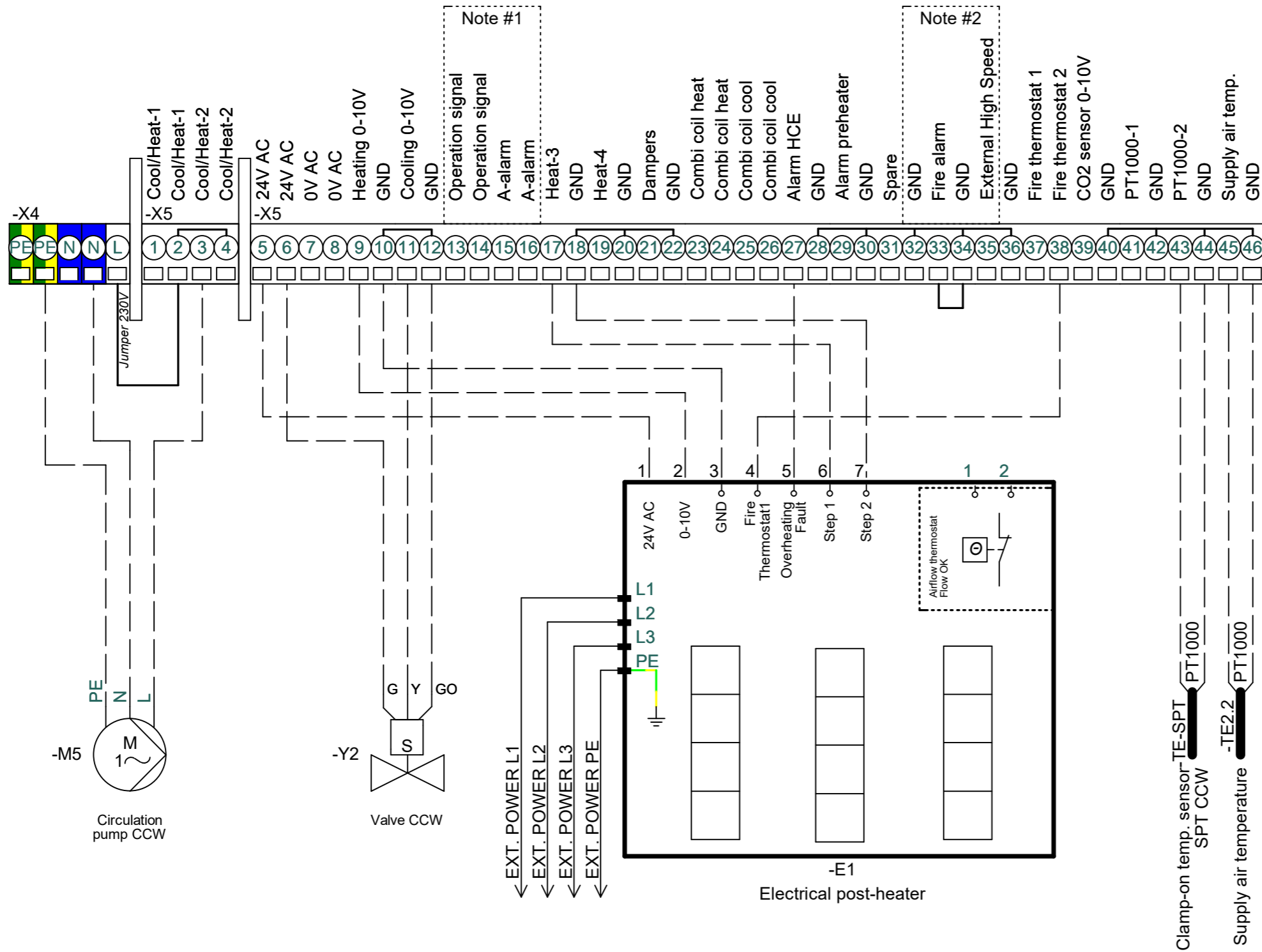

Note #1
 Default configuration.
 Can be changed to:
 - B-alarm output
 - Alarm reset
 - Summer operation
 - Summer night cooling

Note #2
 Default configuration.
 Can be changed to:
 - AHU STOP
 - Low speed
 - Medium speed
 - Frost alarm
 - External start
 - External reset alarms
 If used remove jumper

* Heater Step 2 are only used in the high performance heaters

* Supply air temperature sensor must be mounted in supply air duct after heating and cooling coils

	Project:	CX3050 & CX3060	Start date:	24-08-2022	Constructor:	DKTSA	Page:	27			
	Drawing number:	0400103	Revision:	D	Page Title:	Configuration 7: HCE+CCW	Revision date:	08-11-2023	Approved by:	DKLEG	Previous page:
					Replaces:	Rev. C	Scale:	1:1	Next page:	28	
					EC no.:		Format:		Pages in total:	43	

Connections configuration 8: Electric Preheating Coil + Water Heating Coil

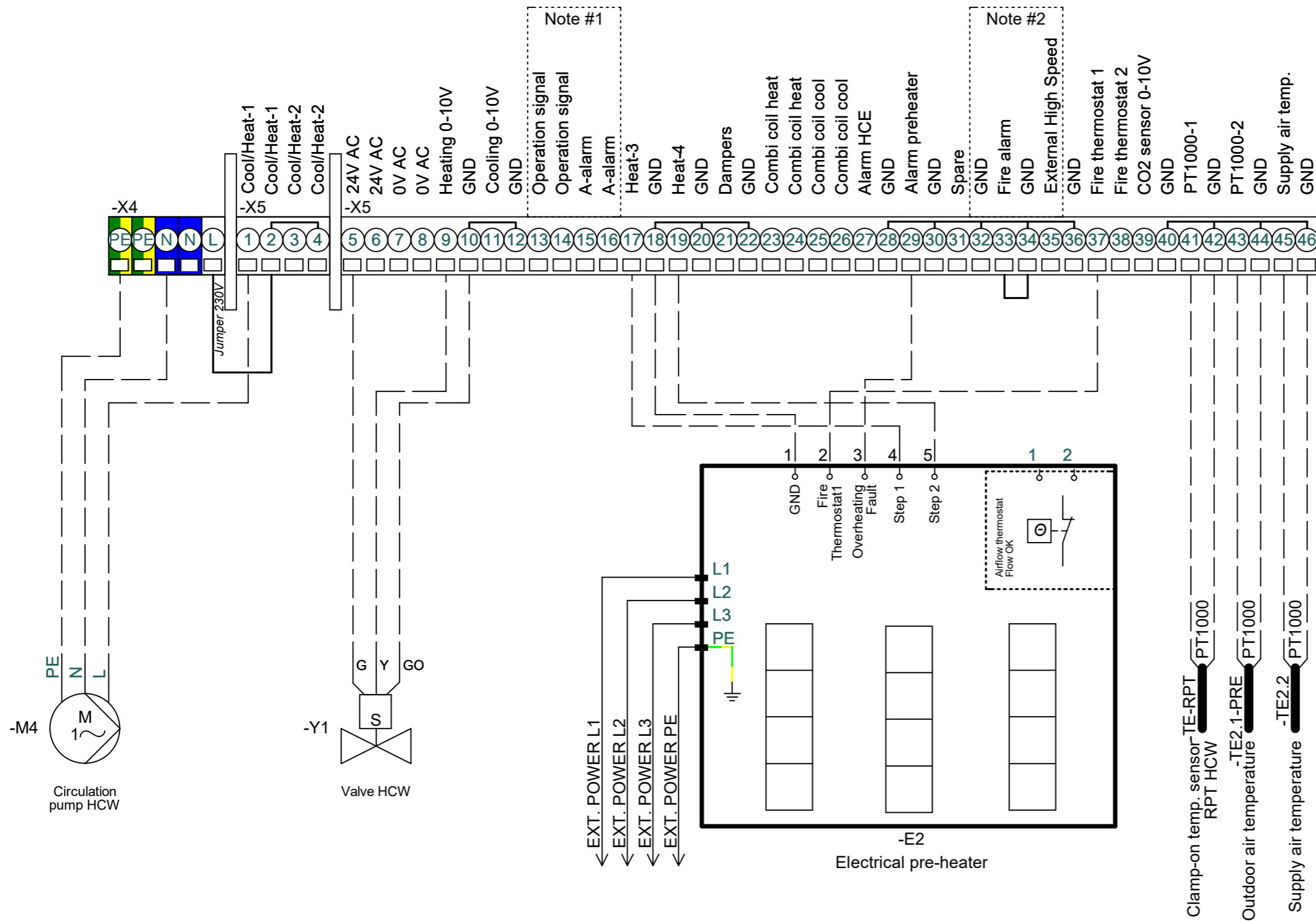

Note #1
 Default configuration.
 Can be changed to:
 - B-alarm output
 - Alarm reset
 - Summer operation
 - Summer night cooling

Note #2
 Default configuration.
 Can be changed to:
 - AHU STOP
 - Low speed
 - Medium speed
 - Frost alarm
 - External start
 - External reset alarms
 If used remove jumper

* Heater Step 2 are only used in the high performance heaters

* Outdoor air temperature sensor must be mounted in the outside air duct, before the preheating coil.

* Supply air temperature sensor must be mounted in supply air duct after heating and cooling coils

	Project:	CX3050 & CX3060	Start date:	24-08-2022	Constructor:	DKTSA	Page:	28				
	Drawing number:	0400103	Revision:	D	Page Title:	Configuration 8: Preheater+HCW	Revision date:	08-11-2023	Approved by:	DKLEG	Previous page:	27
							Replaces:	Rev. C	Scale:	1:1	Next page:	29
							EC no.:		Format:		Pages in total:	43

Connections configuration 9: Electric Preheating Coil + Water Cooling Coil

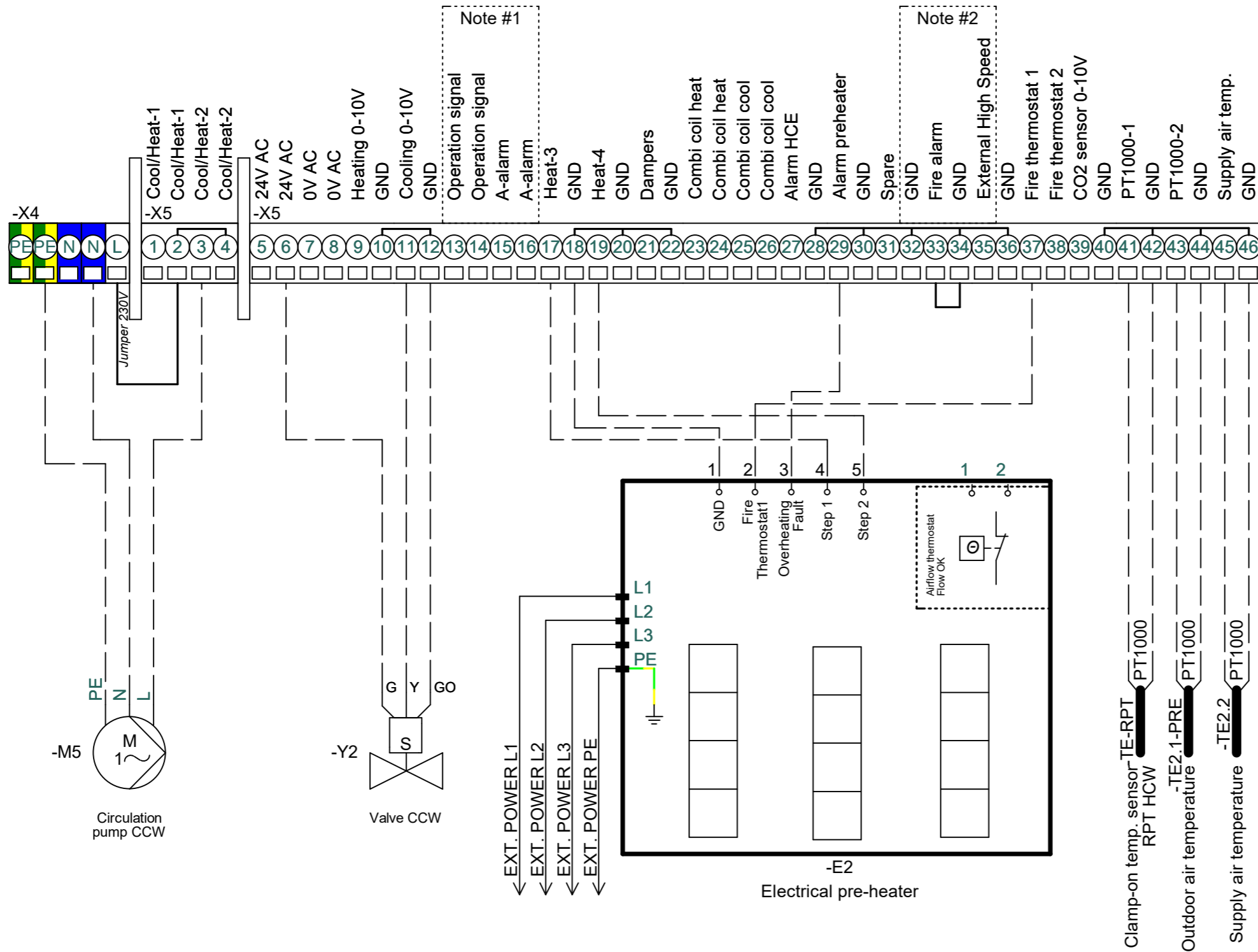

Note #1
 Default configuration.
 Can be changed to:
 - B-alarm output
 - Alarm reset
 - Summer operation
 - Summer night cooling

Note #2
 Default configuration.
 Can be changed to:
 - AHU STOP
 - Low speed
 - Medium speed
 - Frost alarm
 - External start
 - External reset alarms
 If used remove jumper

* Heater Step 2 are only used in the high performance heaters

* Outdoor air temperature sensor must be mounted in the outside air duct, before the preheating coil.

* Supply air temperature sensor must be mounted in supply air duct after heating and cooling coils

	Project:	CX3050 & CX3060	Start date:	24-08-2022	Constructor:	DKTSA	Page:	29			
	Drawing number:	0400103	Revision:	D	Page Title:	Configuration 9: Preheater+CCW	Revision date:	08-11-2023	Approved by:	DKLEG	Previous page:
					Replaces:	Rev. C	Scale:	1:1	Next page:	30	
					EC no.:		Format:		Pages in total:	43	

Connections configuration 10: Electric Preheating Coil + Electric Postheating Coil

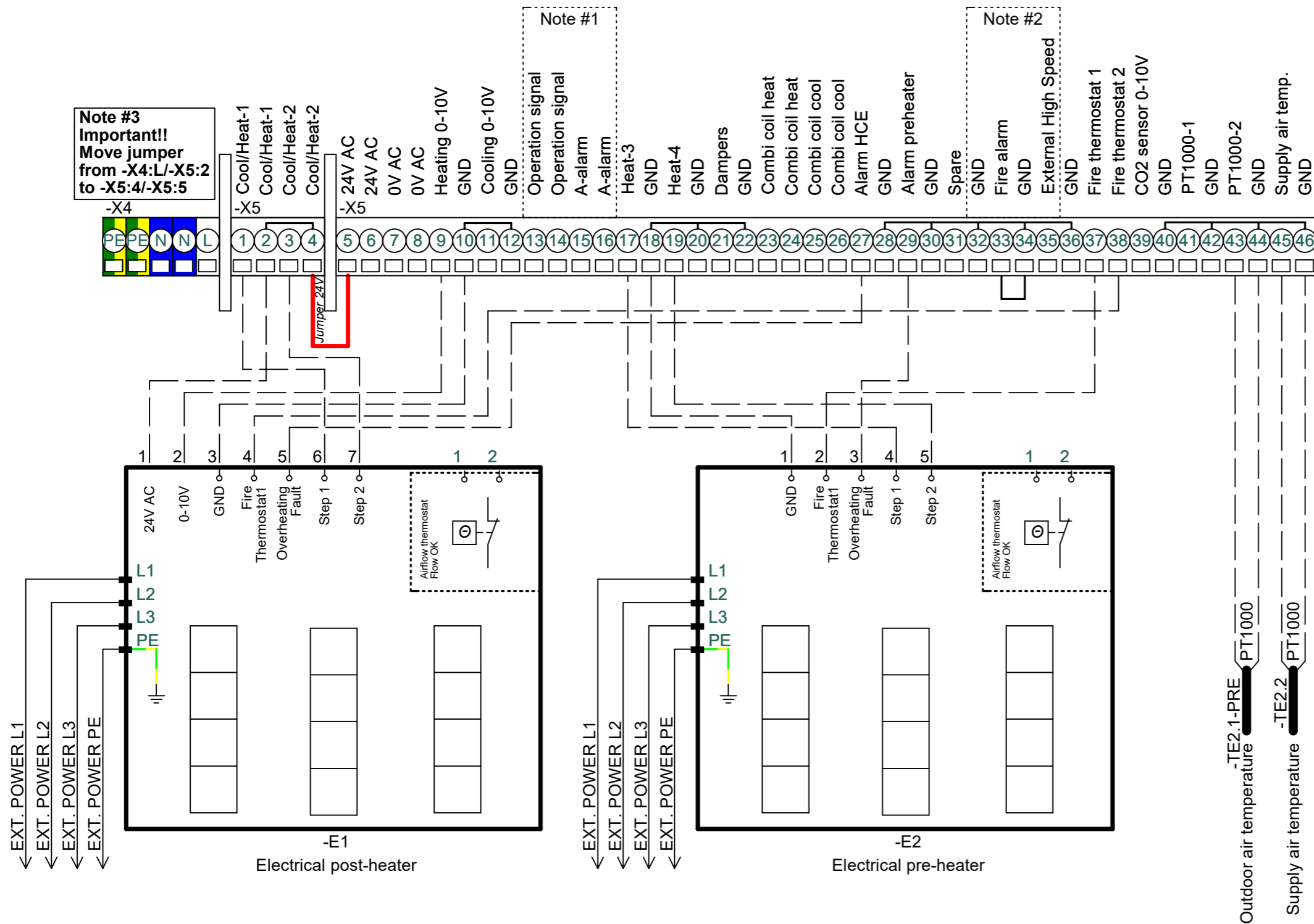

- * Heater Step 2 are only used in the high performance heaters
- * Outdoor air temperature sensor must be mounted in the outside air duct, before the preheating coil.
- * Supply air temperature sensor must be mounted in supply air duct after heating and cooling coils

	Project:	CX3050 & CX3060	Start date:	24-08-2022	Constructor:	DKTSA	Page:	30				
	Drawing number:	0400103	Revision:	D	Page Title:	Configuration 10: Preheater+HCE	Revision date:	08-11-2023	Approved by:	DKLEG	Previous page:	29
							Replaces:	Rev. C	Scale:	1:1	Next page:	31
							EC no.:		Format:		Pages in total:	43

Configuration 11: Preheater + Water Heating Coil + Water Cooling Coil

Continued on page 32

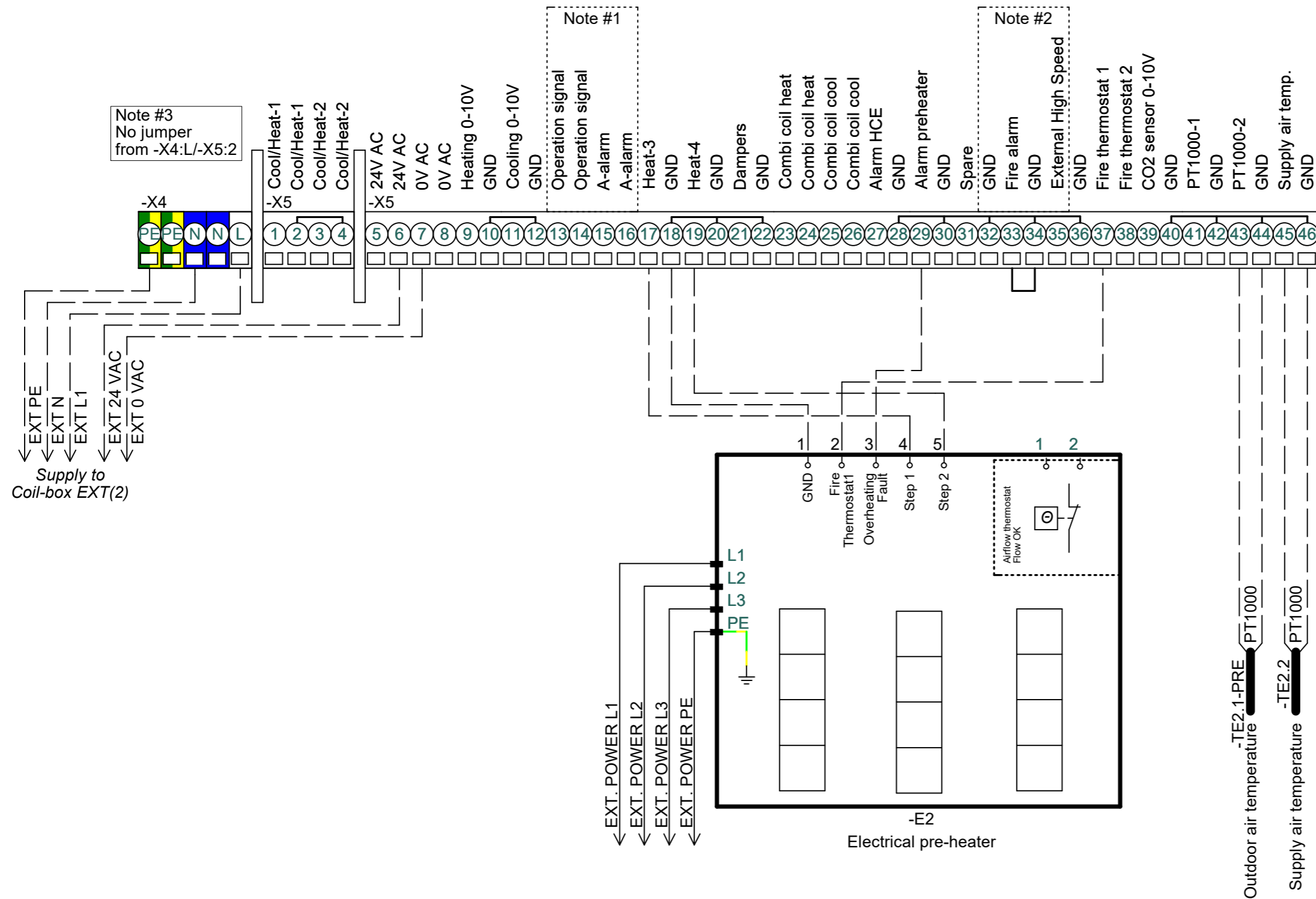

Note #1
Default configuration.
Can be changed to:
- B-alarm output
- Alarm reset
- Summer operation
- Summer night cooling

Note #2
Default configuration.
Can be changed to:
- AHU STOP
- Low speed
- Medium speed
- Frost alarm
- External start
- External reset alarms
If used remove jumper

* Heater Step 2 are only used in the high performance heaters

* Outdoor air temperature sensor must be mounted in the outside air duct, before the preheating coil.

* Supply air temperature sensor must be mounted in supply air duct after heating and cooling coils

* For connecting 3 heating/cooling coils an additional EXT Module is needed. This is addressed with Modbus ID #2. For connecting HCW and CCW please see next page

	Project:	CX3050 & CX3060	Start date:	24-08-2022	Constructor:	DKTSA	Page:	31			
	Drawing number:	0400103	Revision:	D	Page Title:	Configuration 11: Preheater+HCW+CCW	Revision date:	08-11-2023	Approved by:	DKLEG	Previous page:
					Replaces:	Rev. C	Scale:	1:1	Next page:	32	
					EC no.:		Format:		Pages in total:	43	

Configuration 11: Preheater + Water Heating Coil + Water Cooling Coil

Continued from page 31

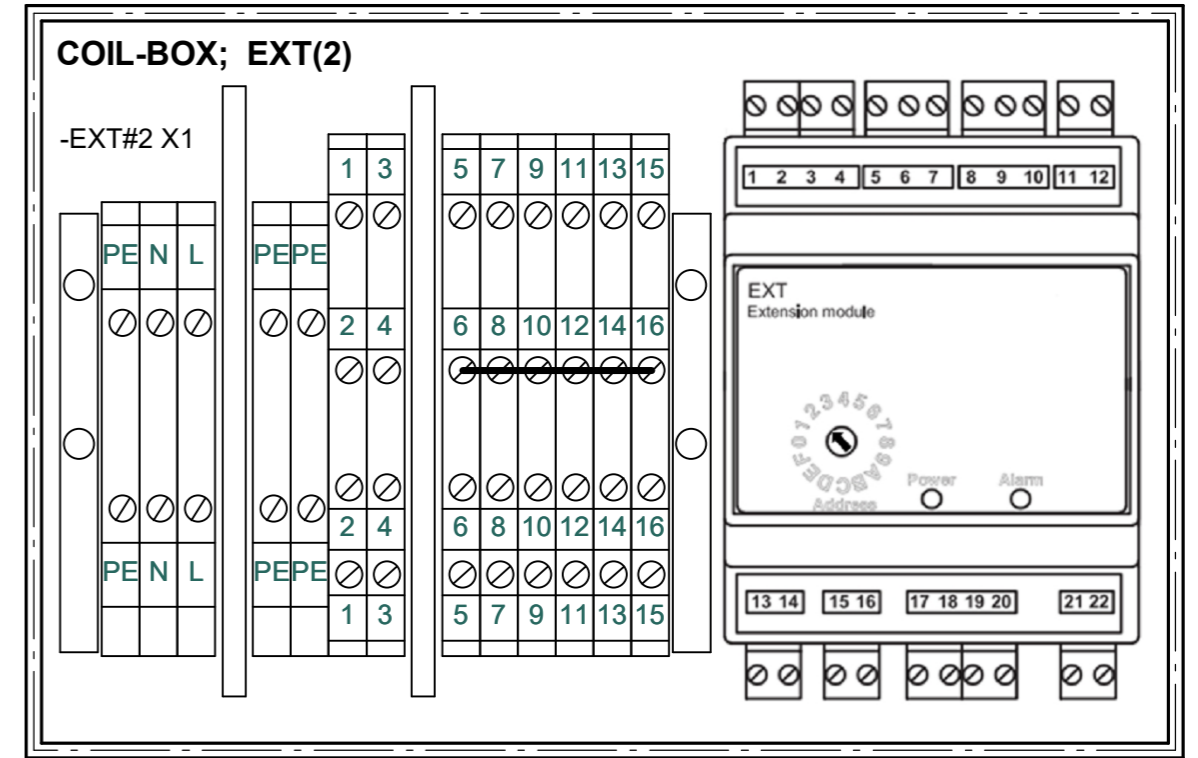
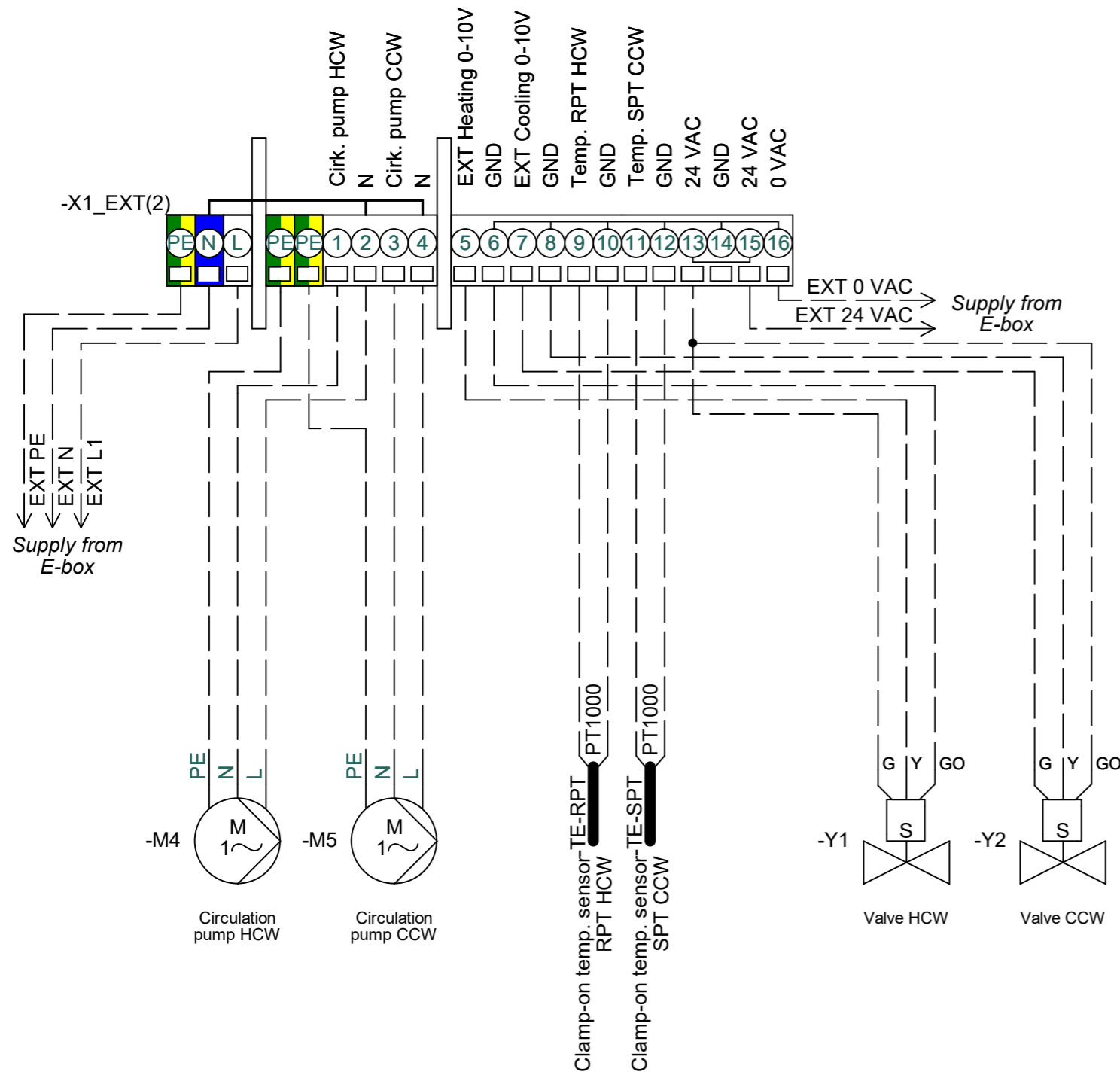

Note #1
Modbus connection to EXcon Master in E-box



Project:
CX3050 & CX3060

Start date:	24-08-2022	Constructor:	DKTSA	Page:	32
Revision date:	08-11-2023	Approved by:	DKLEG	Previous page:	31
Replaces:	Rev. C	Scale:	1:1	Next page:	33
EC no.:		Format:		Pages in total:	43

Drawing number:
0400103

Revision:
D

Page Title:
Configuration 11: Preheater+HCW+CCW

Connections configuration 12: Electric Preheating Coil + Electric Postheating Coil + Water Cooling Coil

Continued on page 34

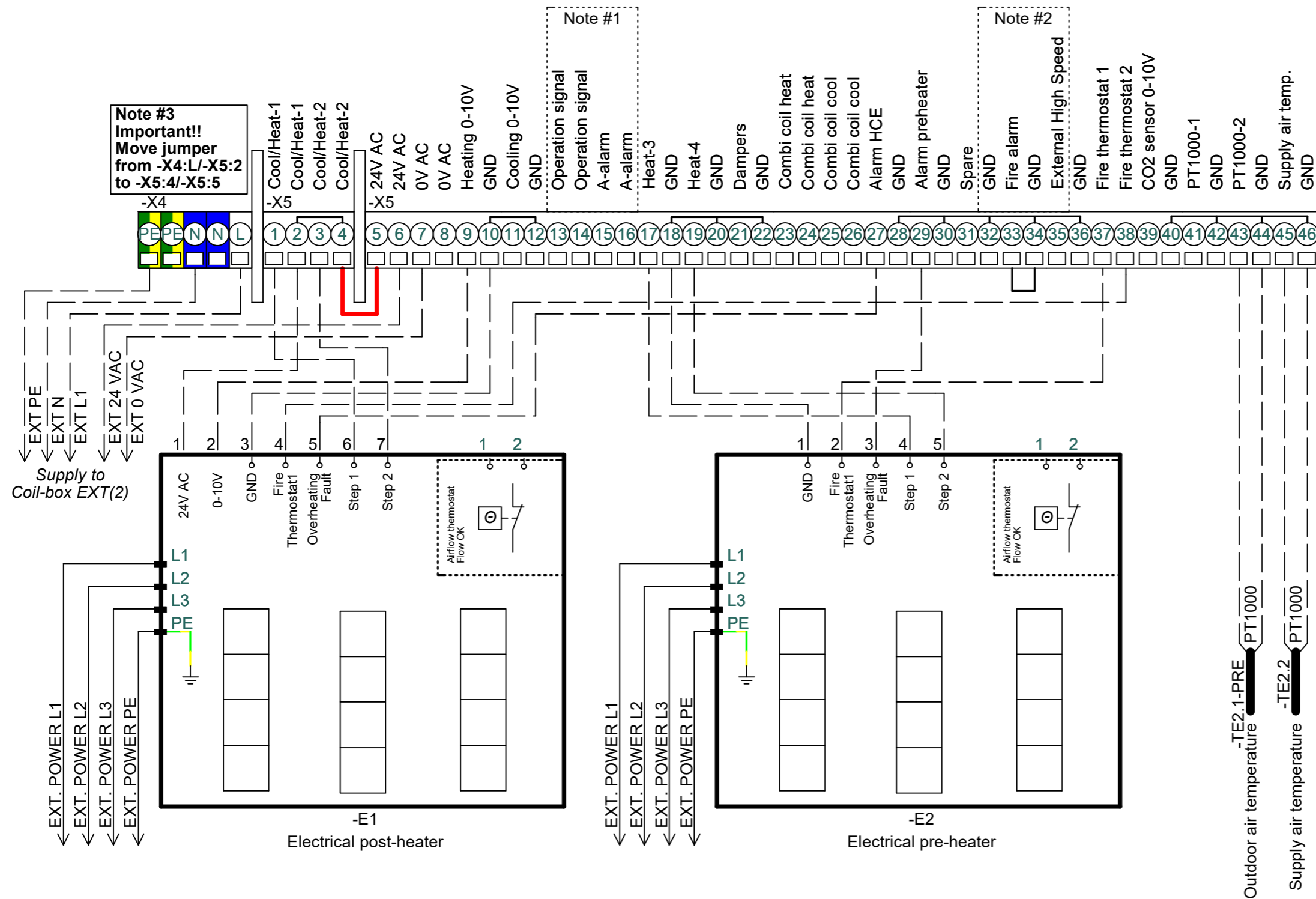

- Note #1**
 Default configuration.
 Can be changed to:
 - B-alarm output
 - Alarm reset
 - Summer operation
 - Summer night cooling
- Note #2**
 Default configuration.
 Can be changed to:
 - AHU STOP
 - Low speed
 - Medium speed
 - Frost alarm
 - External start
 - External reset alarms
- If used remove jumper

- * Heater Step 2 are only used in the high performance heaters
- * Outdoor air temperature sensor must be mounted in the outside air duct, before the preheating coil.
- * Supply air temperature sensor must be mounted in supply air duct after heating and cooling coils
- * For connecting 3 heating/cooling coils an additional EXT Module is needed. This is addressed with Modbus ID #2. For connecting HCW and CCW please see next page

	Project:	CX3050 & CX3060	Start date:	24-08-2022	Constructor:	DKTSA	Page:	33			
	Drawing number:	0400103	Revision:	D	Page Title:	Configuration 12: Preheater+HCE+CCW	Revision date:	08-11-2023	Approved by:	DKLEG	Previous page:
					Replaces:	Rev. C	Scale:	1:1	Next page:	34	
					EC no.:		Format:		Pages in total:	43	

Connections configuration 12: Electric Preheating Coil + Electric Heating Coil + Water Cooling Coil

Continued from page 33

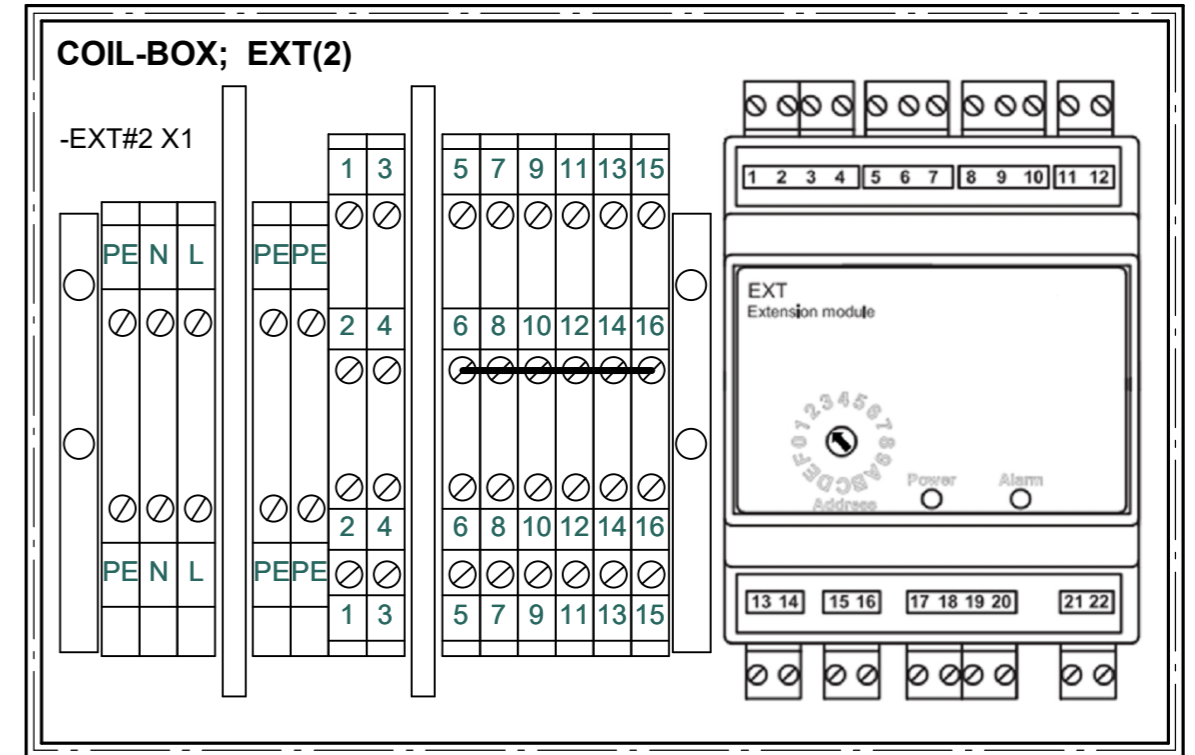
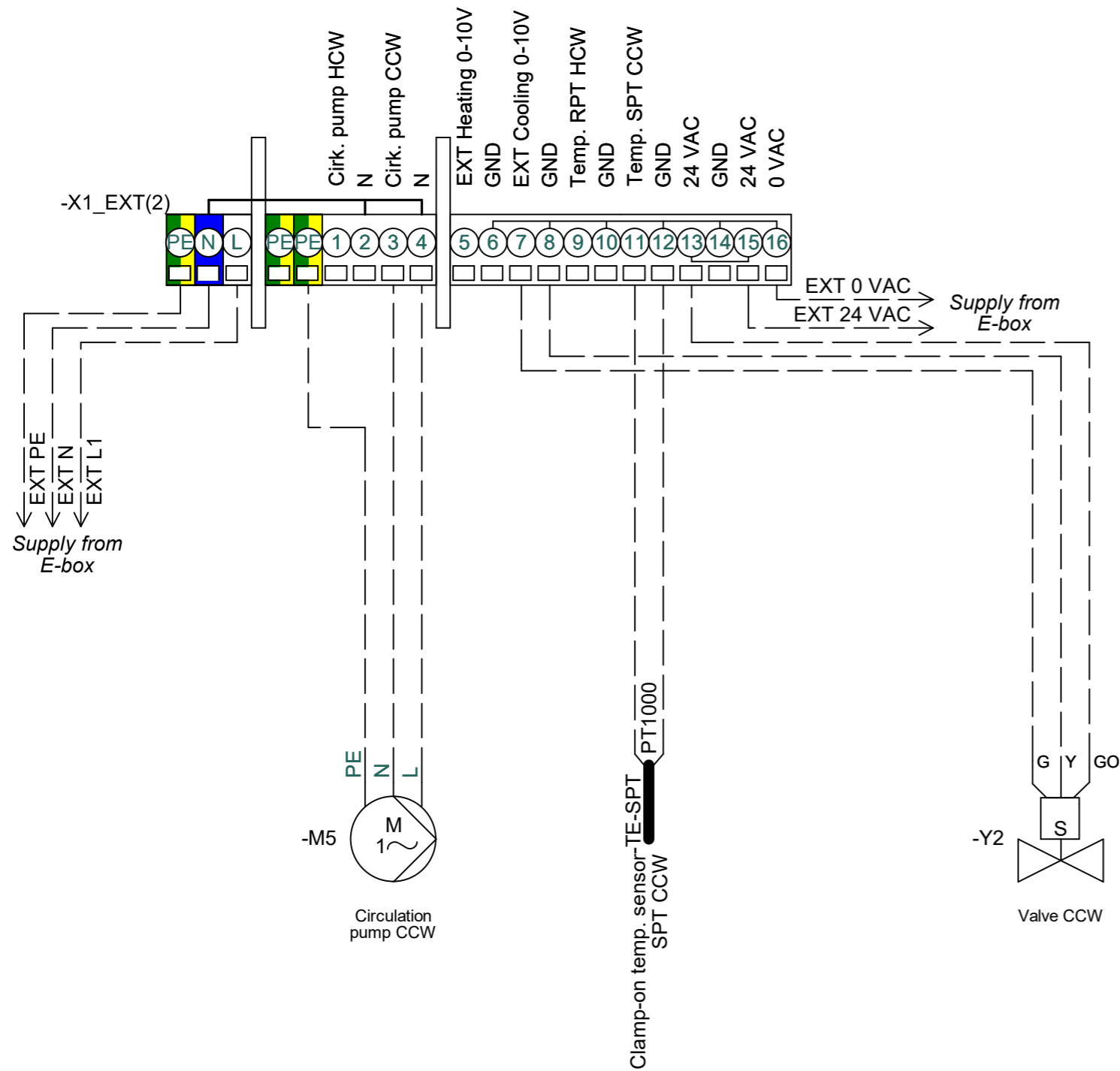

Note #1
Modbus connection to EXcon Master in E-box



Project:
CX3050 & CX3060

Start date:	24-08-2022	Constructor:	DKTSA	Page:	34
Revision date:	08-11-2023	Approved by:	DKLEG	Previous page:	33
Replaces:	Rev. C	Scale:	1:1	Next page:	35
EC no.:		Format:		Pages in total:	43

Drawing number:
0400103

Revision:
D

Page Title:
Configuration 12: Preheater+HCE+CCW

Configuration 13: Change-Over CW (Combi-Coil)

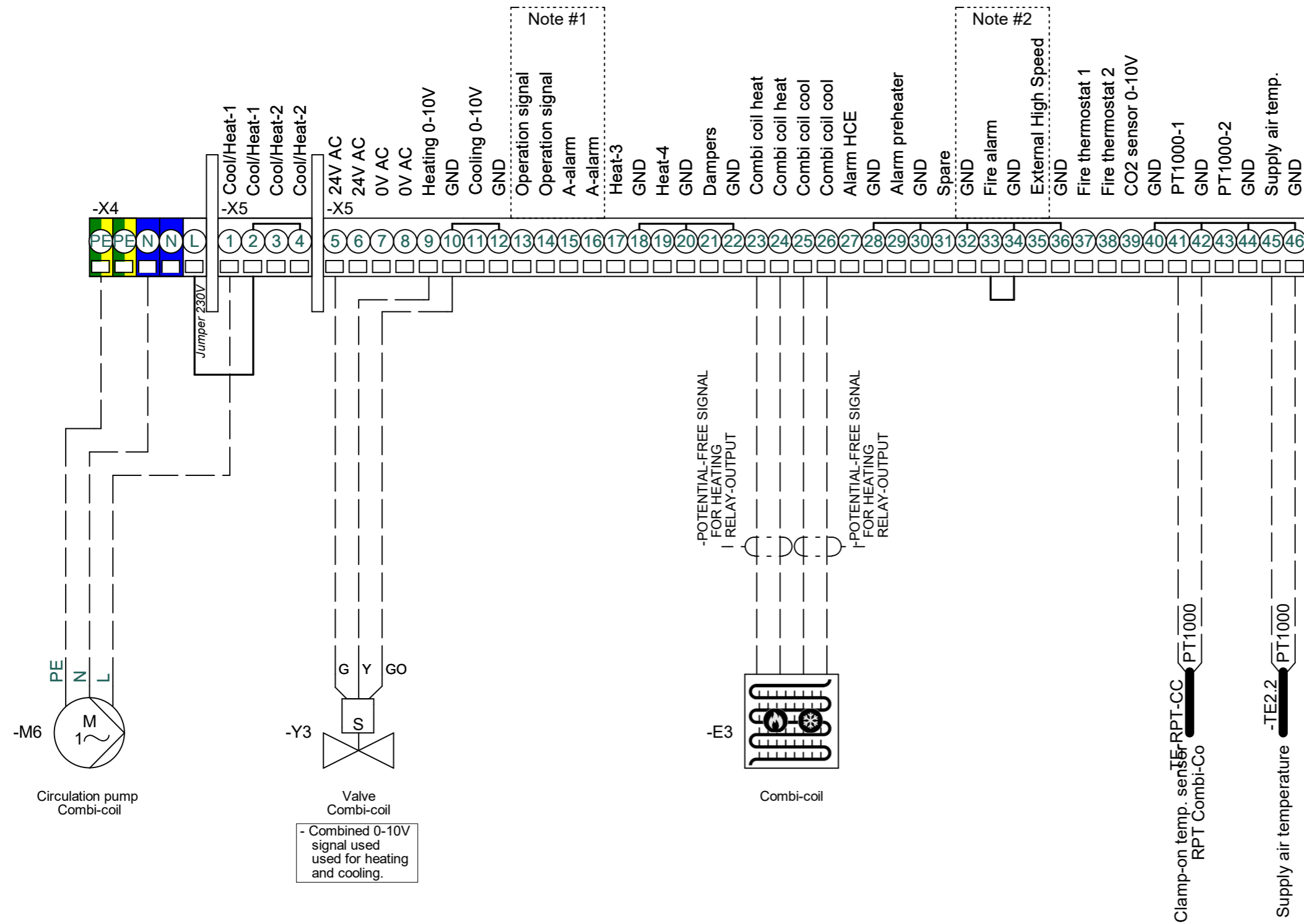

* Supply air temperature sensor must be mounted in supply air duct after heating and cooling coils

	Project:	CX3050 & CX3060	Start date:	24-08-2022	Constructor:	DKTSA	Page:	35			
	Drawing number:	0400103	Revision:	D	Page Title:	Configuration 13: C-O CW (Combi-Coil)	Revision date:	08-11-2023	Approved by:	DKLEG	Previous page:
					Replaces:	Rev. C	Scale:	1:1	Next page:	36	
					EC no.:		Format:		Pages in total:	43	

Connections configuration 14: Preheater + C-O CW (Combi-Coil)

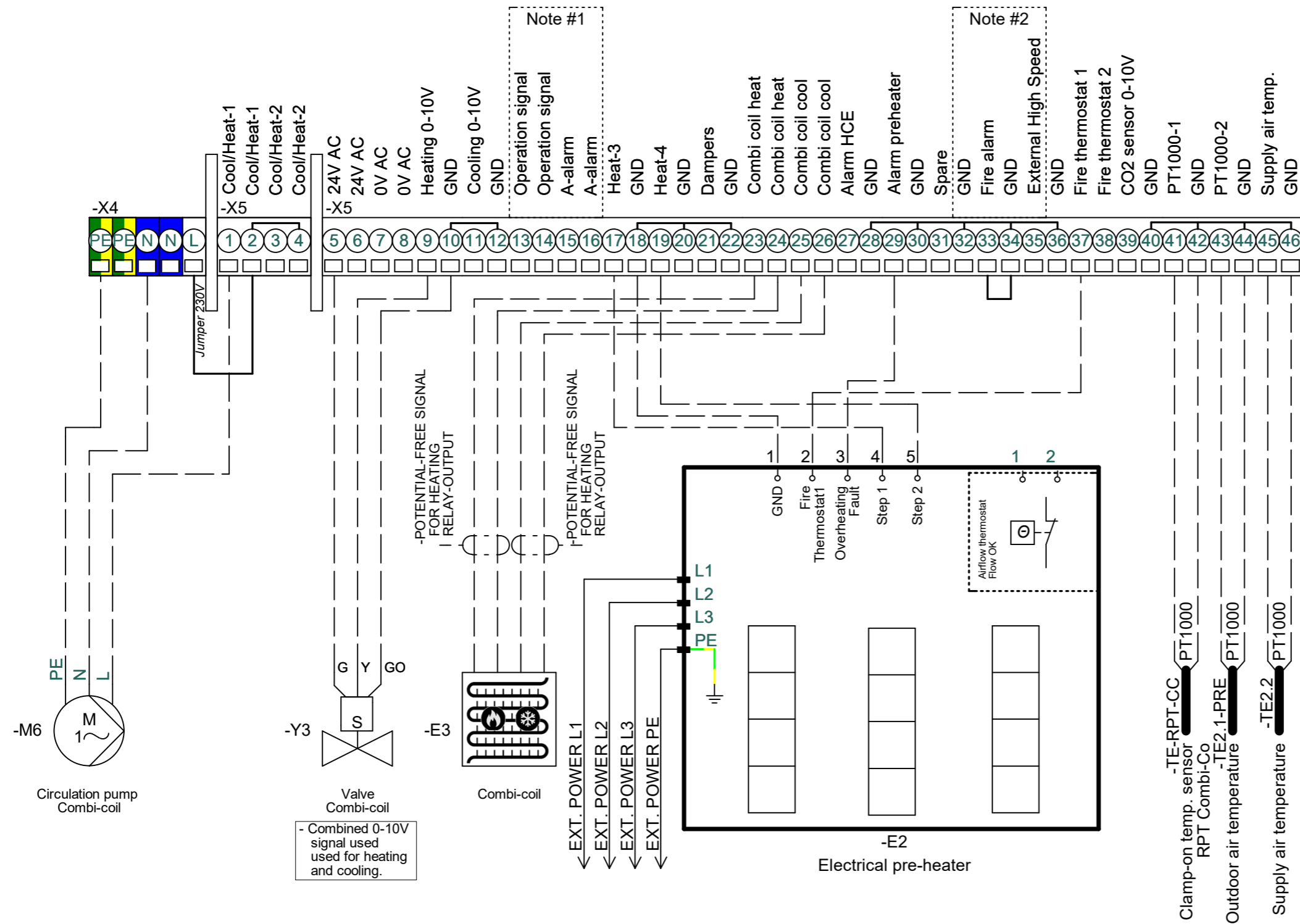

Note #1
 Default configuration.
 Can be changed to:
 - B-alarm output
 - Alarm reset
 - Summer operation
 - Summer night cooling

Note #2
 Default configuration.
 Can be changed to:
 - AHU STOP
 - Low speed
 - Medium speed
 - Frost alarm
 - External start
 - External reset alarms
 If used remove jumper

* Heater Step 2 are only used in the high performance heaters

* Outdoor air temperature sensor must be mounted in the outside air duct, before the preheating coil.

* Supply air temperature sensor must be mounted in supply air duct after heating and cooling coils

	Project:	CX3050 & CX3060	Start date:	24-08-2022	Constructor:	DKTSA	Page:	36	
	Drawing number:	0400103	Revision:	D	Revision date:	08-11-2023	Approved by:	DKLEG	Previous page:
Page Title:		Configuration 14: Preheater+Combi-Coil	Replaces:	Rev. C	Scale:	1:1	Next page:	37	
			EC no.:		Format:		Pages in total:	43	

Optional accessories

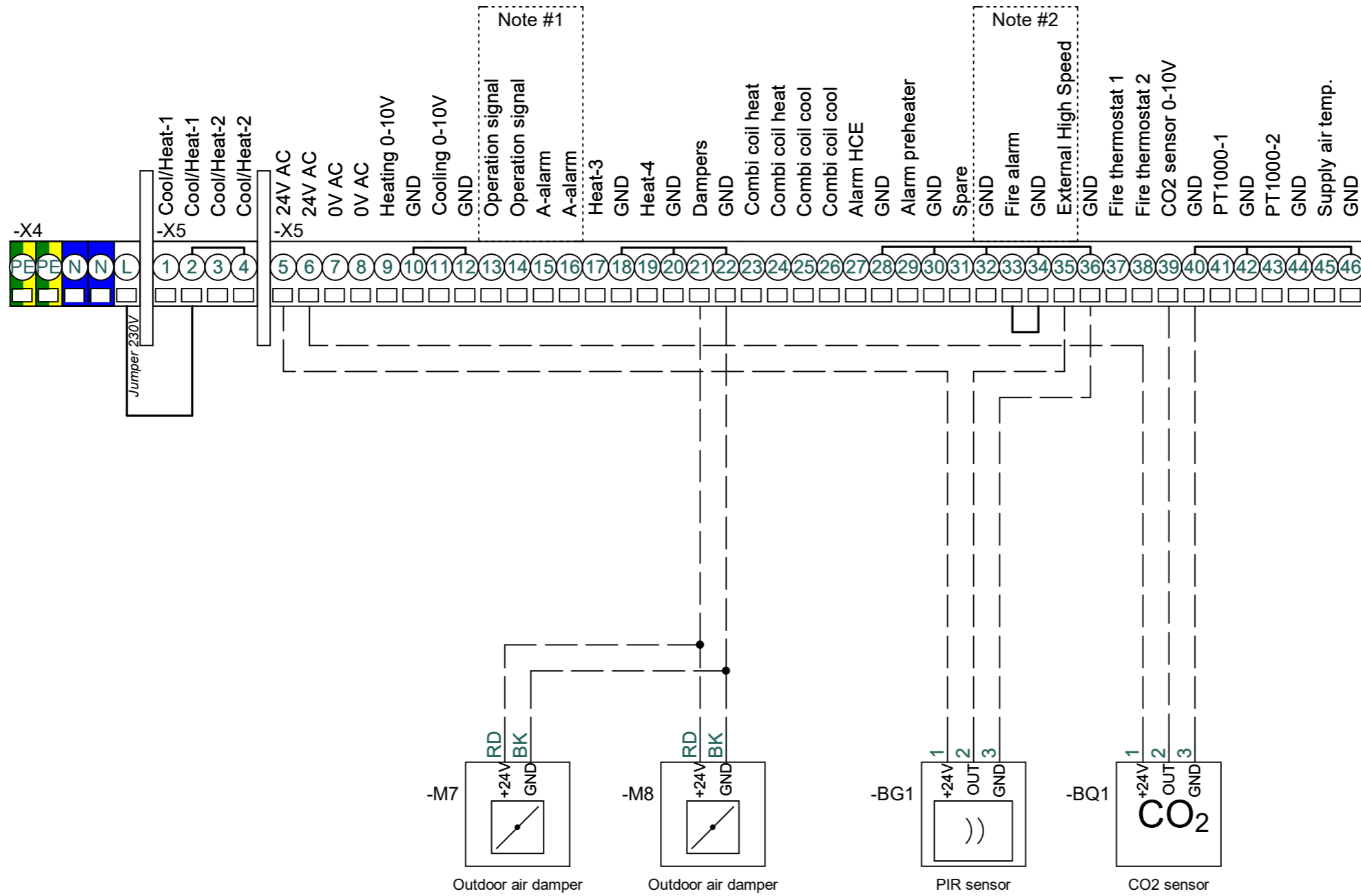

Project:
CX3050 & CX3060

Start date:	24-08-2022	Constructor:	DKTSA	Page:	37
Revision date:	08-11-2023	Approved by:	DKLEG	Previous page:	36
Replaces:	Rev. C	Scale:	1:1	Next page:	38
EC no.:		Format:		Pages in total:	43

Drawing number:
0400103

Revision:
D

Page Title:
Optional accessories

Optional accessories MODBUS

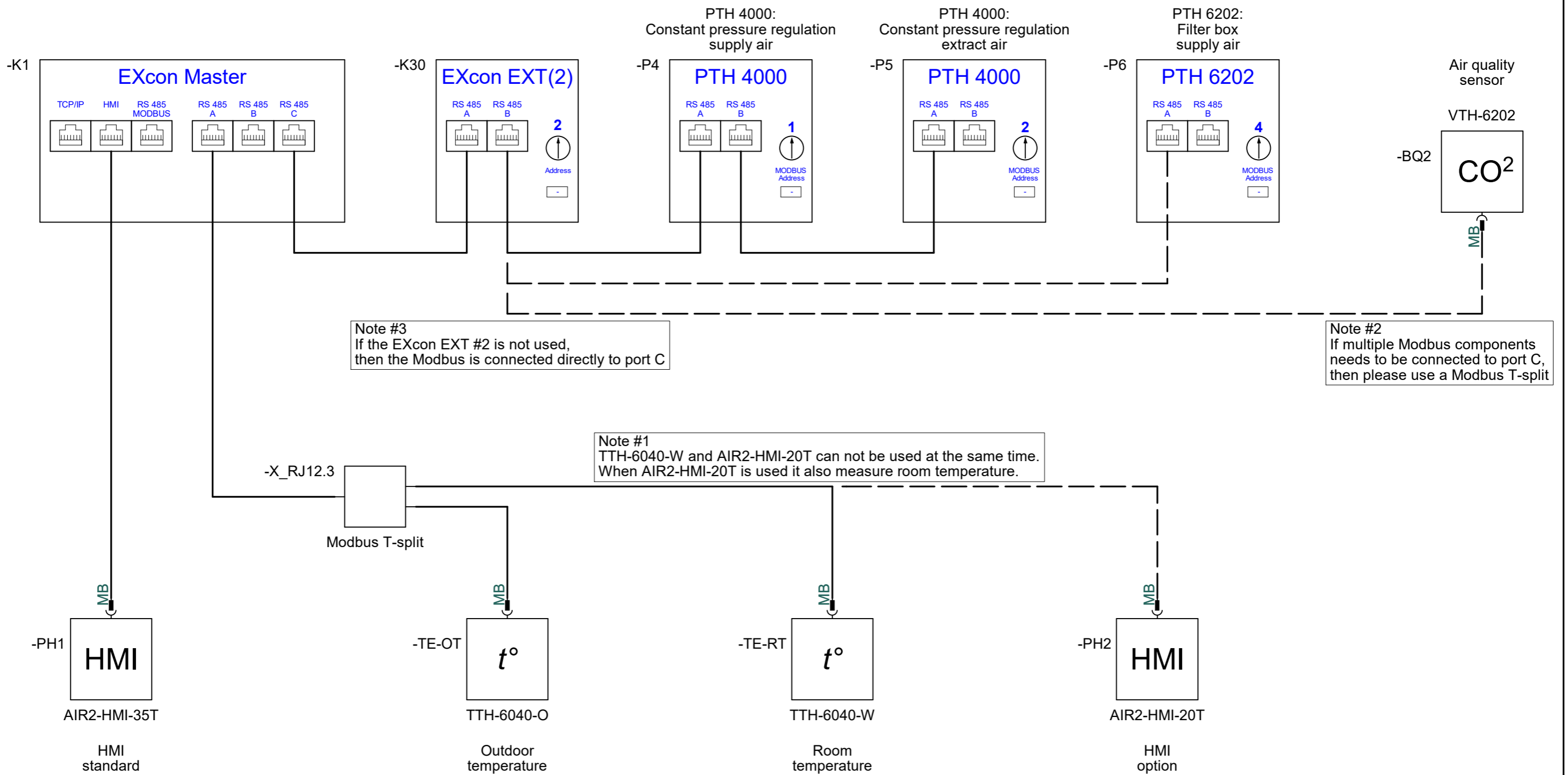

Project:
CX3050 & CX3060

Start date:	24-08-2022	Constructor:	DKTSA	Page:	38
Revision date:	08-11-2023	Approved by:	DKLEG	Previous page:	37
Replaces:	Rev. C	Scale:	1:1	Next page:	40
EC no.:		Format:		Pages in total:	43

Drawing number:
0400103

Revision:
D

Page Title:
Optional accessories MODBUS

Electric heaters

	Project: CX3050 & CX3060	Start date: 24-08-2022	Constructor: DKTSA	Page: 40	
		Revision date: 08-11-2023	Approved by: DKLEG	Previous page: 38	
Drawing number: 0400103	Revision: D	Page Title: Electric heaters	Replaces: Rev. C	Scale: 1:1	Next page: 41
			EC no.:	Format:	Pages in total: 43

Component	Function	Position
+A4.1/-E1	Electric heater Step 1	/43.2
+A4.1/-F1	Main fuse	/43.1
+A4.1/-K1	Contactor HE 1	/43.7
+A4.1/-S2	Main switch pre-heater	/43.1
+A4.1/-T1	Fire thermostat 110°C	/43.5
+A4.1/-T2	Overheating thermostat 70°C	/43.5
+A4.1/-T3	Air flow thermostat Open@60°C/Reset@45°C	/43.8
+A4.1/-W1	Main power supply cable	/43.1
+A4.1/-X1	Terminals for Main supply	/43.1
+A4.1/-X3	Terminals for Control signals	/43.5
+A4.1/-X4	Terminals for Air flow OK	/43.8
+A4.2/-E1	Electric heater Step 1	/44.2
+A4.2/-F1	Main fuse	/44.1
+A4.2/-K1	Contactor HE 1	/44.7
+A4.2/-S3	Main switch heater	/44.1
+A4.2/-T1	Fire thermostat 110°C	/44.5
+A4.2/-T2	Overheating thermostat 70°C	/44.5
+A4.2/-T3	Air flow thermostat Open@60°C/Reset@45°C	/44.8
+A4.2/-TC1	Triac HE 1	/44.4
+A4.2/-W1	Main power supply cable	/44.1
+A4.2/-X1	Terminals for Main supply	/44.1
+A4.2/-X3	Terminals for Control signals	/44.4
+A4.2/-X4	Terminals for Air flow OK	/44.8
+A4.3/-E1	Electric heater Step 1	/45.2
+A4.3/-E2	Electric heater Step 2	/45.3
+A4.3/-F1	Main fuse	/45.1
+A4.3/-K1	Contactor HE 1	/45.7
+A4.3/-K2	Contactor HE 2	/45.8
+A4.3/-S2	Main switch pre-heater	/45.1



Project:
CX3050 & CX3060

Start date: 24-08-2022 Constructor: DKTSA Page: 41

Revision date: 08-11-2023 Approved by: DKLEG Previous page: 40

Drawing number:
0400103

Revision:
D

Page Title:
Electric heaters component overview

Replaces: Rev. C Scale: 1:1 Next page: 42

EC no.: Format: Pages in total: 43

Component	Function	Position
+A4.3/-T1	Fire thermostat 110°C	/45.5
+A4.3/-T2	Overheating thermostat 70°C	/45.5
+A4.3/-T3	Air flow thermostat Open@60°C/Reset@45°C	/45.8
+A4.3/-W1	Main power supply cable	/45.1
+A4.3/-X1	Terminals for Main supply	/45.1
+A4.3/-X3	Terminals for Control signals	/45.5
+A4.3/-X4	Terminals for Air flow OK	/45.8
+A4.4/-E1	Electric heater Step 1	/46.2
+A4.4/-E2	Electric heater Step 2	/46.3
+A4.4/-F1	Main fuse	/46.1
+A4.4/-K1	Contactor HE 1	/46.7
+A4.4/-K2	Contactor HE 2	/46.8
+A4.4/-S3	Main switch heater	/46.1
+A4.4/-T1	Fire thermostat 110°C	/46.5
+A4.4/-T2	Overheating thermostat 70°C	/46.5
+A4.4/-T3	Air flow thermostat Open@60°C/Reset@45°C	/46.8
+A4.4/-TC1	Triac HE 1	/46.4
+A4.4/-W1	Main power supply cable	/46.1
+A4.4/-X1	Terminals for Main supply	/46.1
+A4.4/-X3	Terminals for Control signals	/46.4
+A4.4/-X4	Terminals for Air flow OK	/46.8

	Project: CX3050 & CX3060	Start date: 24-08-2022	Constructor: DKTSA	Page: 42	
		Revision date: 08-11-2023	Approved by: DKLEG	Previous page: 41	
Drawing number: 0400103	Revision: D	Page Title: Electric heaters component overview	Replaces: Rev. C	Scale: 1:1	Next page: 43
			EC no.:	Format:	Pages in total: 43

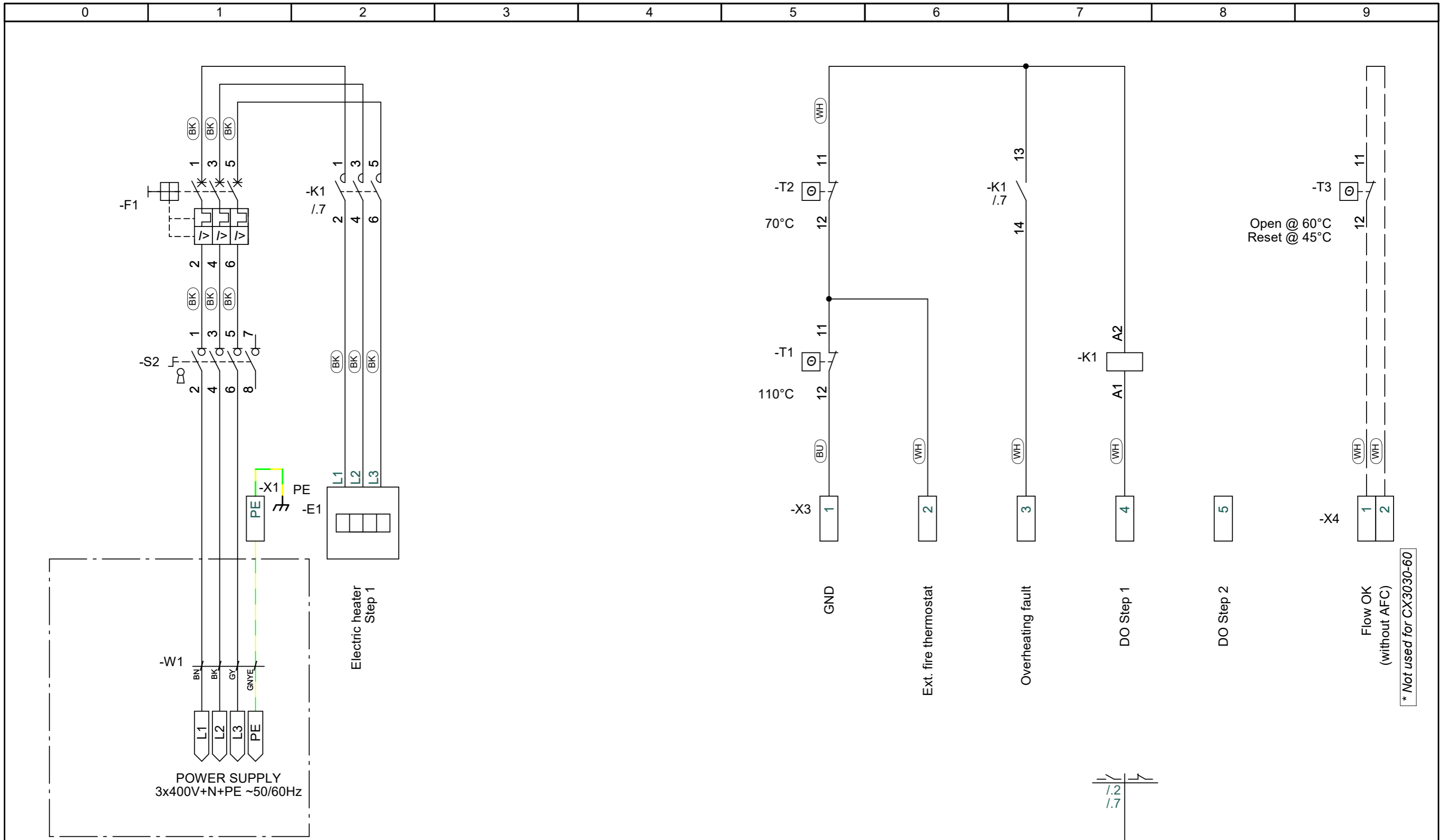

	Project:	CX3050 & CX3060	Start date:	24-08-2022	Constructor:	DKTSA	Page:	43	
	Drawing number:	0400103	Revision date:	08-11-2023	Approved by:	DKLEG	Previous page:	42	
Revision:	D	Page Title:	Electric pre-heater Step 1	Replaces:	Rev. C	Scale:	1:1	Next page:	44
				EC no.:		Format:		Pages in total:	43

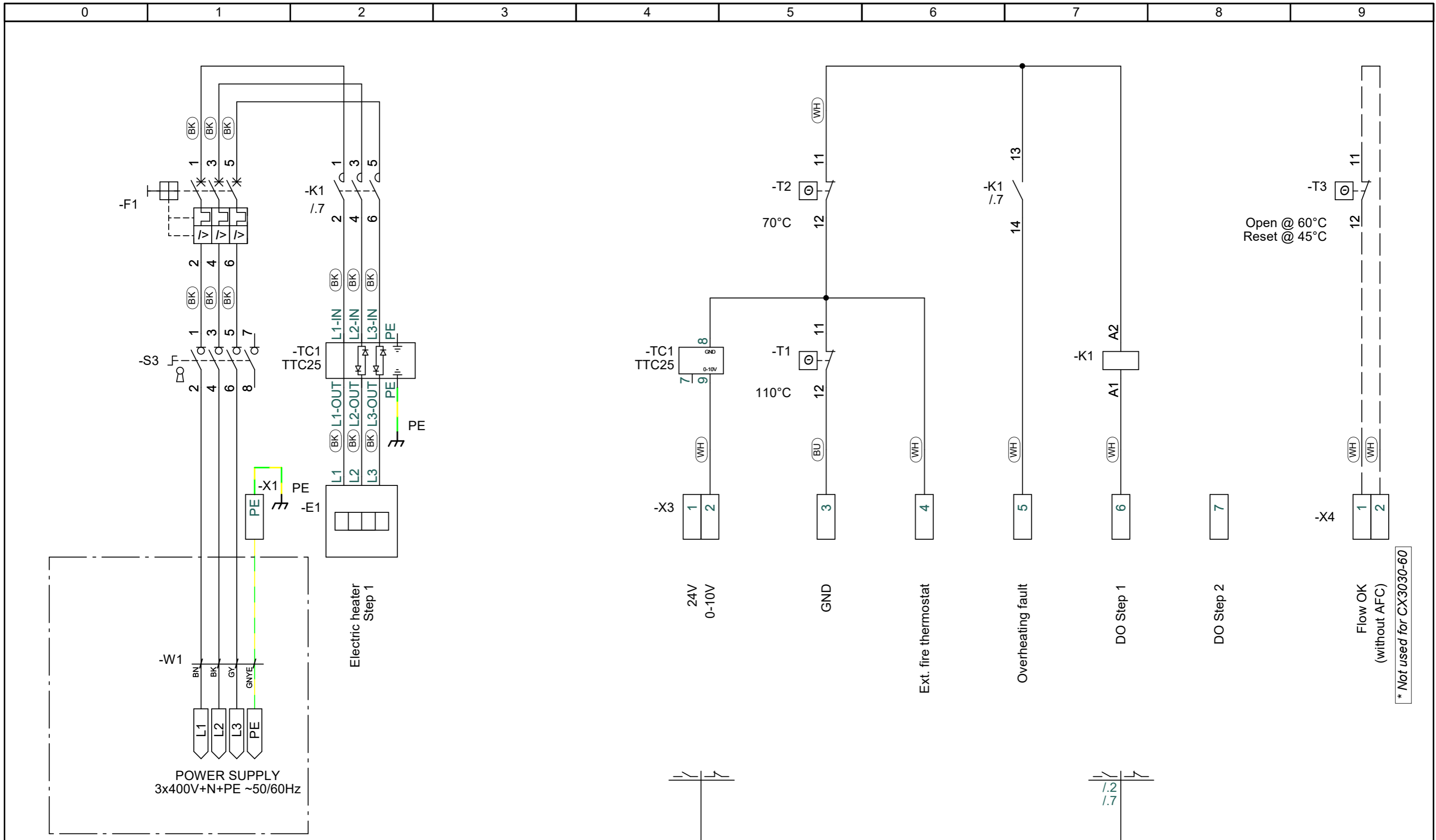

	Project:	CX3050 & CX3060	Start date:	24-08-2022	Constructor:	DKTSA	Page:	44	
	Drawing number:	0400103	Revision date:	08-11-2023	Approved by:	DKLEG	Previous page:	43	
Revision:	D	Page Title:	Electric heater Step 1	Replaces:	Rev. C	Scale:	1:1	Next page:	45
				EC no.:		Format:		Pages in total:	43

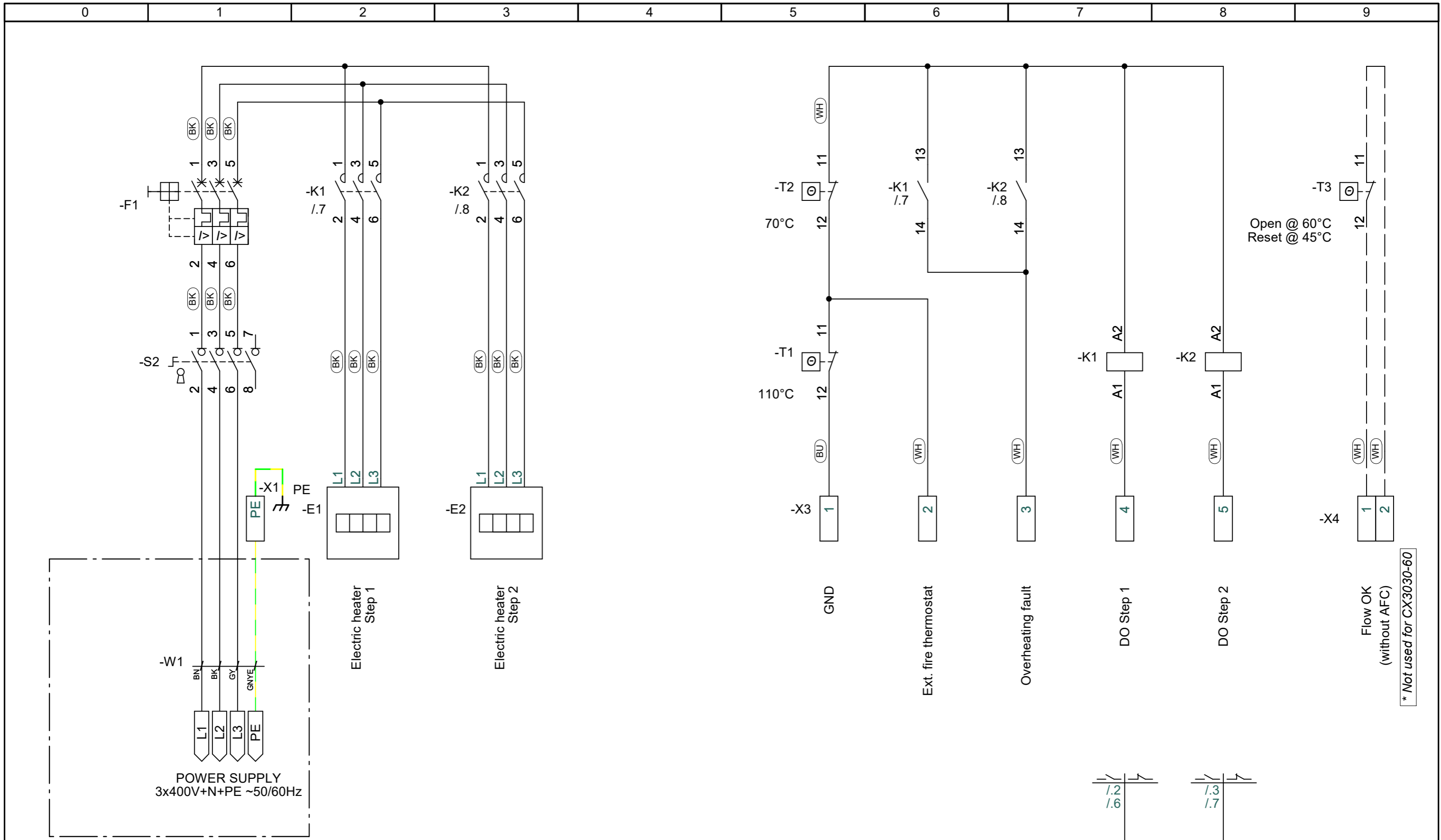

	Project:	CX3050 & CX3060		Start date:	24-08-2022	Constructor:	DKTSA	Page:	45
	Drawing number:	Revision:	Page Title:	Replaces:	Rev. C	Scale:	1:1	Next page:	46
0400103	D	Electric pre-heater Step 1 & 2		EC no.:		Format:		Pages in total:	43

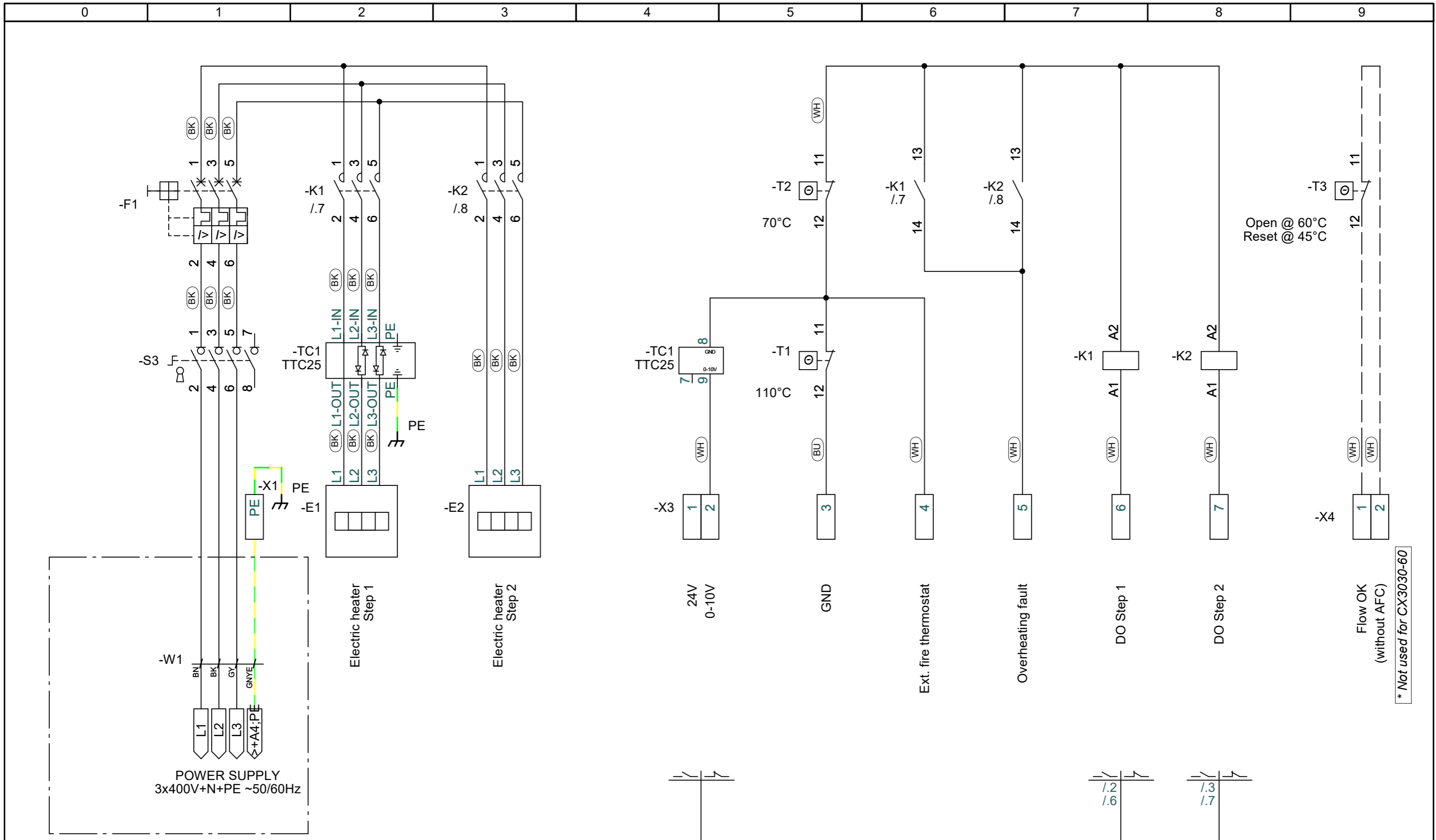

	Project:	CX3050 & CX3060	Start date:	24-08-2022	Constructor:	DKTSA	Page:	46	
	Drawing number:	0400103	Revision date:	08-11-2023	Approved by:	DKLEG	Previous page:	45	
Revision:	D	Page Title:	Electric heater Step 1 & 2	Replaces:	Rev. C	Scale:	1:1	Next page:	47
				EC no.:		Format:		Pages in total:	43

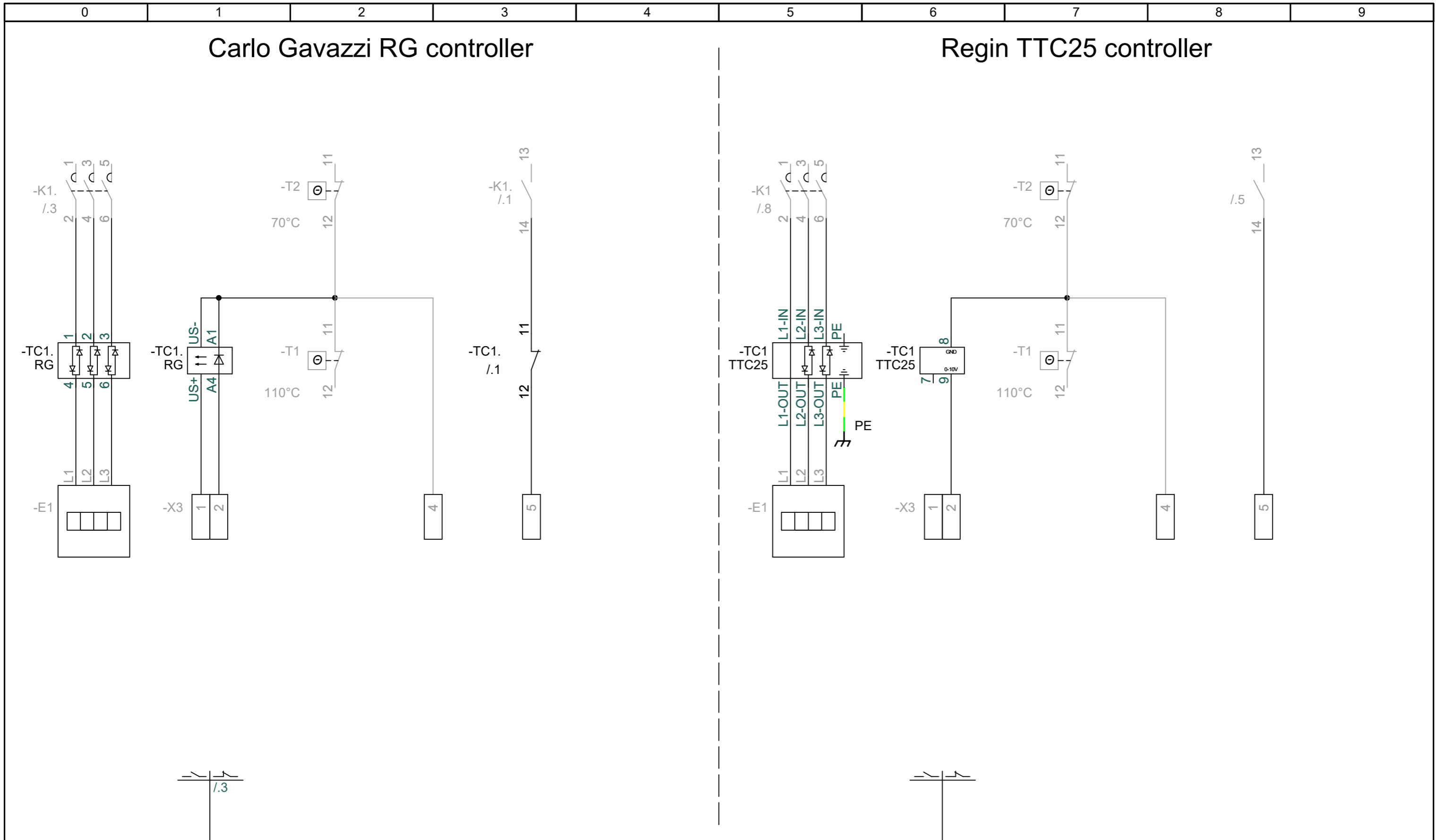

	Project:	Start date:	24-08-2022	Constructor:	DKTSA	Page:	47
	CX3050 & CX3060	Revision date:	08-11-2023	Approved by:	DKLEG	Previous page:	46
Drawing number:	Revision:	Page Title:	Replaces:	Rev. C	Scale:	1:1	Next page:
0400103	D	Carlo Gavazzi RG vs Regin TTC25	EC no.:		Format:		Pages in total:
							43