

EasyHOME Auto / PureAIR Classic

- FR Notice d'installation et de maintenance
- EN Installation and maintenance instructions
- DE Installations- und Wartungsanleitung

- NL Montage- en onderhoudshandleiding
- ES Instrucción de instalación y de mantenimiento
- IT Manuale di installazione e di manutenzione



EasyHOME
Auto



EasyHOME
PureAIR

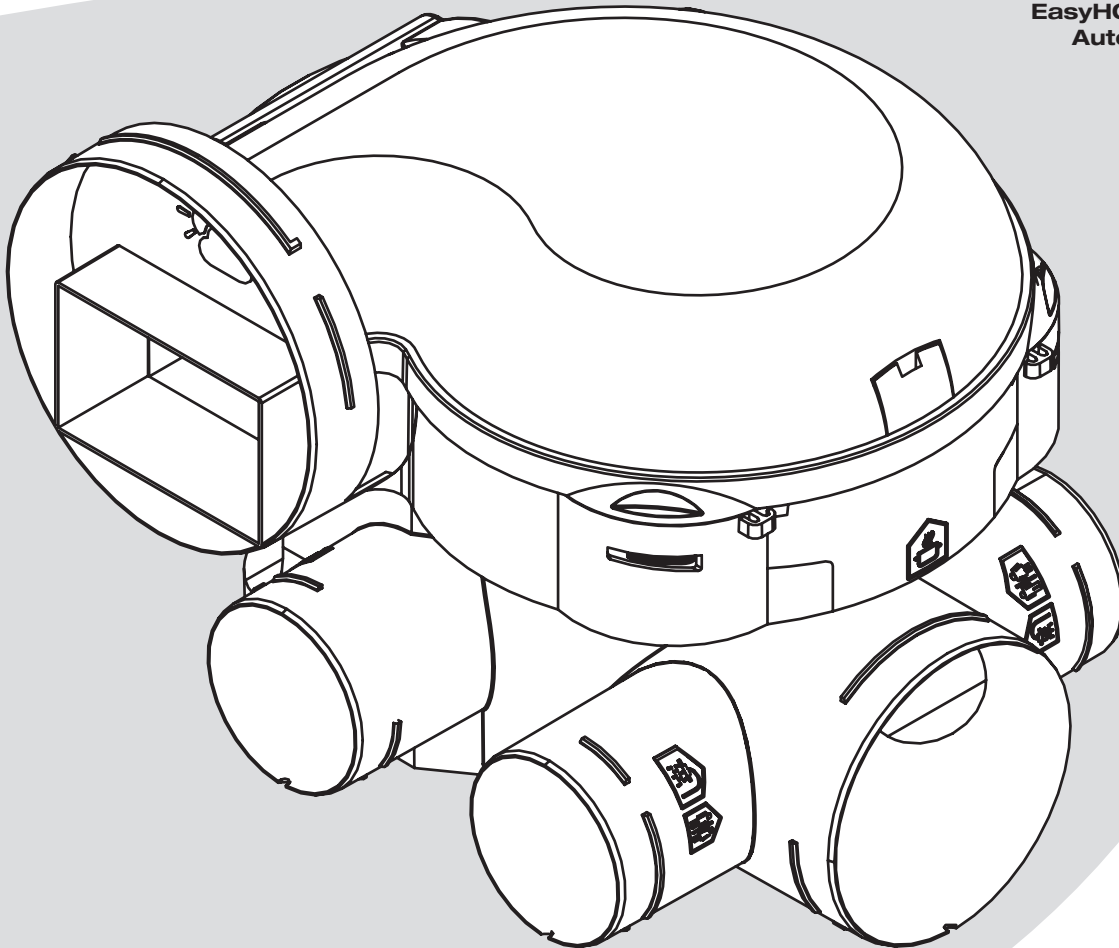

 **aldes**

1.1. Description • Description • Beschreibung • Omschrijving • Descripción • Descrizione

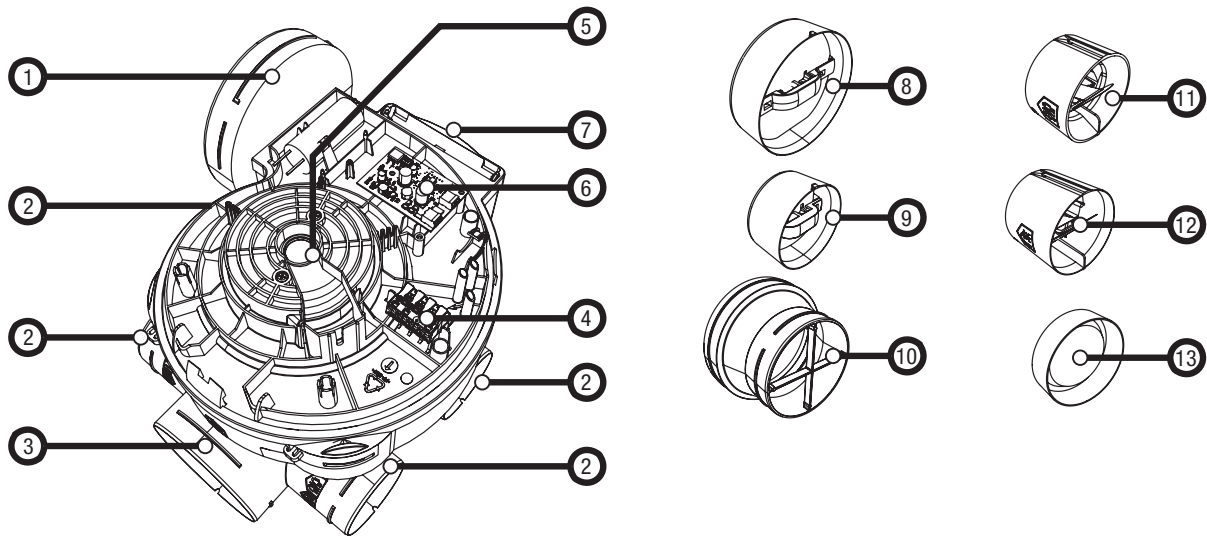

	FR	EN	DE	NL	ES	IT
1	Piquage refoulement extérieur	Outdoor discharge connection	Messanschluss Abluft	Aftakking buitenafvoer	Orificio de descarga exterior	Presca scarico esterno
2	Piquage sdb/wc	Bath/WC connection	Messanschluss BZ/WC	Aftakking badkamer/toilet	Orificio cuarto de baño/WC	Presca bagno
3	Piquage cuisine	Kitchen connection	Messanschluss Küche	Aftakking keuken	Orificio cocina	Presca cucina
4	Bornier électrique	Electric terminal block	Elektroklemmleiste	Aansluitklem	Bornes electricidad	Morsettiere elettrica
5	Motoventilateur	Motorised fan unit	Motorgebläse	Motorventilator	Motoventilador	Motoventilatore
6	Carte électronique	PCB	Elektronikkarte	Printplaat	Tarjeta electrónica	Scheda elettronica
7	Zone de fixation paroi	Wall attachment area	Wandbefestigungsbereich	Muurbevestigingsgebied	Zona de fijación en pared	Zona fissaggio parete
8	Autoamplic EasyHOME cuisine	EasyHOME kitchen self-amplifier	EasyHOME Selbstverstärker Küche	Autoamplic EasyHOME keuken	Autoamplificador EasyHOME cocina	Autoamplificatore EasyHOME cucina
9	Autoamplic EasyHOME sdb	EasyHOME bath self-amplifier	EasyHOME Selbstverstärker BZ	Autoamplic EasyHOME badkamer	Autoamplificador EasyHOME cuarto de baño	Autoamplificatore EasyHOME bagno
10	Raccord refoulement Ø160/125	Discharge connector Ø160/125	Ausblasanschluss Ø160/125	Uitblaasaansluiting Ø160/125	Conexión de descarga Ø160/125	Raccordo scarico Ø160/125
11	Régulateur sdb	Bath controller	BZ-Regler	Regelaar badkamer	Regulador cuarto de baño	Regolatore bagno
12	Régulateur wc	WC controller	WC-Regler	Regelaar toilet	Regulador WC	Regolatore bagno
13	Bouchon piquage	Connection plug	Messanschlusskappe	Afsluitdop aftakking	Tapón de orificio	Tappo presa

	GPE EasyHOME Auto	Kit EasyHOME Auto	Kit EasyHOME Auto + ColorLINE®	GPE EasyHOME PureAIR CLASSIC	Kit EasyHOME PureAIR CLASSIC
N°	11026031	11026032 - 11035403	11026033 - 11035409	11033055	11033056
1	1	1	1	1	1
2	4	4	4	4	4
3	1	1	1	1	1
4	1	1	1	1	1
5	1	1	1	1	1
6				1	1
7	1	1	1	1	1
8	1	1	1	1	1
9				2	2
10	1	1	1	1	1
11	1	1	2		
12	1	1	2	2	2
13	2	2	2	2	2

1.2. Dimensions • Dimensions • Abmessungen • Afmetingen • Dimensiones • Dimensioni (mm)

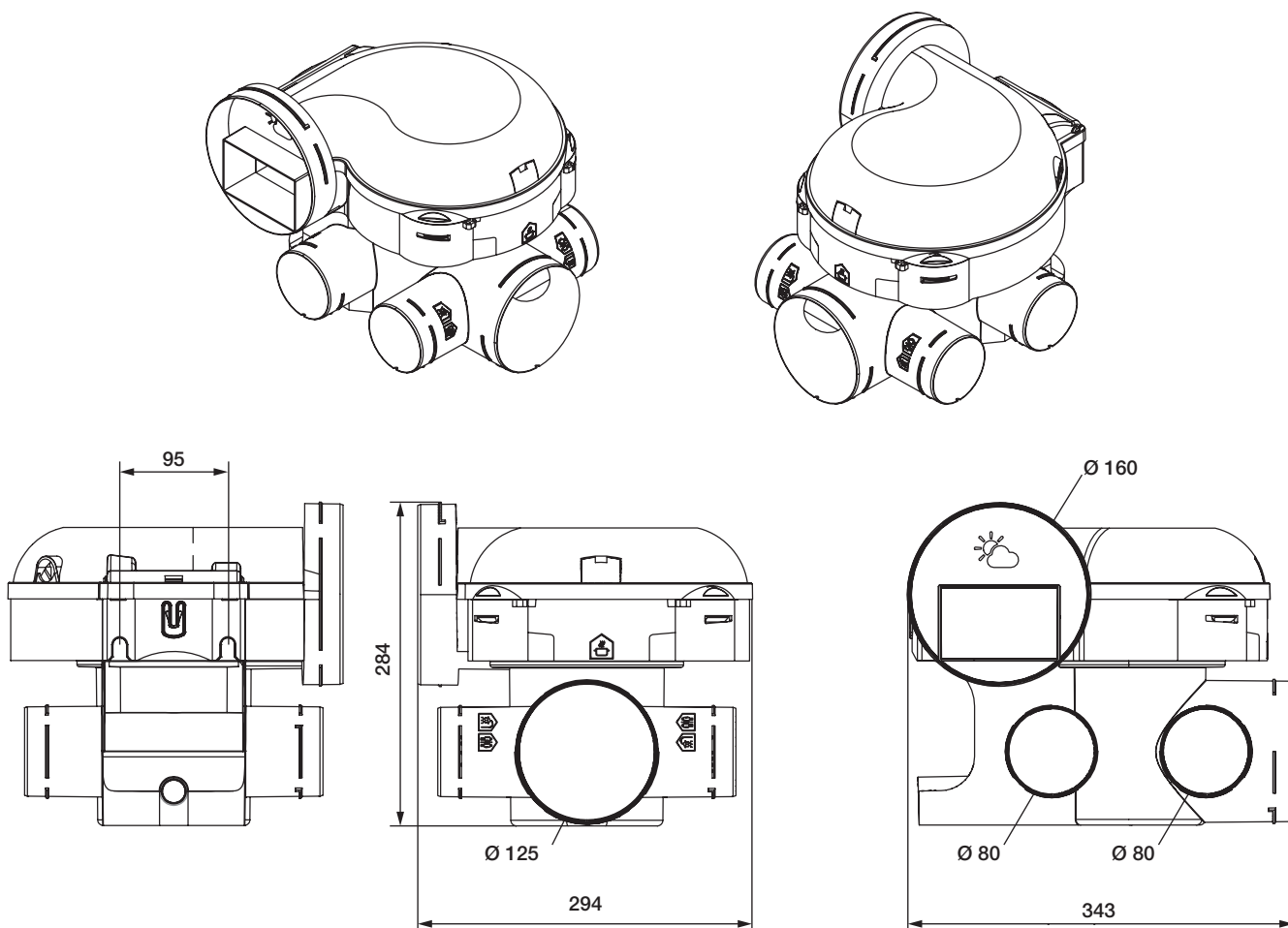

1.3. Recommendations • Recommendations • Empfehlungen • Aanbevelingen • Recomendacions • Raccomandazioni

- FR** Avant installation, mise en route et maintenance, lire attentivement la fiche «Mise en garde et informations réglementaires», jointe à ce produit. Ce produit doit être installé hors de portée des enfants.

.....
- EN** Before installing, activating and maintaining this product, please read the «Precautions and regulatory information» data sheet provided. This product must be installed out of the reach of children.

.....
- DE** Lesen Sie das Produkt-Beilageblatt mit den „Warnhinweisen und verordnungsrechtlichen Informationen“ bitte vor der Installation, Inbetriebnahme und Instandhaltung sorgfältig durch. Dieses Produkt sollte außerhalb der Reichweite von Kindern aufgestellt werden.

.....
- NL** Voor installatie, inbedrijfstelling en onderhoud eerst het document 'Waarschuwingen en reglementaire informatie' lezen dat bij dit product is bijgeleverd. Dit product moet buiten het bereik van kinderen worden geïnstalleerd.

.....
- ES** Antes de la instalación, la puesta en marcha y el mantenimiento, lea detenidamente la ficha «Advertencia e informaciones reglamentarias» adjunta a este producto. Este producto debe instalarse fuera del alcance de los niños.

.....
- IT** Prima delle operazioni di installazione, avviamento e manutenzione, leggere attentamente la scheda « Avvertenze e informazioni regolamentari » allegata al prodotto. Questo prodotto deve essere installato fuori dalla portata dei bambini.

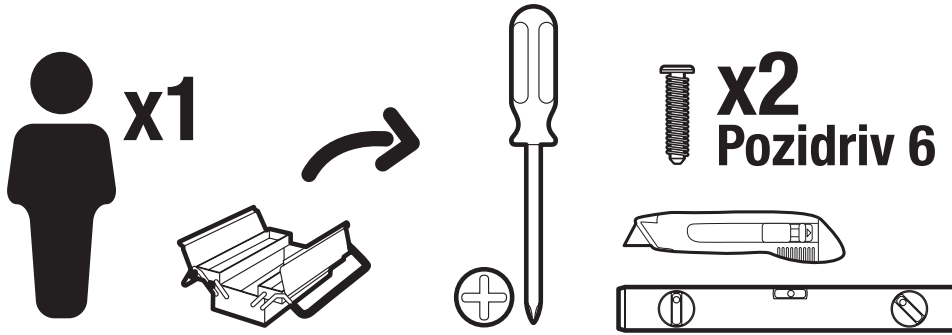

2.1. Recommendations • Recommendations • Empfehlungen • Aanbevelingen •
 Recomendaciones • Raccomandazioni

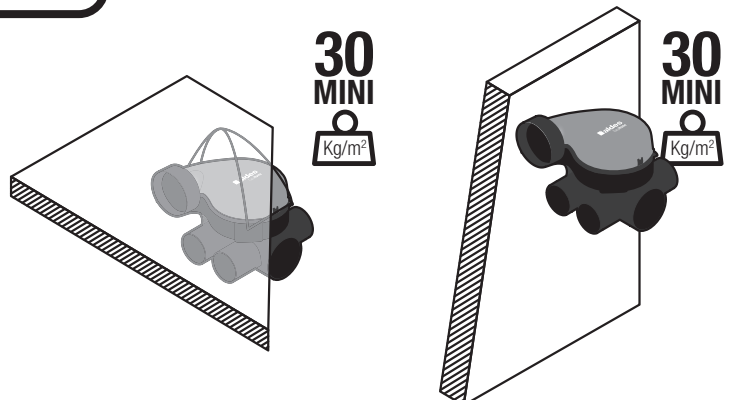
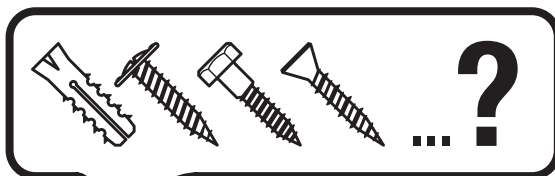
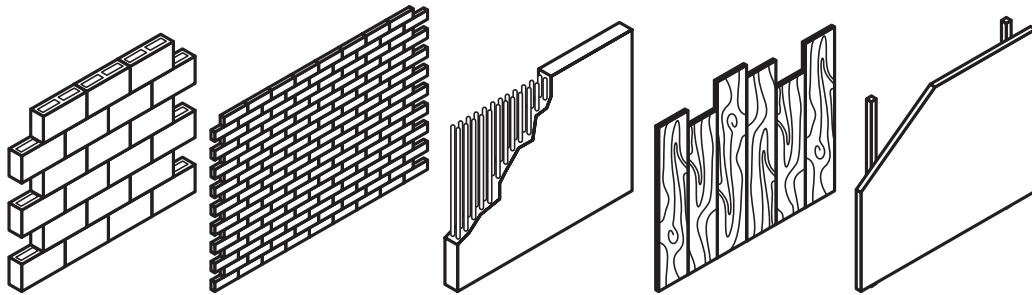
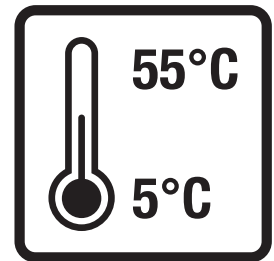
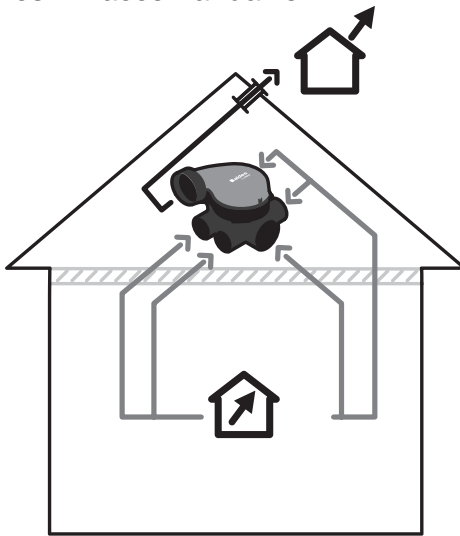

2.2. Plans d'implantation • Installation plans • Einbaupläne • Montageschema's • Planes de implantación • Disegni di montaggio

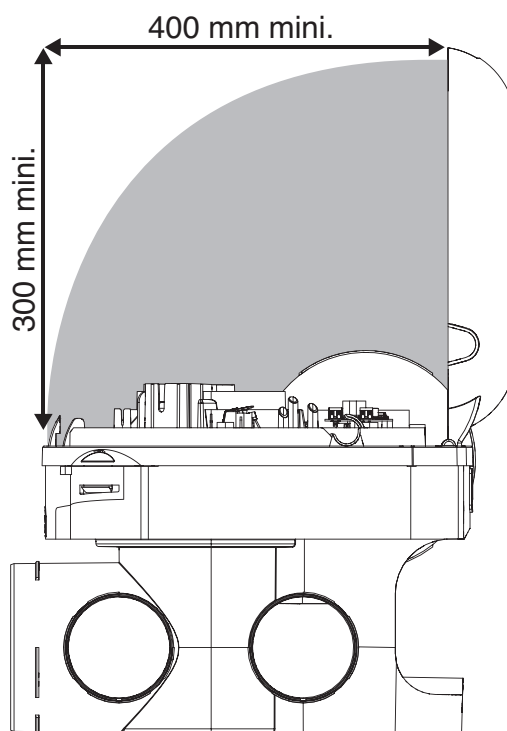
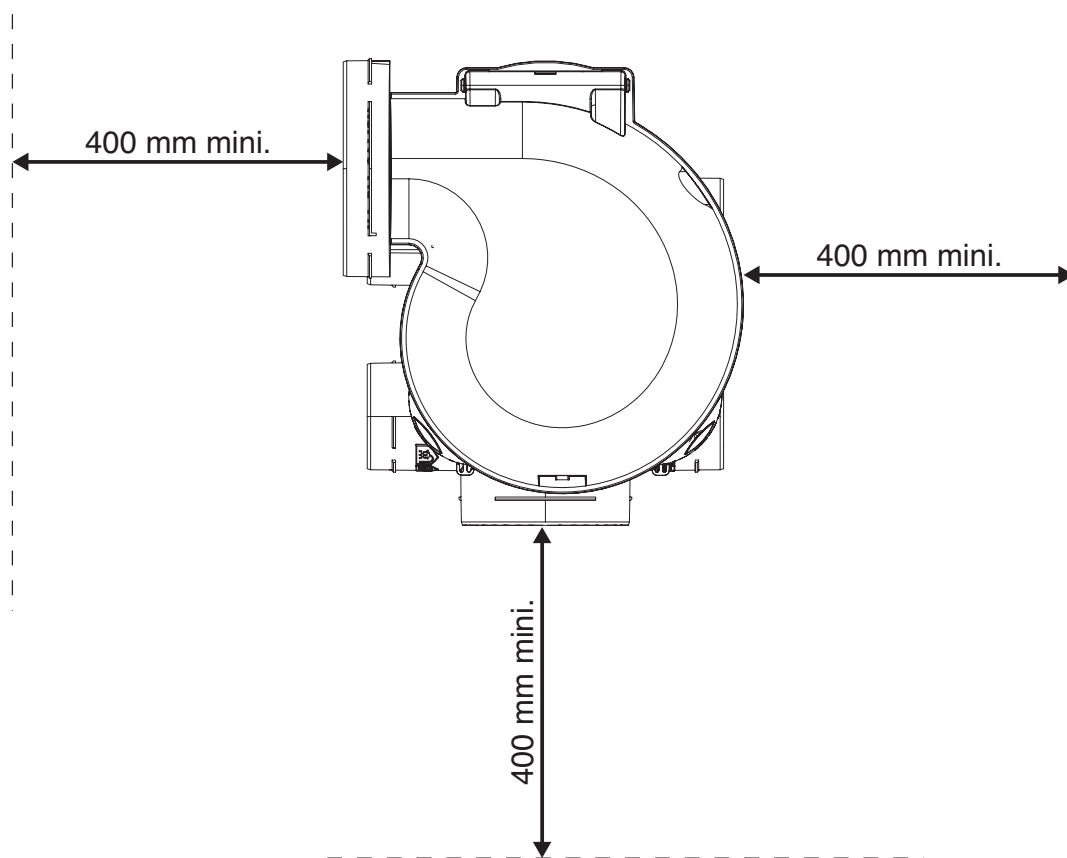

2.3. Montage suspendu • Suspended attachment • Hängende Montage • Hangende montage •
Montaje suspendido • Montaggio a soffitto

30
MINI
Kg/m²

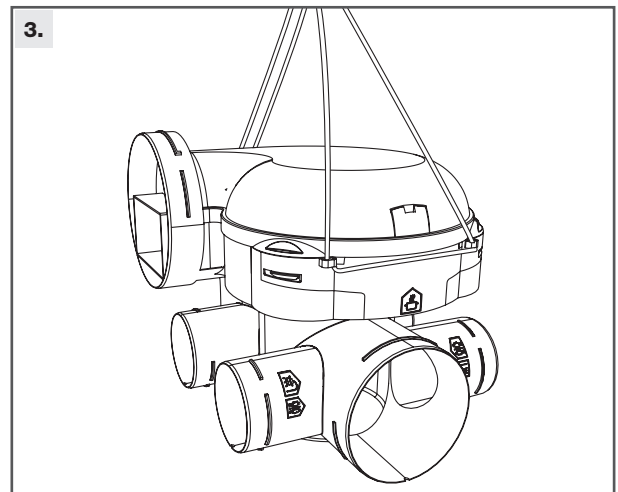
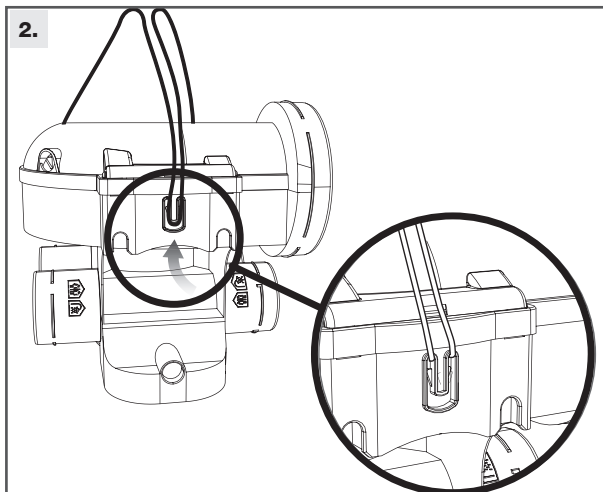
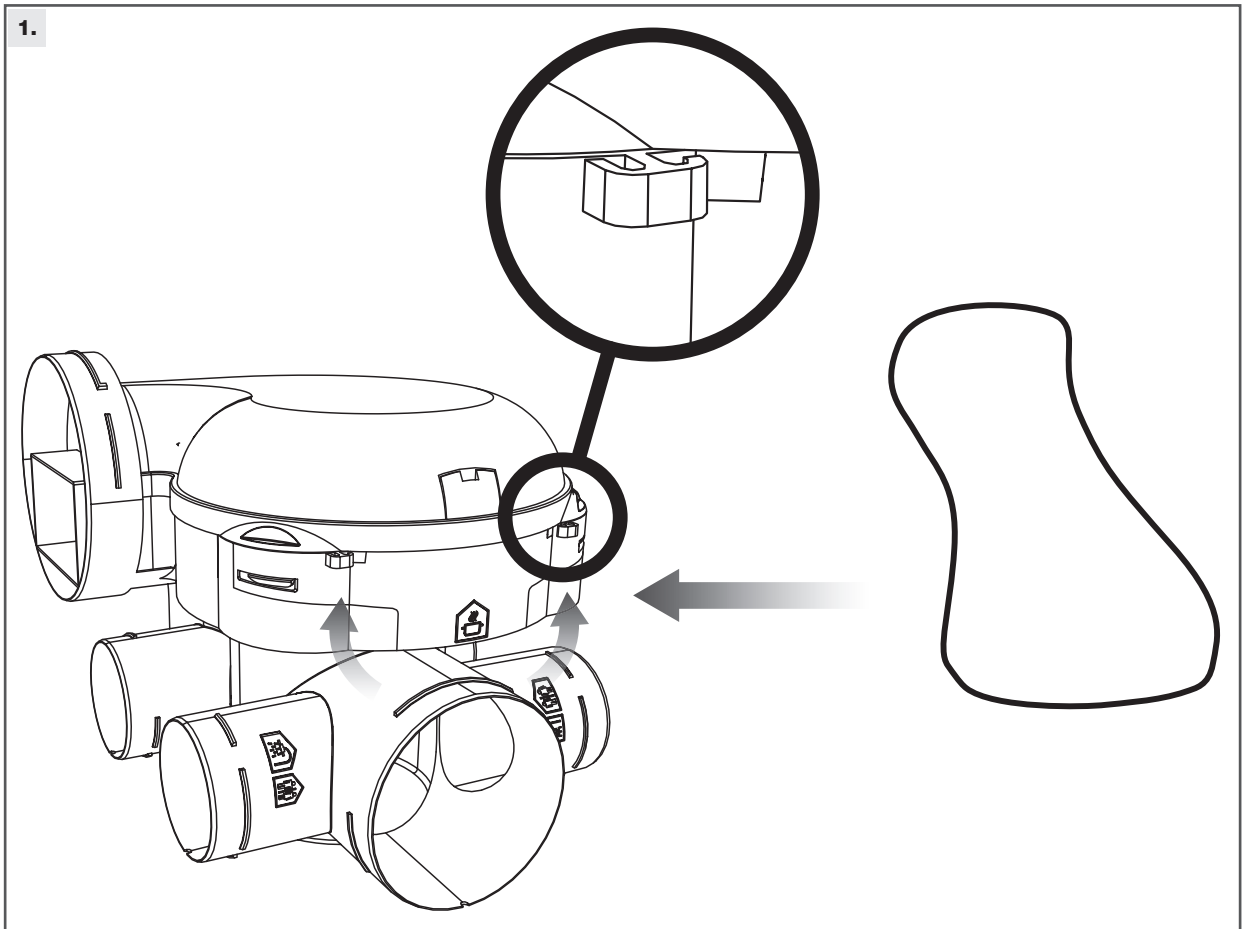

2.4. Montage vissé contre paroi (en option) • Screw attachment against wall (optional) •
 Montage durch Wandverschraubung (optional) • Schroefbevestiging op muur (optioneel) •
 Montaje con tornillos en pared (opción) • Montaggio avvitato a parete (opzionale)

Kit de fixation mural • Wall mounting kit • Wandmontage-Set • Muurbevestigingskit • Kit de fijación mural • Kit di fissaggio al muro

11033015

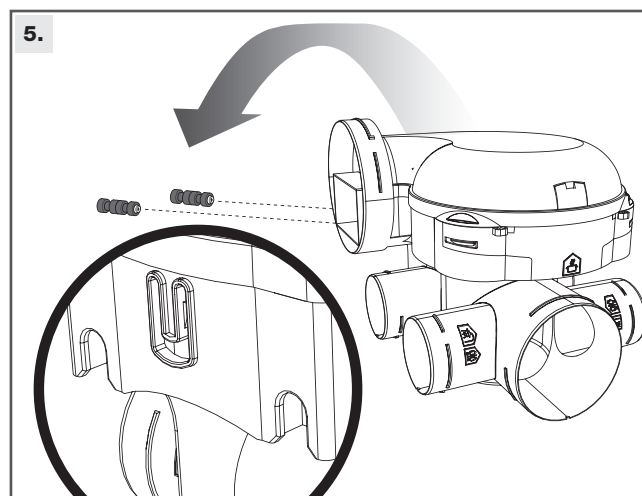
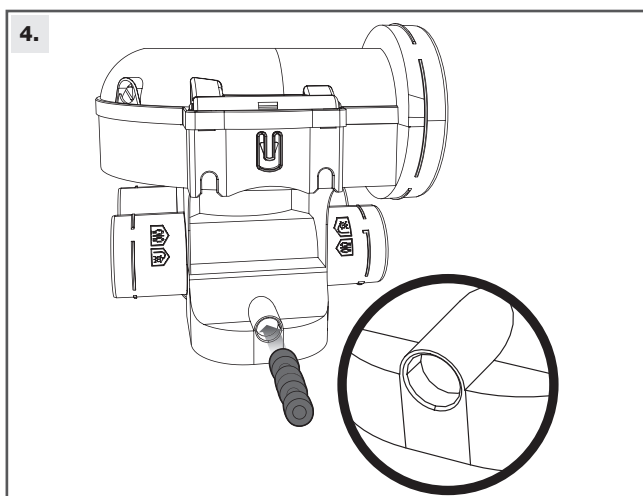
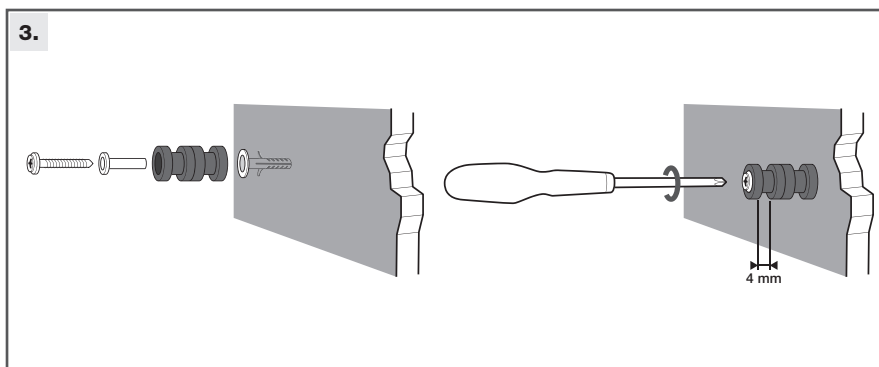
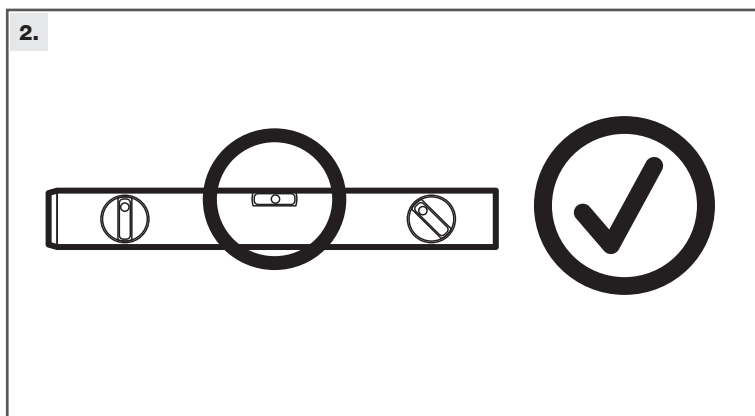
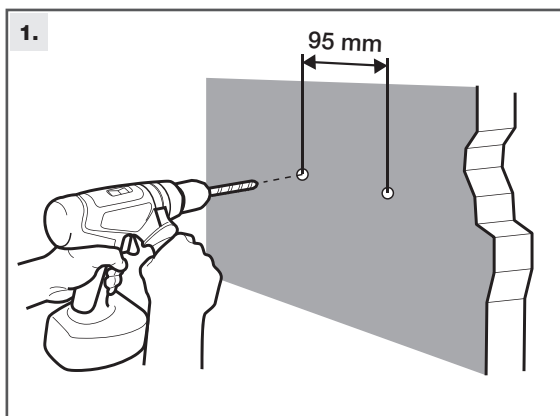
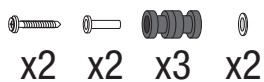

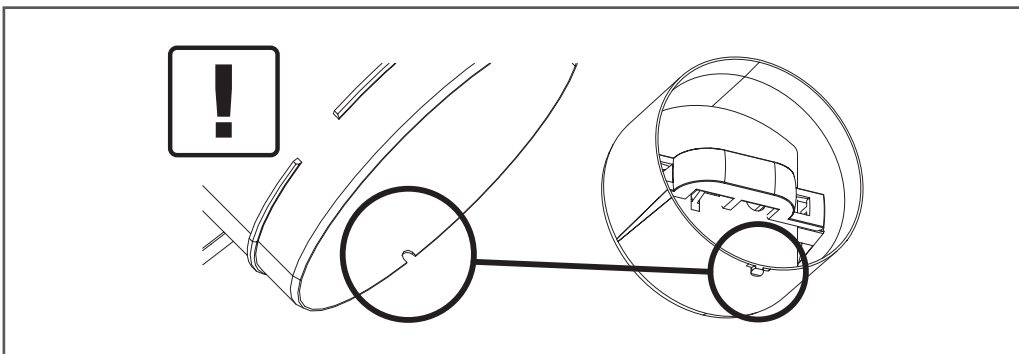
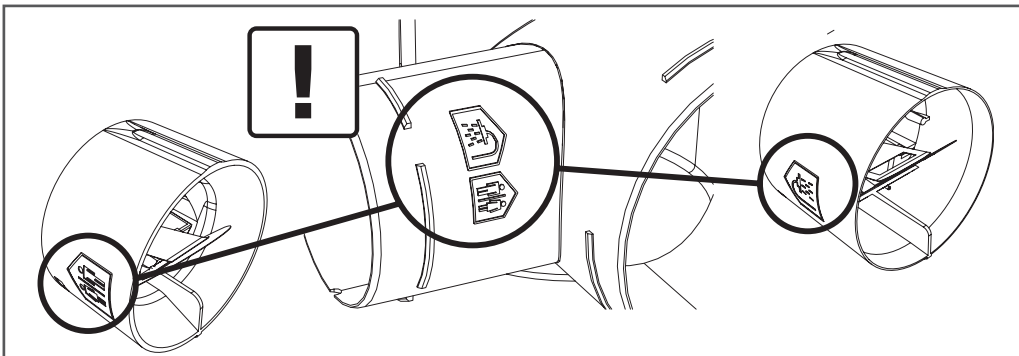
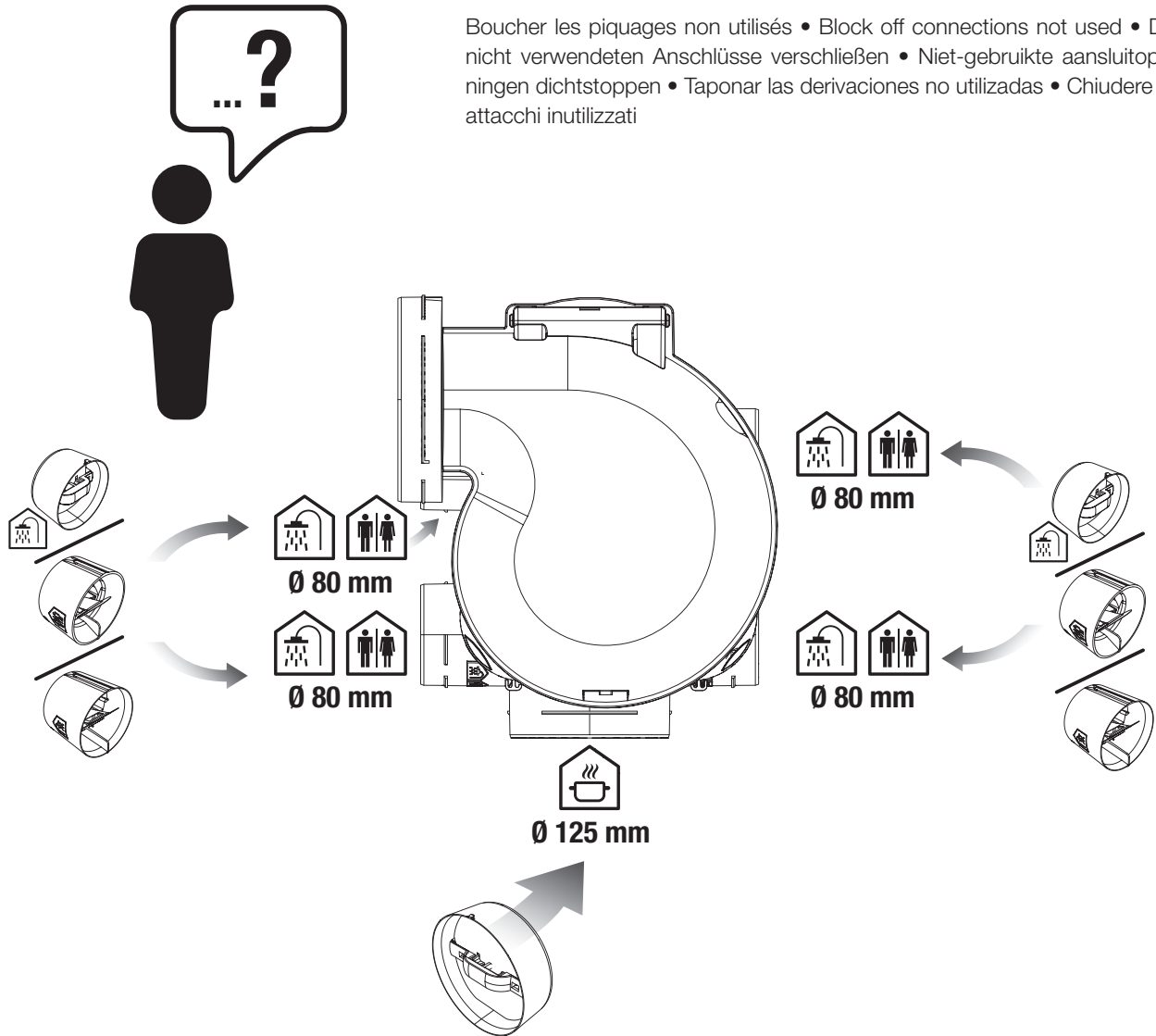

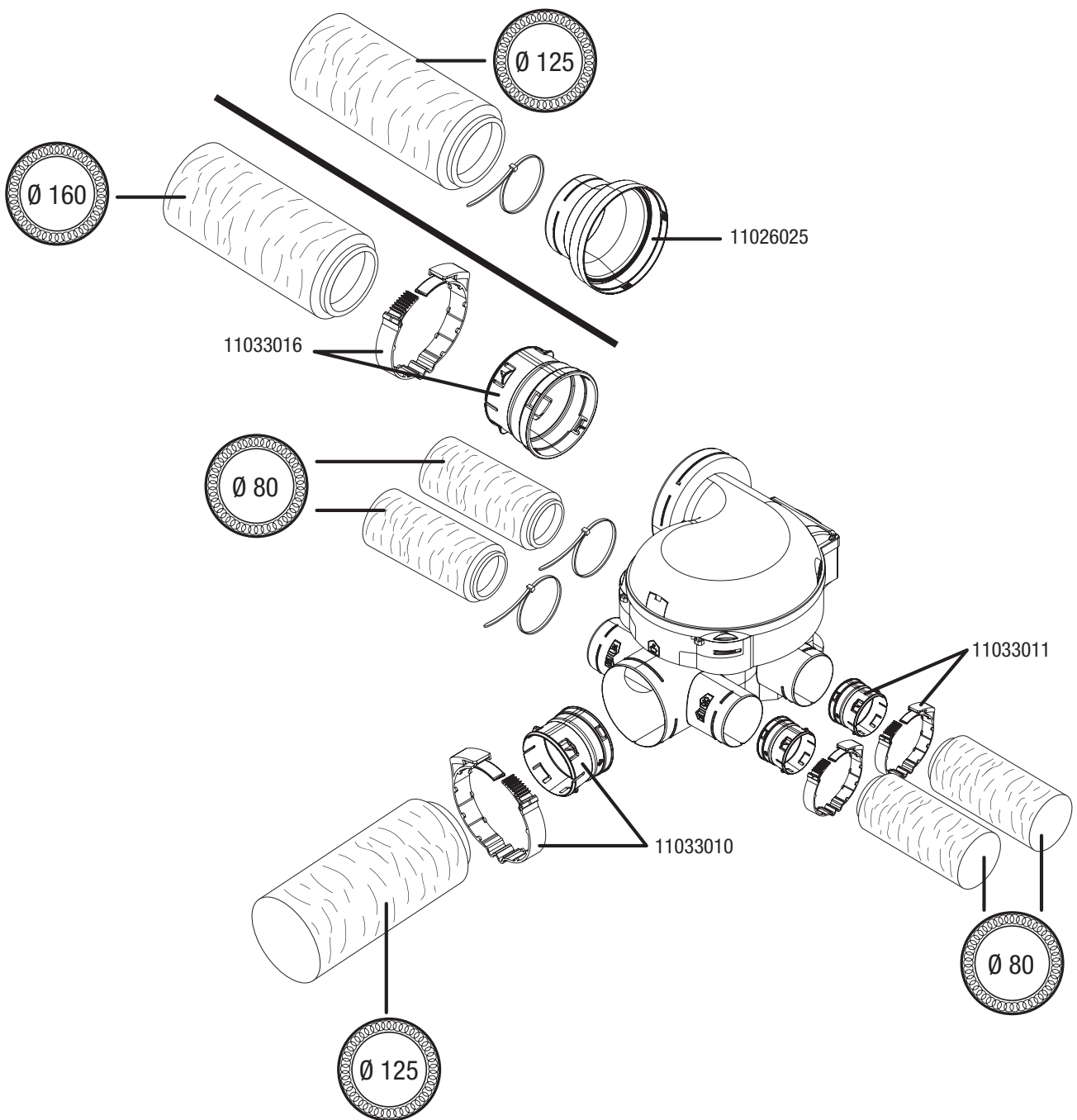

Hors volume chauffé, isoler le réseau • Isolate the network, ex. volume heated • Das Netz mit Ausnahme des beheizten Volumens isolieren • buiten verwarmde ruimte, het leidingstelsel isoleren • Fuera del volumen calentado, aislar la red • Isolare la rete al di fuori del volume riscaldato

Raccordement avec EasyClip Algaine (en option) • Connection using Algaine EasyClip (optional) • Anschluss mit EasyClip Algaine (optional)
• Verbinding met EasyClip Algaine (optioneel) • Conexionado con EasyClip Algaine (opción) • Raccordo con EasyClip Algaine (opzionale)

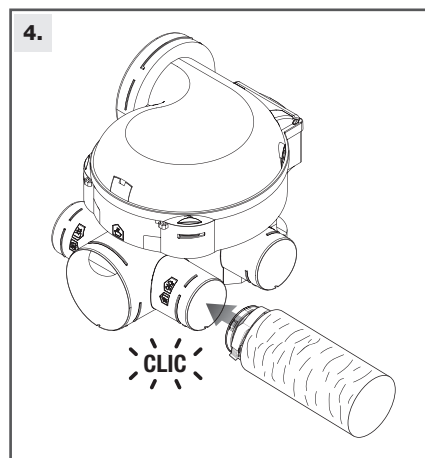
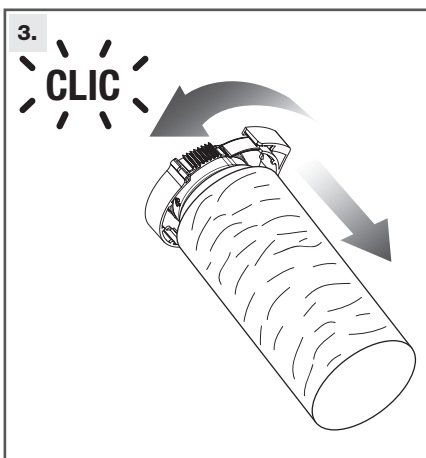
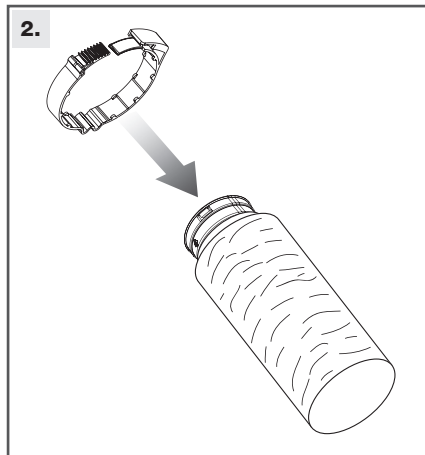
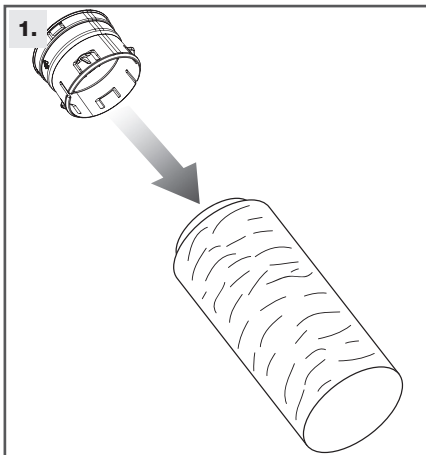

Installation dans les pièces techniques et humides • Installation in utility rooms and humid rooms • Installation in technischen Lokalen
und Feuchträumen • Installatie in technische en natte ruimtes • Instalación en las piezas técnicas y húmedas • Installazione in locali
tecnici e umidi

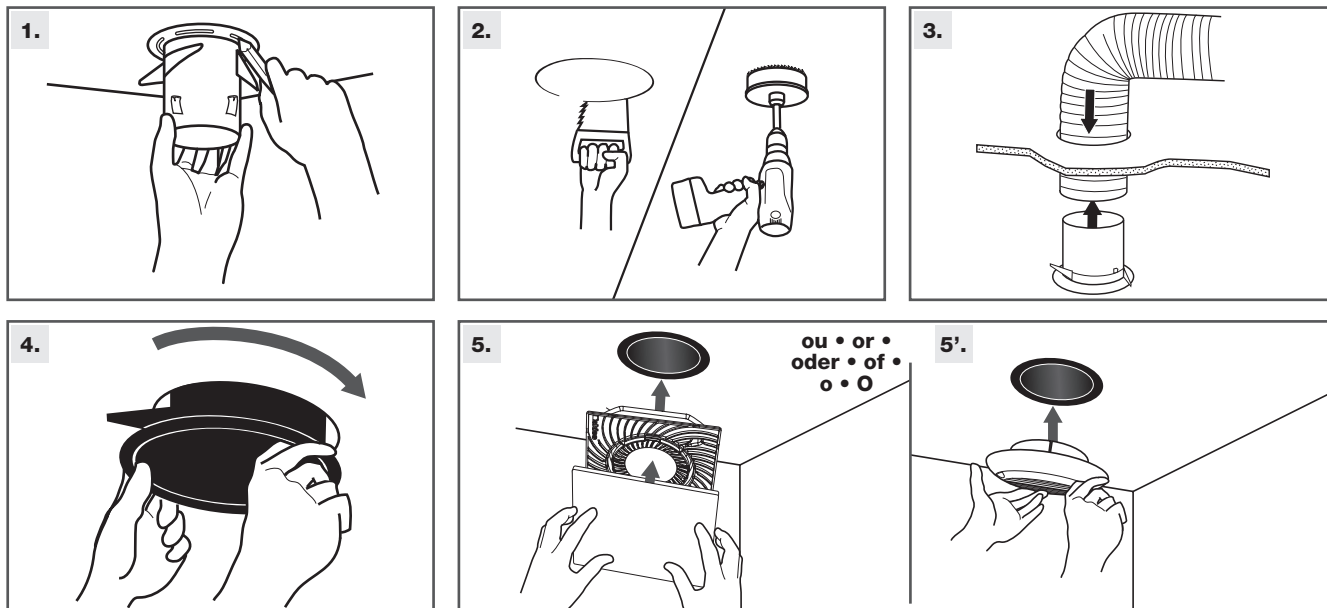

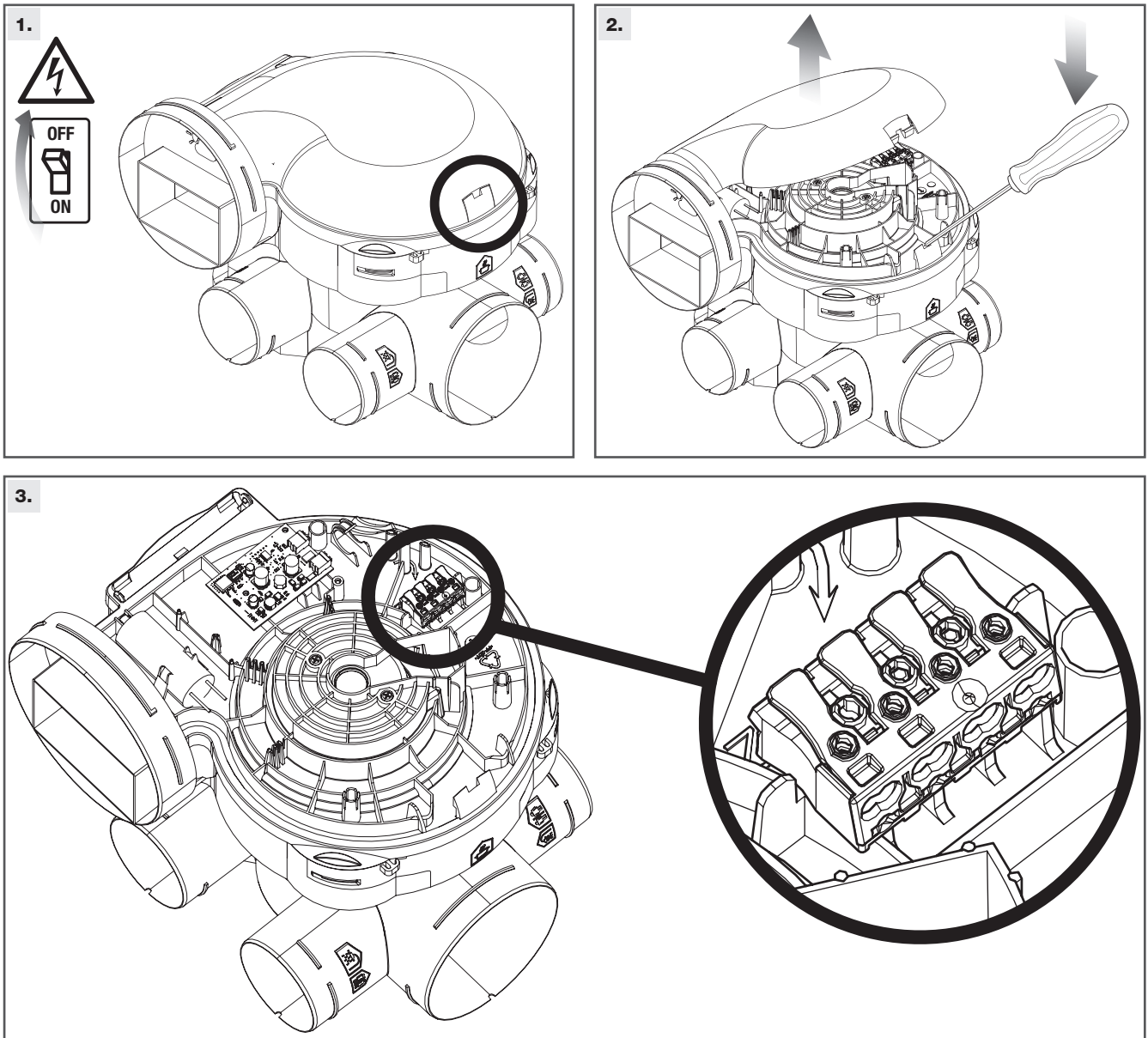

Version • Versie • Versión • Versione

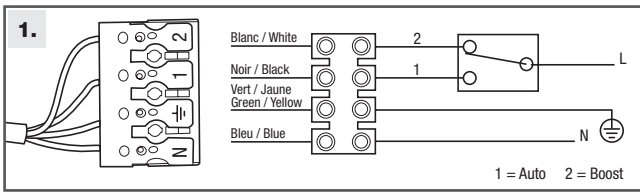

Auto CLASSIC

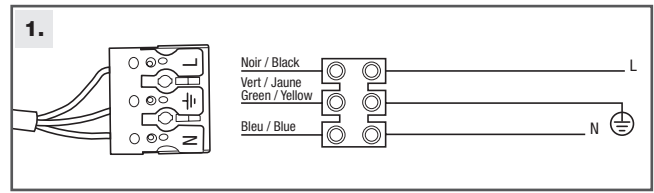

PureAIR CLASSIC

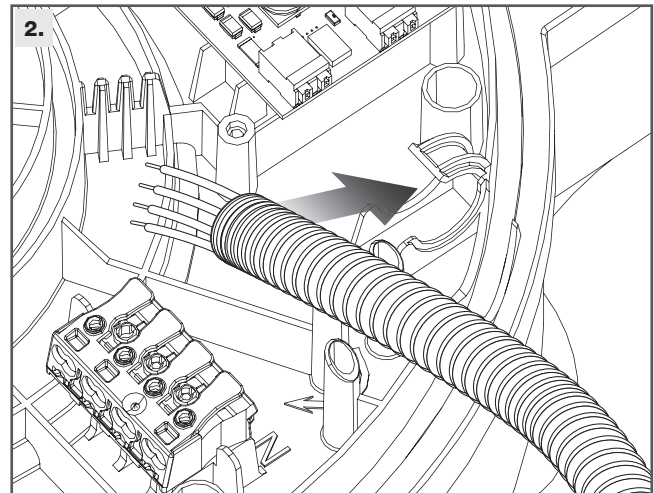
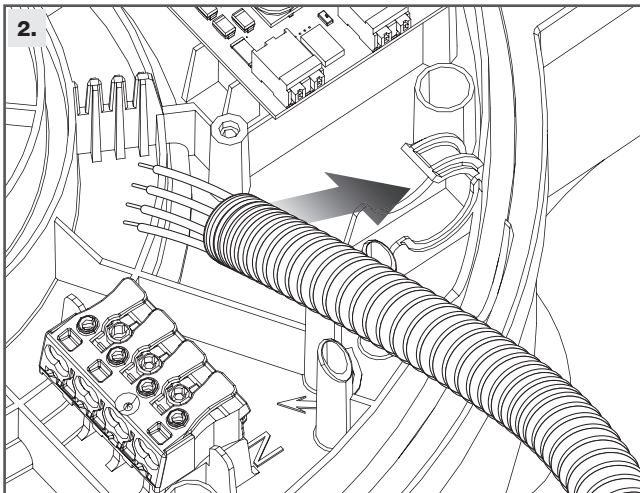

- 3.**
- | | |
|---------------------------------------|--------------------------------|
| FR Bouton poussoir (en option) | NL Drukknop (optioneel) |
| EN Push button (optional) | ES Pulsador (opción) |
| DE Druckknopf (optional) | IT Pulsante (opzionale) |

! **230 V** ⊗

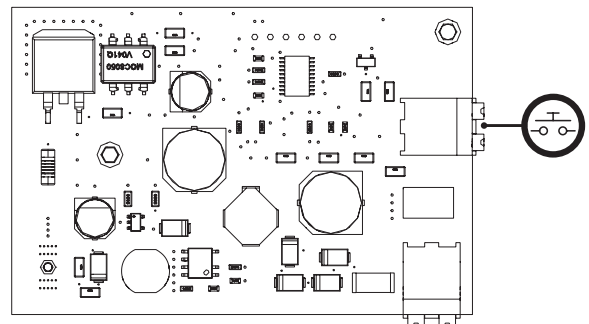

Pour conserver son efficacité et ses caractéristiques, le système de VMC doit être entretenu régulièrement. • To retain its efficiency and operating characteristics, the CMEV system must be serviced regularly. • Die Lüftungsanlage kann nur dann effizient bleiben und ihre normalen Leistungen bringen, wenn sie regelmäßig gewartet wird. • Om de doeltreffendheid en eigenschappen te behouden moet het mechanische ventilatiesysteem regelmatig worden onderhouden. • Para conservar su eficacia y sus propiedades, el sistema de VMC debe tener un mantenimiento regular. • Per mantenere la sua efficacia e le sue caratteristiche, il sistema di VMC deve essere oggetto di regolare manutenzione.



- Nettoyez les bouches d'extraction en se conformant aux instructions des notices jointes aux bouches
- Dépoussiérez les entrées d'air des pièces principales ou changez les filtres en se conformant aux instructions des notices jointes aux entrées d'air.

- Clean the exhaust terminals in accordance with the instructions provided
- Remove dust from air inlets in the main rooms or change the filters in accordance with the instructions provided.

- Die Abzugsöffnungen unter Einhaltung der Angaben in der beigelegten Anleitung reinigen
- Die Einlassöffnungen in den in den Wohnräumen abstauben oder die Filter unter Einhaltung der Angaben in der beigelegten Anleitung tauschen.

- Reinig de afzuigroosters volgens de gebruiksaanwijzingen die bij de roosters zijn meegeleverd.
- Verwijder het stof van de luchtinlaten van de belangrijkste ruimtes of vervang de filters volgens de gebruiksaanwijzingen die bij de inlaten zijn meegeleverd.

- Limpie las bocas de extracción siguiendo las instrucciones de los folletos entregados con las bocas
- Retire el polvo de las entradas de aire de las piezas principales o cambie los filtros siguiendo las instrucciones de los folletos entregados con las entradas de aire.

- Pulire le bocchette di estrazione attenendosi alle relative istruzioni allegate
- Spolverare le prese d'aria dei vani principali oppure sostituire i filtri conformemente alle istruzioni allegate alle prese d'aria.



- Dépoussiérez la roue du ventilateur à l'aide d'un pinceau. • Remove dust from the fan impeller using a brush. • Das Laufrad mit einem Pinsel abstauben. • Verwijder met een kwast het stof van de ventilatorwaaier. • Retire el polvo de la rueda del ventilador utilizando un pincel. • Spolverare la girante del ventilatore con un pennello.

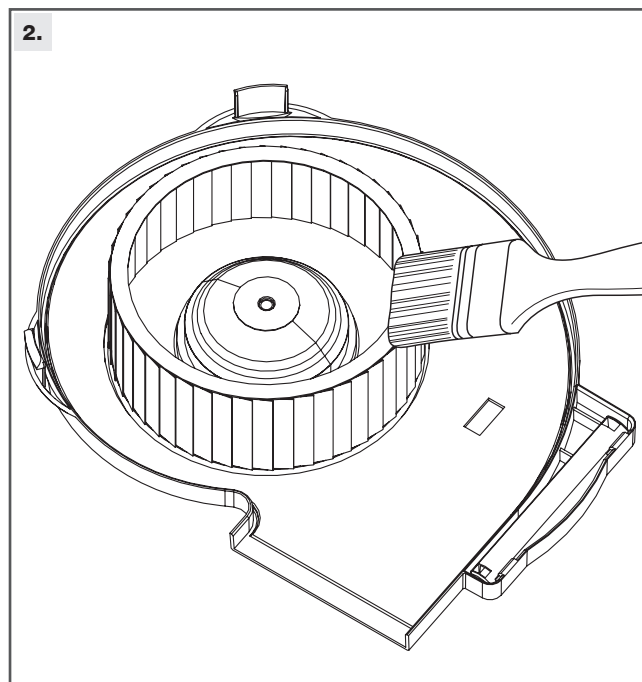
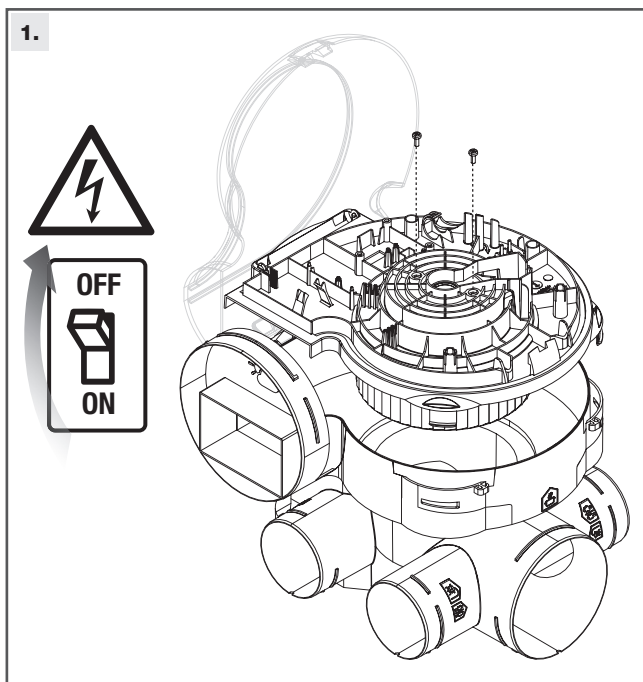

-
- FR** Les groupes EasyHOME Auto/PureAIR Classic sont garantis 5 ans / 2 ans sous réserve du respect des conditions de mise en œuvre, d'utilisation et d'entretien décrites dans la notice. A compter de la date d'achat. Facture du distributeur faisant foi.
- EN** EasyHOME Auto/PureAIR Classic units come with a 5-year / 2-year warranty subject to respect of the conditions of activation, use and servicing described in the instructions. Starts on the date of purchase. Date certified by distributor invoice.
- DE** Auf die EasyHOME Auto/PureAIR Classic Aggregate gibt es 5 Jahre / 2 Jahre Garantie unter dem Vorbehalt, dass die in den Anleitungen enthaltenen Vorschriften zur Montage, Benutzung und Instandhaltung eingehalten werden. Gilt ab dem Datum des Kaufs. Ausschlaggebend ist das Rechnungsdatum des Händlers.
- NL** De EasyHOME Auto/PureAIR Classic-groepen hebben 5 jaar / 2 jaar garantie, onder voorbehoud van de naleving van de voorwaarden voor de ingebruikname, het gebruik en het onderhoud beschreven in de gebruiksaanwijzingen. Gerekend vanaf de aankoopdatum. De factuur van de leverancier geldt als bewijs.
- ES** Los grupos EasyHOME Auto/PureAIR Classic tienen una garantía de 5 años / 2 años, bajo reserva de seguir las condiciones de montaje, de utilización y de mantenimiento descritas en los folletos. A partir de la fecha de la compra. La factura del distribuidor será fehaciente.
- IT** I gruppi EasyHOME Auto/PureAIR Classic sono garantiti 5 anni / 2 anni a condizione di rispettare le istruzioni di messa in opera, uso e manutenzione riportate nel manuale di istruzioni. A decorrere dalla data di acquisto. Fa fede la fattura del distributore.
-

EasyHOME AUTO / EasyHOME PUREAIR / Classic

FR



Marque commerciale fournisseur	Aldes	Aldes
Désignation	EasyHOME Auto	EasyHOME PureAIR Classic
Classe énergétique - Climat moyen	E	E
Climat moyen - SEC - Consommation énergétique spécifique (kWh/(m ² an))	-12.57	-18.20
Climat froid - SEC - Consommation énergétique spécifique (kWh/(m ² an))	-28.98	-39.13
Climat chaud - SEC - Consommation énergétique spécifique (kWh/(m ² an))	-3.18	-6.15
Type de Flux	SF	SF
Typologie déclarée	UVR	UVR
Type de motorisation installée ou prévue	2/ Two speed	2/ Two speed
Type de système de récupération de chaleur	N/A	N/A
Rendement thermique de récupération de chaleur (%)	N/A	N/A
Débit maximal de URV (m ³ /h)	241	241
Puissance électrique absorbée à Qmax (W)	28.9	28.9
LwA - Niveau de puissance acoustique (dB)	45	45
Débit de référence (m ³ /s)	0.05	0.050
Différence de pression de référence (Pa)	135	135
SPI (W/(m ³ /h))	0.15	0.15
Facteur de régulation (%)	1	0.85
Typologie de régulation	Manual Control	Central Demand Control
Taux de fuite interne maximal en dépression déclaré pour DF (%)	N/A	N/A
Taux de fuite externe maximal en dépression déclaré pour SF et DF (%)	5.3	5.3
Taux de fuite interne maximal en surpression déclaré pour DF (%)	N/A	N/A
Taux de fuite externe maximal en surpression déclaré pour SF et DF (%)	N/A	N/A
Taux de mélange des unités double flux décentralisées sans piquage (%)	N/A	N/A
Position de l'alarme visuelle	N/A	N/A
Description de l'alarme visuelle	N/A	N/A
Remplacement régulier des filtres pour les performances et l'efficacité énergétique de l'unité	N/A	N/A
Instruction d'installation des entrées d'air neuf	Cf. Notice	Cf. Notice
Sensibilité du flux d'air aux variations de pression à + 20 Pa	N/A	N/A
Sensibilité du flux d'air aux variations de pression à - 20 Pa	N/A	N/A
Etanchéité à l'air intérieur/extérieur (m ³ /h)	N/A	N/A
Consommation d'électricité annuelle - CEA (kWh électricité/an)	183	151
Climat moyen - EAC - Economie annuelle de chauffage (kWh énergie primaire/an)	1715	2193
Climat froid - EAC - Economie annuelle de chauffage (kWh énergie primaire/an)	3355	4290
Climat chaud - EAC - Economie annuelle de chauffage (kWh énergie primaire/an)	776	992

EasyHOME AUTO / EasyHOME PUREAIR / Classic

EN



Supplier brand	Aldes	Aldes
Designation	EasyHOME Auto	EasyHOME PureAIR Classic
Energy class - Average climate	E	E
Average climate - SEC - Specific energy consumption (kWh/(m ² a year))	-12.57	-18.20
Cold climate - SEC - Specific energy consumption (kWh/(m ² a year))	-28.98	-39.13
Warm climate - SEC - Specific energy consumption (kWh/(m ² a year))	-3.18	-6.15
Type of airflow	SF	SF
Declared type	UVR	UVR
Type of motor installed or planned	2/ Two speed	2/ Two speed
Type of heat recovery system	N/A	N/A
Thermal efficiency of heat recovery (%)	N/A	N/A
Maximum RVU (m ³ /h)	241	241
Electric power absorbed at Qmax (W)	28.9	28.9
LwA - Sound power level (dB)	45	45
Reference airflow (m ³ /s)	0.05	0.050
Difference in reference pressure (Pa)	135	135
SPI (W/(m ³ /h))	0.15	0.15
Control factor (%)	1	0.85
Type of control system	Manual Control	Central Demand Control
Maximum declared internal leakage rate under negative pressure for BVU (%)	N/A	N/A
Maximum declared external leakage rate under negative pressure for UVU and BVU (%)	5.3	5.3
Maximum declared internal leakage rate under positive pressure for BVU (%)	N/A	N/A
Maximum declared external leakage rate under positive pressure for UVU and BVU (%)	N/A	N/A
Mixing rate for standalone BVU without branch connections (%)	N/A	N/A
Position of visual alarm	N/A	N/A
Description of visual alarm	N/A	N/A
Regular replacement of filters to ensure unit performance and energy efficiency	N/A	N/A
Instructions for installation of fresh air inlets	Cf. Notice	Cf. Notice
Sensitivity of airflow to pressure variations at +20 Pa	N/A	N/A
Sensitivity of airflow to pressure variations at -20 Pa	N/A	N/A
Indoor/outdoor air tightness (m ³ /h)	N/A	N/A
Annual electricity consumption (kWh electricity/a year)	183	151
Average climate - AHS - Annual heating savings (kWh primary energy/a year)	1715	2193
Cold climate - AHS - Annual heating savings (kWh primary energy/a year)	3355	4290
Warm climate - AHS - Annual heating savings (kWh primary energy/a year)	776	992

EasyHOME AUTO / EasyHOME PUREAIR / Classic

DE



Handelsmarke des Lieferanten	Aldes	Aldes
Bezeichnung	EasyHOME Auto	EasyHOME PureAIR Classic
Energieklasse - Durchschnittliches Klima	E	E
Durchschnittliches Klima - SEC - Spezifischer Energieverbrauch(kWh/(m ² a))	-12.57	-18.20
Kaltes Klima - SEC - Spezifischer Energieverbrauch (kWh/(m ² a))	-28.98	-39.13
Warmes Klima - SEC - Spezifischer Energieverbrauch (kWh/(m ² a))	-3.18	-6.15
Strömungsarten	SF	SF
Deklarierte Typologie	UVR	UVR
Installierter oder vorgesehener Motorisierungstyp	2/ Two speed	2/ Two speed
Art des Wärmerückgewinnungssystems	N/A	N/A
Wärmeleistung der Wärmerückgewinnung (%)	N/A	N/A
Maximaler URV Volumenstrom (m ³ /h)	241	241
Elektrische Leistungsaufnahme bei Qmax (W)	28.9	28.9
LwA - Geräuschemissionsniveau (dB)	45	45
Referenzvolumenstrom (m ³ /s)	0.05	0.050
Referenzdruckunterschied	135	135
SPI (W/(m ³ /h))	0.15	0.15
Regelfaktor	1	0.85
Regeltypologie	Manual Control	Central Demand Control
Maximale interne Leckrate bei Unterdruck für BVU (%)	N/A	N/A
Maximale externe Leckrate bei Unterdruck für SF und DF (%)	5.3	5.3
Maximale interne Leckrate bei Überdruck für DF (%)	N/A	N/A
Maximale externe Leckrate bei Überdruck für SF und DF (%)	N/A	N/A
Mischrate der dezentralisierten Einheiten mit Wärmerückgewinnung ohne Abzweigung (%)	N/A	N/A
Position des optischen Alarms	N/A	N/A
Beschreibung des optischen Alarms	N/A	N/A
Regelmäßiger Filtertausch für die entsprechenden Leistungen und Energieeffizienz der Einheit	N/A	N/A
Installationsanleitung für die Frischluftzuführungen	Cf. Notice	Cf. Notice
Empfindlichkeit des Luftstroms gegenüber Druckschwankungen bei + 20 Pa	N/A	N/A
Empfindlichkeit des Luftstroms gegenüber Druckschwankungen bei - 20 Pa	N/A	N/A
Luftdichtheit innen/ außen (m ³ /h)	N/A	N/A
Jahresstromverbrauch - AEC (kWh Elektrizität/a)	183	151
Mittleres Klima - AHS - Jährliche Heizkostensparnis (kWh Primärenergie/a)	1715	2193
Kaltes Klima - AHS - Jährliche Heizkostensparnis (kWh Primärenergie/a)	3355	4290
Warmes Klima - AHS - Jährliche Heizkostensparnis (kWh Primärenergie/a)	776	992

EasyHOME AUTO / EasyHOME PUREAIR / Classic

NL



Merknaam leverancier	Aldes	Aldes
Benaming	EasyHOME Auto	EasyHOME PureAIR Classic
Energieklasse - Gematigd klimaat	E	E
Gematigd klimaat - SEC - specifiek energetisch verbruik (kWh/(m ² a))	-12.57	-18.20
Koud klimaat - SEC - specifiek energetisch verbruik (kWh/(m ² a))	-28.98	-39.13
Warm klimaat - SEC - Specifiek energieverbruik (kWh/(m ² a))	-3.18	-6.15
Flow type	SF	SF
Opgegeven Typologie	UVR	UVR
Motor type geïnstalleerd of voorzien	2/ Two speed	2/ Two speed
Soort warmteterugwinning systeem	N/A	N/A
Thermisch rendement warmteterugwinning (%)	N/A	N/A
Maximaler URV Volumenstrom (m ³ /h)	241	241
Geabsorbeerd elektrisch vermogen bij Qmax (W)	28.9	28.9
LwA - Geluidsvermogeniveau (dB)	45	45
Referentie debiet (m ³ /s)	0.05	0.050
Referentie drukverschil (Pa)	135	135
SPI (W/(m ³ /h))	0.15	0.15
Regulatie factor (%)	1	0.85
Regelinstypologie	Manual Control	Central Demand Control
Aangegeven maximaal percentage voor (%) interne lekkage bij onderdruk voor tweerichtings-RVE	N/A	N/A
Aangegeven maximaal percentage voor externe lekkage bij onderdruk voor één- en tweerichtings-RVE (%)	5.3	5.3
Aangegeven maximaal percentage voor interne lekkage bij overdruk voor tweerichtings-RVE (%)	N/A	N/A
Aangegeven maximaal percentage voor externe lekkage bij overdruk voor één- en tweerichtings-RVE (%)	N/A	N/A
Mengpercentage van tweerichtingsventilatie-eenheden zonder luchtkanalen (%)	N/A	N/A
Plaats van het visueel waarschuwingssignaal	N/A	N/A
Beschrijving van het visueel waarschuwingssignaal	N/A	N/A
Geregelde vervanging van de filters voor het rendement en de energie-efficiëntie van de eenheid	N/A	N/A
Installatie-instructies voor aanzuigroosters van verse lucht	Cf. Notice	Cf. Notice
Gevoeligheid van de luchtstroom voor drukvariëaties van + 20 Pa	N/A	N/A
Gevoeligheid van de luchtstroom voor drukvariëaties van - 20 Pa	N/A	N/A
Interne/externe luchtdichtheid (m ³ /h)	N/A	N/A
Jaarlijks elektrisch verbruik - AEC (kWh elektriciteit/a)	183	151
Gematigd klimaat - AHS - Jaarlijkse besparing op verwarming (kWh primaire energie/a)	1715	2193
Koud klimaat - AHS - Jaarlijkse besparing op verwarming (kWh primaire energie/a)	3355	4290
Warm klimaat - AHS - Jaarlijkse besparing op verwarming (kWh primaire energie/a)	776	992

EasyHOME AUTO / EasyHOME PUREAIR / Classic

ES



Marca comercial proveedor	Aldes	Aldes
Denominación	EasyHOME Auto	EasyHOME PureAIR Classic
Clase energética - Clima templado	E	E
Clima templado - CEE - Consumo de energía específico (kWh/(m ² a))	-12.57	-18.20
Clima frío - CEE - Consumo de energía específico (kWh/(m ² a))	-28.98	-39.13
Clima cálido - CEE - Consumo de energía específico (kWh/(m ² a))	-3.18	-6.15
Tipo de flujo	SF	SF
Tipo declarado	UVR	UVR
Tipo de accionamiento instalado o que va a instalarse	2/ Two speed	2/ Two speed
Tipo de sistema de recuperación de calor	N/A	N/A
Eficiencia térmica de recuperación de calor (%)	N/A	N/A
Caudal máximo de UVR (m ³ /h)	241	241
Potencia eléctrica absorbida a Q _{máx} (W)	28.9	28.9
L _{wA} - Nivel de potencia acústica (dB)	45	45
Caudal de referencia (m ³ /s)	0.05	0.050
Diferencia de presión de referencia	135	135
SPI (W/(m ³ /h))	0.15	0.15
Factor del mando	1	0.85
Tipo de mando	Manual Control	Central Demand Control
Índice máximo declarado de fuga externa en depresión para DF (%)	N/A	N/A
Índice máximo declarado de fuga externa en depresión para SF y DF (%)	5.3	5.3
Índice máximo declarado de fuga externa en sobrepresión para DF (%)	N/A	N/A
Índice máximo declarado de fuga externa en sobrepresión para SF y DF (%)	N/A	N/A
Índice de mezcla de unidades doble flujo descentralizadas sin conexión a conductos (%)	N/A	N/A
Posición de la alarma visual	N/A	N/A
Descripción de la alarma visual	N/A	N/A
Cambio con regularidad de los filtros para el rendimiento y la eficiencia energética de la unidad	N/A	N/A
Instrucción de instalación de las entradas de aire nuevo	Cf. Notice	Cf. Notice
Sensibilidad del flujo de aire a las variaciones de presión a + 20 Pa	N/A	N/A
Sensibilidad del flujo de aire a las variaciones de presión a - 20 Pa	N/A	N/A
Estanqueidad al aire interior/exterior (m ³ /h)	N/A	N/A
Consumo eléctrico anual - CEA (kWh de electricidad/a)	183	151
Clima templado - EAC - Economía anual de calefacción (kWh de energía primaria/a)	1715	2193
Clima frío - EAC - Economía anual de calefacción (kWh de energía primaria/a)	3355	4290
Clima cálido - EAC - Economía anual de calefacción (kWh de energía primaria/a)	776	992

EasyHOME AUTO / EasyHOME PUREAIR / Classic

IT



Marchio commerciale fornitore	Aldes	Aldes
Designazione	EasyHOME Auto	EasyHOME PureAIR Classic
Classe energetica - Clima medio	E	E
Clima medio - SEC - Consumo energetico specifico (kWh/(m ² a))	-12.57	-18.20
Clima freddo - SEC - Consumo energetico specifico (kWh/(m ² a))	-28.98	-39.13
Clima caldo - SEC - Consumo energetico specifico (kWh/(m ² a))	-3.18	-6.15
Tipo di flusso	SF	SF
Tipologia dichiarata	UVR	UVR
Tipo di motore installato o previsto	2/ Two speed	2/ Two speed
Tipo di sistema di recupero del calore	N/A	N/A
Rendimento termico di recupero di calore (%)	N/A	N/A
Portata massima di URV (m ³ /h)	241	241
Potenza elettrica assorbita a Qmax (W)	28.9	28.9
LwA - Livello di potenza acustica (dB)	45	45
Portata di riferimento (m ³ /s)	0.05	0.050
Differenza di pressione di riferimento	135	135
SPI (W/(m ³ /h))	0.15	0.15
Fattore di regolazione	1	0.85
Tipologia di regolazione	Manual Control	Central Demand Control
Tasso di trafilamento interno max in depressione dichiarato per DF (%)	N/A	N/A
Tasso di trafilamento esterno max in depressione dichiarato per SF e DF (%)	5.3	5.3
Tasso di trafilamento interno max in sovrappressione dichiarato per DF (%)	N/A	N/A
Tasso di trafilamento esterno max in sovrappressione dichiarato per SF e DF (%)	N/A	N/A
Tasso di miscela delle unità doppio flusso decentralizzate, non canalizzate (%)	N/A	N/A
Posizione dell'allarme ottico	N/A	N/A
Descrizione dell'allarme ottico	N/A	N/A
Sostituzione regolare dei filtri per le prestazioni e l'efficienza energetica dell'unità	N/A	N/A
Istruzioni di installazione degli ingressi dell'aria di rinnovo	Cf. Notice	Cf. Notice
Sensibilità del flusso d'aria alle variazioni di pressione a + 20 Pa	N/A	N/A
Sensibilità del flusso d'aria alle variazioni di pressione a - 20 Pa	N/A	N/A
Tenuta all'aria interna/esterna (m ³ /h)	N/A	N/A
Consumo annuale di elettricità - AEC (kWh di elettricità/a)	183	151
Clima medio - AHS - Risparmio annuale di riscaldamento (kWh di energia primaria/a)	1715	2193
Clima freddo - AHS - Risparmio annuale di riscaldamento (kWh di energia primaria/a)	3355	4290
Clima caldo - AHS - Risparmio annuale di riscaldamento (kWh di energia primaria/a)	776	992



FRANCE

Besoin d'une assistance technique après-vente ou d'une demande de prestation service Aldes ?

- Vous êtes un client professionnel : 09 69 32 39 98 (n° Cristal, prix d'un appel local) • ata.stve@aldes.com
- Vous êtes un client particulier : 09 69 32 39 74 (n° Cristal, prix d'un appel local) • service-conso@aldes.com

BELGIUM

Besoin d'une assistance technique après-vente ?

Rendez-vous sur notre site web pour plus d'informations : www.aldesbenelux.com/fr/sav/

Technische after sales ondersteuning nodig?

Bezoek onze website voor meer informatie: www.aldesbenelux.com/nl/dienst-na-verkoop/

ITALY

Per ulteriori informazioni : www.aldes.it • aldes.italia@aldes.com

Per supporto post-vendita : service.italia@aldes.com

SPAIN

¿Necesidad de una asistencia técnica posventa?

www.aldes.es/documentacion-y-soporte/postventa-repuestos • sat.es@aldes.com • +34 91 174 37 86

GERMANY

Technische Unterstützung notwendig?

- Sie sind Profi-Kunde: +49 (0) 6721-9178 112 • service@exhausto.de • +49 (0) 6721-9178 112

- Sie sind Privatkunde: Bitte wenden Sie sich an Ihren örtlichen Installateur oder einen Lüftungsprofi Ihrer Wahl.

DENMARK

Har du behov for teknisk support?

Find kontaktoplysninger til EXHAUSTO her: www.exhausto.dk/service

SWEDEN

Behöver du teknisk support?

Hitta kontaktinformation för EXHAUSTO här: www.exhausto.se/service

NORWAY

Trenger du teknisk support?

Finn kontaktinformasjon for EXHAUSTO her: www.exhausto.no/service

OTHER COUNTRIES

Need after sales technical support?

Visit our website for more information: <https://www.aldes-international.com/fr/contact/>



Séparez les éléments avant de trier

Aldes-EasyHOMEAutoClassicPureAIRClassic-Inst-Corp-

11028849D

092023

RCS Lyon 956 506 828

Aldes se réserve le droit d'apporter à ses produits toutes modifications liées à l'évolution de la technique.

Visuels non contractuels Crédits photos: Getty Images / iStockphoto / AldesGroupe