

Outlet and terminal

11015419

The BAHIA CURVE humidity-controlled terminal for bathrooms and WC ensures sufficient and constant extraction of indoor pollution according to the humidity level in the room.



PRODUCT BENEFITS

- easy to install,
- simple to clean,
- unique no-grille design conserves the aesthetic character of the terminal even if it is clogged.

REGULATIONS AND COMPLIANCES

Identification no. QB37 : 05/02-CHY3-2266;05/02-CHY3-2267;05/02-CHY3-2185
 Technical Opinion no. : 14.5/17-2267;14.5/17-2266;14.5/17-2185

Principles of operation

In a humidity-controlled CMEV system, the airflow is automatically controlled according to the humidity level in rooms and therefore based on the actual ventilation needs of the building. The BAHIA CURVE S terminal is installed in bathrooms/WC.

Product description

BAHIA CURVE S is a humidity-controlled extract terminal designed for utility rooms in individual houses, new and refurbished multi-occupancy residential housing. This terminal is the small model for airflow needs < 50 m³/h.

Fields of application

Multi-occupancy residential housing, Individual residential housing, New, Refurbishment

Installation

- BAHIA CURVE S must be installed in humid rooms or equipment rooms: bathrooms, WC, cellar, etc.
- the terminal must be located at the top of a vertical wall or on the ceiling at least 1.80 m from the floor,
- the terminal must be accessible and removable with a distance of at least 20 cm between the centre of the terminal and the adjacent walls and not glued to the duct,
- the air tightness of the terminal - duct connection must be optimal. This is achieved with O-ring seals and reinforced with a sleeve. A sheet metal sleeve is used for multi-occupancy housing (stainless steel sleeve required for a gas CMEV system). A plastic sleeve may be used for an individual house. The sleeves are slotted directly into: - a semi-rigid or rigid duct Ø 125 mm correctly shaped, a sheet metal sleeve Ø 125 mm (code 11012220),
- the terminal is slotted directly into: a sleeve, RT Flex, rigid or semi-rigid ducts. The airtight seal is created with O-ring seals and reinforced with a sleeve.
- versions with shaft D 80 mm, slots into sleeves, rigid and semi-rigid ducts.
- If cord-operated grilles are installed in the ceiling or above a piece of furniture, use a cord return system (code 11015001).
- Note: For humidity-controlled terminals with electrical controls, a 9V alkaline battery type 6LR61 is required as well as a conventional push button (code 11026011).
- Humidity-controlled terminals operate within the 80-160 Pa pressure range.
- Extract terminals must be maintained and checked at least once a year. Never connect a mechanical extractor hood to the CMEV network (article 14 of Decision of 24 March 1982),
- Before replacing an old terminal with a new one, measure the pressure and identify the type of dwelling.

Outlet and terminal

11015419

Main characteristics

- humidity-controlled terminal, small size (airflow < 50 m³/h),
- versions and accessories to meet all installation needs,
- easy maintenance: control sub-assembly quick to clip on and unclip, easy to clean without being removed from the wall thanks to its removable Bahia Curve casing,
- pressure range: 80 - 160 Pa.

General data

Variants	Main material
11015419	Plastic

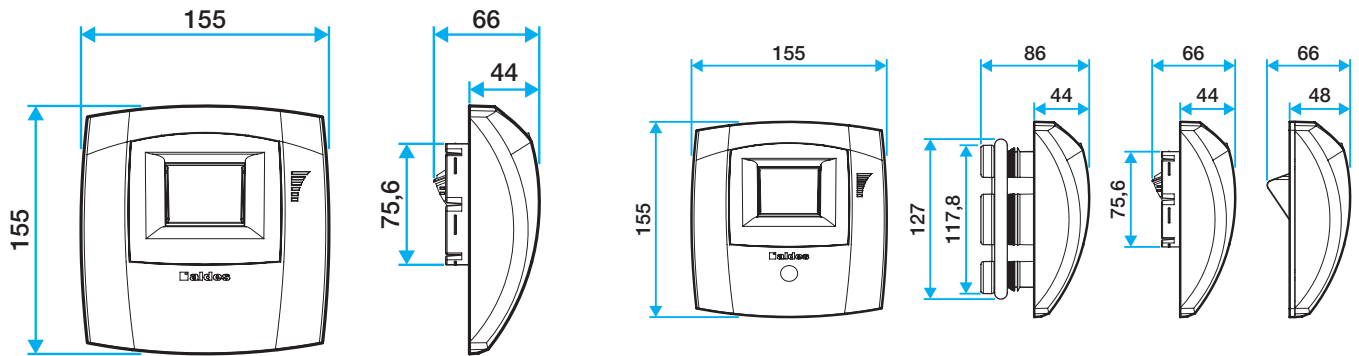

Installation

