

Wall grille

11002201

AC 102D

The AC 102 D wall grille enables air supply on all ventilation and air-conditioning systems.



Grille AC 102D

PRODUCT BENEFITS

- adjustable vanes,
- aesthetic,
- easy to install / remove.

Principles of operation

The AC 102 D dual-deflection has individually dirigible horizontal and vertical vanes to adjust the air supply level in a room.

Product description

The AC 102 D is a steel dual deflection wall-mounted grille with individually adjustable, movable horizontal rear and vertical front vanes.

Fields of application

New, Refurbishment, Non-residential buildings

Installation

- wall installation,
- concealed F3 attachment using friction clips.

Main characteristics

- anodised aluminium, natural satin colour,
- individually dirigible horizontal rear and vertical front vanes, 20 mm pitch.

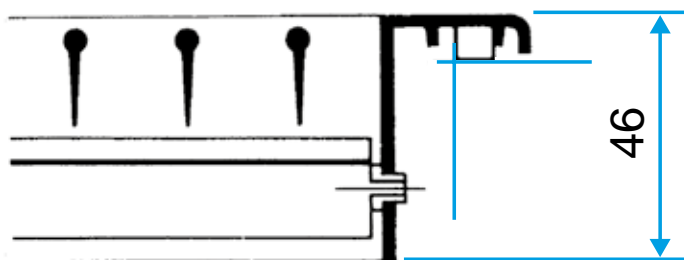

Grille AC 102 D seule

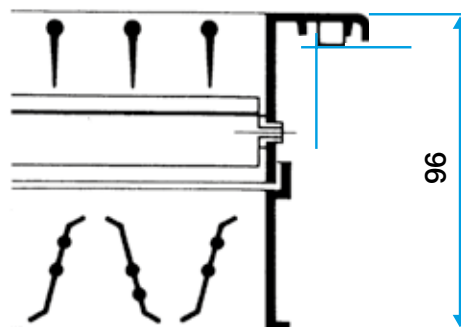

Grille AC 102 D avec registre AGB ou SGS monté