

# 11003243

## AP 639 H 600

The AP 639 penthouse delivers fresh air intake or contaminated air outlet on ventilation and smoke / heat exhaust systems.



AP 639 H 600 EDIGULE TOITURE ALU

### PRODUCT BENEFITS

- roof outlet suited to natural smoke and heat exhaust airflows,
- rain guard,
- robust grille specially designed to prevent intrusion.

### Principles of operation

The AP 639 penthouse is installed on the roof at the end of an air intake or outlet duct, to exchange air between the building and outside, while preventing the ingress of rain or intrusion.

### Product description

The AP 639 is an aluminium penthouse suited to ventilation systems and natural or mechanical smoke and heat exhaust systems. It enables air intake or exhaust for the building.

### Fields of application

Multi-occupancy residential housing, New, Refurbishment, Non-residential buildings

### Installation

- lifting lugs included for installation on roof,
- visible screw attachment to the chassis,
- installed on concrete stack base. The base of the penthouse features an I-shape frame to cover the stack base,
- metal base plate available for flat roof as accessory.

### Main characteristics

- aluminium frame and horizontal rain guard vanes,
- last vane at bottom set in "water run-off" position,
- aluminium cap,
- vane pitch 100 mm,
- available heights:
  - 300 mm,
  - 400 mm,
  - 500 mm,
  - 600 mm,
  - 800 mm,
- inner section containing galvanised steel 12 x 12 Ø 1.2 mm square mesh as a bird screen,
- rough aluminium finish..

### Options

ANOD
GRAV
RAL1
RAL2
RAL4
SP

11003243  
AP 639 H 600

Dimensional data

References	H (mm)
11003243	600

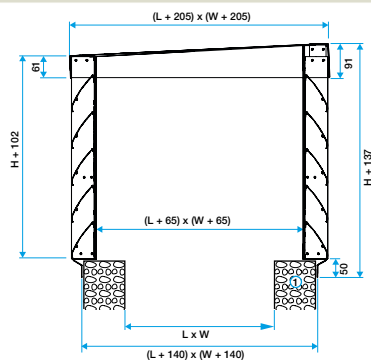

AP 639 penthouse

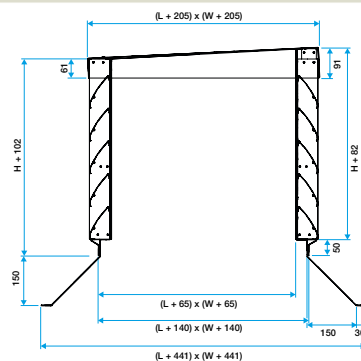

AP 639 penthouse with metal stack base for flat roof (RF 639)