

Swirl jet diffuser**11051032**
AR 883 THERMO D315 RAL9003-30%

The AR 883 Thermo is a high-induction swirl jet diffuser for air diffusion in commercial buildings with high ceilings.



AR 883 THERMO D315 RAL9010-85%

PRODUCT BENEFITS

- ideal for large systems with high mixing rates,
- automatic adjustment of diffuser size according to temperature needs, for excellent comfort management in all seasons,
- no electrical connections required.

Principles of operation

The AR 883 Thermo diffuser is installed in the ceiling using an LRE plenum. It offers an adjustable swirl jet diffusion for air conditioning systems handling large temperature differences and high-ceiling rooms.

Product description

The AR 883 Thermo is a high-induction swirl jet diffuser for air diffusion in ventilation or air conditioning systems in commercial buildings with high ceilings. It is ideal for systems handling large temperature differences, due to its high mixing capacity. The movement of the adjustable vanes is automatic and rapid, according to the temperature of the supply air, for optimal operation in all seasons. It features an epoxy coating RAL 9010 white 85% finish.

Fields of application

Non-residential buildings

Installation

The AR 883 Thermo diffuser is installed in the ceiling using an LRE plenum. The diffuser is attached to the LRE plenum using a concealed screw in the neck.

Reference arguments

- AR 883 adjustable swirl jet diffuser for high ceilings.
- D315 protection rating
- Aluminium body and vanes with epoxy coating RAL 9003 white 30% (other colours available).
- A thermal spring adapts the vane angle according to the temperature for automatic transition between summer and winter modes (summer and winter vane angles determined by screw on installation).
- Concealed screw attachment.
- Accessory: connection plenum.

Main characteristics

- adjustable swirl jet diffuser,
- high mixing capacity for rapid homogenisation of temperatures,
- ideal for air conditioning systems handling large temperature differences,
- installed on ceiling,
- aluminium body and vanes,
- concealed screw attachment to plenum on diffuser neck,
- nickel-titanium alloy thermally-sensitive spring to automatically switch van angle according to the temperature of the supply air,
- "winter" position (heating) to de-stratify the hot air,
- "summer" position (cooling) for perfect control of air speeds in occupied areas,
- "winter» and "summer" angles can be adjusted by screw at time of installation,
- available in diameters 250 to 630 mm,
- aluminium with epoxy coating RAL 9010 white.

Supplementary characteristics

- accessories:
- galvanised steel LRE connection plenum with side branch connection.

Accessories

| Désignations | References |
|---|------------|
| PLENUM LRE842/883 FO D315/315 | 11053314 |
| LRE Plenum diff circular FO D315 PC cfg | 11053349 |
| LRE plenum insul diff circular 5 sides FO D315 PC cfg | 11053369 |

Swirl jet diffuser

11051032

AR 883 THERMO D315 RAL9003-30%

Dimensional data

| References | C (mm) | G (mm) | H1 (mm) | H2 (mm) | Ø A (mm) | Ø D (mm) |
|------------|--------|--------|---------|---------|----------|----------|
| 11051032 | 375 | 50 | 365 | 20 | 500 | 315 |

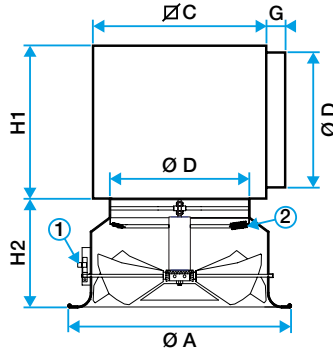

AR 883 Thermo diffuser with LRE plenum

Airflow data

| References | Comfort airflow for Lw 40 dB(A) (m³/h) |
|------------|--|
| 11051032 | 1000 |