

11090645

Axone Micro III 1-speed/Smoke exhaust - 3-phase 400V - Progressive start -100A

AXONE Micro III 1SP/DES D.PROG is a pre-wired, NF-certified safety box used to control smoke and heat exhaust fans.



AXONE box Progressive start 1 Speed (25.4 A, 43.3 A) Size 1

PRODUCT BENEFITS

- power gain control on AES,
- $I_d/I_n < 3$,
- inexpensive to install.
- Stores and displays the last 5 faults.

Principles of operation

When instructed by the FACP, AXONE Micro III 1SP/DES D.PROG activates the fan progressively in smoke and heat exhaust mode. When instructed by the Fire service shutdown control, it stops the fan and sets it to “default” mode. Then, using the reset control, it changes to “standby” mode.

Product description

AXONE Micro III 1SP/DES D.PROG is an NF-certified safety box used to control smoke and heat exhaust fans in non-residential buildings and industrial premises. Connected to the FACP between the main LV distribution board and the fan, it manages any faults with front panel display, stores the last five faults, activates the fan on instruction by the FACP, stops the fan and sets it to standby mode.

AXONE Micro III 1SP/D.PROG provides a single fan speed for smoke and heat exhaust.

Fields of application

New, Refurbishment, Non-residential buildings

Installation

- adjust starter according to the rated motor current in relation to the maximum starter current,
- install the safety box near the main LV distribution board or near the fan unit.
- attach the box to the floor or the wall, preferably using the recommended flat roof base,
- outdoors, use the flat roof base,
- use the wall attachment brackets if the flat roof base is attached to a wall,

Reference arguments

- Cover on hinges
- Smoke exhaust push button on front panel.
- 2 mini push-buttons on the PCB to perform a full cycle: simulated fire service shutdown order and simulated reset order.
- Fitted with a progressive starter. Progressive start-up is done automatically.
- Storage and display of last five faults on front panel.

11090645

Axone Micro III 1-speed/Smoke exhaust - 3-phase 400V - Progressive start -100A

Main characteristics

- NF certified,
- IP54 certified by an independent lab,
- smoke and heat exhaust only,
- progressive starter,
- for 1-speed 3-phase 400 V motor with search for power limitation of AES,
- clear display of state and possible fault on front panel, without opening the box,
- hinged cover,
- Smoke and heat exhaust button on front panel,
- 2 mini-push buttons inside the box to perform a full cycle:
 - simulates a Fire service shutdown order,
 - simulates a reset order.
- insulation check on line "downstream" of box, factory setting 500 k,
- "upstream" phase check: check phases are present and not inverted,
- stores condition of box in case of power outage: box resumes initial state on return of power,
- standard NF-S 61.933 recommends quarterly inspection of safety boxes.
- storage and display of last five faults.

Supplementary characteristics

- Clear display of state and possible fault on front panel, without opening the box.
- 2 mini-push buttons inside the box to perform a full cycle:
 - simulates a fire service shutdown order
 - simulates a reset order,
- Stores and displays the last 5 faults.

General data

References	Size
11090645	T2

Dimensional data

References	H (mm)	L (mm)	P (mm)
11090645	700	500	300

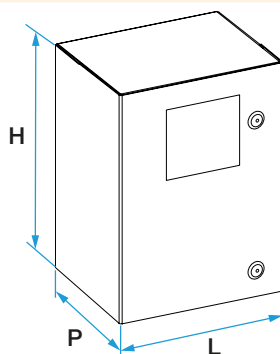

Electrical datas

References	Rated current (A)
11090645	100

11090645

Axone Micro III 1-speed/Smoke exhaust - 3-phase 400V - Progressive start -100A

Principe de fonctionnement

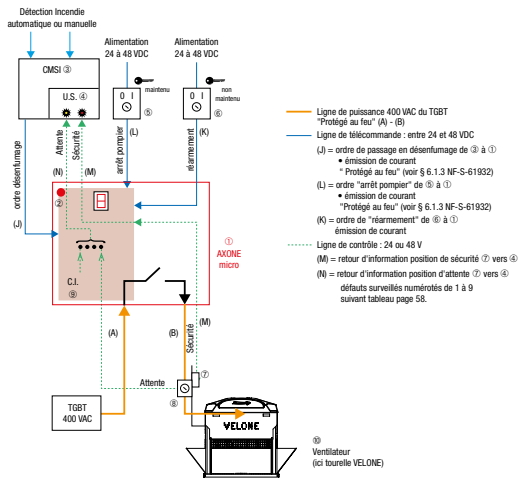

Schematic drawing of a system featuring a 1-speed smoke and heat exhaust box fan with progressive start.