

# 11015070

## C31 BAHIA® CURVE L 10-50/75 m<sup>3</sup>/h - Ø 125 mm pull cord - White

The BAHIA CURVE L humidity-controlled terminal for kitchens ensures sufficient and constant extraction of indoor pollution according to the humidity level in the room.



BOUCHE C31 BAHIA Ø 125 mm cordelette

### PRODUCT BENEFITS

- Unique no-grille design conserves the aesthetic character of the terminal even if it is clogged,
- easy to install,
- simple to clean.

### REGLEMENTATIONS AND COMPLIANCES

Identification no. QB37 : 05/02-CHY3-2266;05/02-CHY3-2267  
 Technical Opinion no. : 14.5/17-2267;14.5/17-2266

### Principles of operation

In a humidity-controlled CMEV system, the airflow is automatically controlled according to the humidity level in rooms and therefore based on the actual ventilation needs of the building. The BAHIA CURVE L terminal is installed in kitchens.

### Product description

BAHIA CURVE L is a humidity-controlled extract terminal designed for kitchens in individual houses, new and refurbished multi-occupancy residential housing. This terminal is the large model for airflow needs • 50 m<sup>3</sup>/h.

### Fields of application

Multi-occupancy residential housing, Individual residential housing, New, Refurbishment

11015070

C31 BAHIA® CURVE L 10-50/75 m<sup>3</sup>/h - Ø 125 mm pull cord - White**Installation**

- BAHIA CURVE L must be installed in a kitchen,
- the terminal must be located at the top of a vertical wall or on the ceiling at least 1.80 m from the floor,
- the terminal must be accessible and removable with a distance of at least 20 cm between the centre of the terminal and the adjacent walls and not glued to the duct,
- the air tightness of the terminal - duct connection must be optimal. This is achieved with O-ring seals and reinforced with a sleeve. A sheet metal sleeve is used for multi-occupancy housing (stainless steel sleeve required for a gas CMEV system). A plastic sleeve may be used for an individual house. The sleeves are slotted directly into: - a semi-rigid or rigid duct Ø 125 mm correctly shaped, a sheet metal sleeve Ø 125 mm (code 11012220),
- the terminal is slotted directly into: a sleeve, RT Flex, rigid or semi-rigid ducts. The airtight seal is created with O-ring seals and reinforced with a sleeve,
- versions with shaft D 80 mm, slots into sleeves, rigid and semi-rigid ducts,
- shaftless versions: clipped on ØD 125 mm shaft (Roll-In seal), Ø 116mm shaft (Roll-In seal) or Ø 100 mm shaft (foam seal),
- It is advisable to fix kitchen humidity-controlled terminals in place using two Ø 3.5 x 35 mm screws with Ø 6 x 35 mm plugs to prevent them from turning when boost setting is used.
- If cord-operated grilles are installed in the ceiling or above a piece of furniture, use a cord return system (code 11015001).
- Note: For humidity-controlled terminals with electrical controls, a 9V alkaline battery type 6LR61 is required as well as a conventional push button (code 11026011),
- Humidity-controlled terminals operate within the 80-160 Pa pressure range,
- Extract terminals must be maintained and checked at least once a year. Never connect a mechanical extractor hood to the CMEV network (article 14 of Decision of 24 March 1982),
- Before replacing an old terminal with a new one, measure the pressure and identify the type of dwelling,

**Reference arguments**

## Application:

- Humidity-controlled extract terminal for kitchen,
- Specially designed for multi-occupancy housing (new and refurbishments).

## Description:

- Attachment D125 mm,
- Base airflow: 10/50 m<sup>3</sup>/h, boost airflow 75 m<sup>3</sup>/h,
- Relative humidity: 50/90%,
- Pressure range: 80 to 160 Pa,
- Controls: pull cord
- White colour,
- Roll-In seal,
- Easy to install.

## 11015070 C31 BAHIA® CURVE L 10-50/75 m<sup>3</sup>/h - Ø 125 mm pull cord - White

### Main characteristics

- Humidity-controlled terminal, large size (airflow • 50 m<sup>3</sup>/h),
- versions and accessories to meet all installation needs,
- easy maintenance: control sub-assembly quick to clip on and unclip, easy to clean without being removed from the wall thanks to its removable Bahia Curve casing.
- pressure range: 80 - 160 Pa.

### Accessories

Désignations	References
Pull cord return for ceiling installation	11015001
Acoustic ring for terminals Ø 125 mm	11019429
Shoulder sleeve Ø 125 mm	11012220
Sheet sleeve 3 tabs Ø 125 mm	11012252
Male sleeve Ø 124 mm	11012250
TRIDENT SHEET SLEEVE D125 H300	11022055
Lock washer Ø 125 mm	11087043
Stapled renovation plate for Bap'SI and Bahia Curve - White	11019050
Screw-on renovation plate for Bap'SI and Bahia Curve - White	11019054

### General data

References	Type of dwelling in Hygro B	Type of control	Type of dwelling	Colour
11015070	Hygro B;Hygro A	Pull cord	F1	Lagoon blue

### Dimensional data

References	H (mm)	L (mm)	Ø connection (mm)
11015070	230	48,8	Sans fût

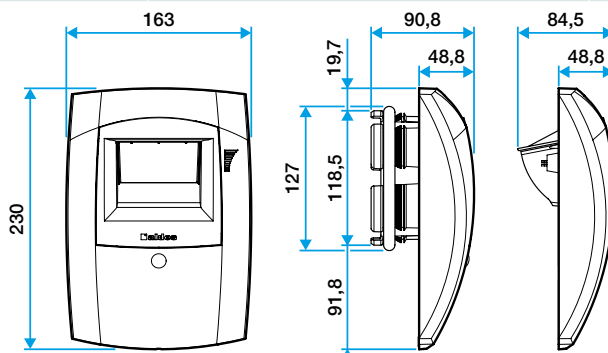

Bahia Curve L

### Airflow data

References	Basic airflow (m <sup>3</sup> /h)	Boost airflow (m <sup>3</sup> /h)	Relative humidity (%)	Pressure range (Pa)
11015070	10-50	75	50/90	80-160

### Installation visual 1

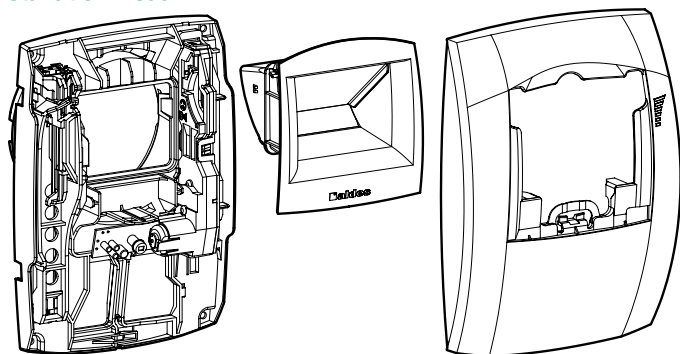

Mise en œuvre Bahia Curve L

11015070

C31 BAHIA® CURVE L 10-50/75 m<sup>3</sup>/h - Ø 125 mm pull cord - White