

11060823

DFE® Micro-watt 1200 G4 no RC

DFE® Micro-Watt is a affordable compact counterflow unit for small rooms, that deliver good indoor air and have a simple automatic.



DFE Remote control

PRODUCT BENEFITS

- High-efficiency heat exchanger
- ready to use,
- motorised by-pass for free-cooling.

Principles of operation

DFE Micro-Watt brings fresh, filtered air into the building and recovers heat from exhaust air using its high-efficiency heat exchanger. The incoming air can be heated and/or cooled using a comprehensive range of coils.

Product description

DFE Micro-Watt is a compact counterflow air handling unit, with horizontal duct connections. The unit is delivered ready to use with a highly intuitive control and configuration interface.

Fields of application

New, Refurbishment, Non-residential buildings

Installation

Air handling for energy-efficient non-residential buildings.

Reference arguments

- 4 DFE models up to 1,200 m³/h.
- «Plug & Play» pre-cabled monobloc unit.
- Anodised extruded aluminium profile box frame.
- 15 mm twin-skin panels. Galvanised steel DFE interior.
- Mineral wool thermal insulation.
- Very high-efficiency counterflow heat exchanger (up to 96%).
- Centrifugal fans with electronically commutated motors.
- Comprehensive controls with remote control: - Constant airflow (CA), - Constant pressure (CPs), - 0-10V signal (LS). - Constant torque (TQ)
- Motorised bypass enabling free-cooling.
- M5 pleated flat filters (option: F7 for fresh air).
- Proximity switch.
- galvanised steel condensate collection tray.
- Internal clock.
- Configurable via hard-wired RC, GRC or touchscreen controller (optional accessories)
- Communication via ModBus RTU (option via SATModBus) / KNX / Ethernet / WiFi

11060823

DFE® Micro-watt 1200 G4 no RC

Main characteristics

- plug & Play pre-cabled monoblock unit,
- casing structure made of extruded and anodized aluminum,
- 15 mm double wall panels. DFE interior in galvanised steel,
- polystyrene thermal insulation (M1 fire rating),
- high efficiency counterflow heat exchanger. EUROVENT AAHE certified,
- centrifugal fans with EC motors,
- full controls via remote control unit:
 - constant airflow (CA),
 - constant pressure (CPs),
 - 0-10V signal (LS).
- motorised bypass (70% on/off) enabling free-cooling,
- ISO Coarse 65% (G4) flat and pleated filters (optional ISO ePM1 55% (F7) on fresh air),
- proximity switch,
- integrated clock,
- galvanised steel condensate collection tray,
- Modbus RTU (option via SATModbus),
- configuration via RC with SATModbus relay, or GRC (optional accessories).

Accessories

Désignations	References
Pressure sensor kit DFE	11058050
Relay SAT3	11058149
VEX KIT DFE 1200	11058180
Adapter part for DFE 1200 (fresh air/extract) 338x798 Ø 355 mm	11058188
SAT Modbus relay	11058442
SAT external coil kit	11058443
SAT Wifi DFE TAC 4/5	11060846
SAT ethernet DFE TAC 4/5	11060847
Tactile remote control for DFE Tactouch	11069101
Flexible connector - Ø 200	11096934
Flexible connector - Ø 250	11096935
Flexible connector - Ø 315	11096936
Flexible connector - Ø 355	11096937
MS Pro M0 Ø355 mm	11094695
Sens CO2 sensor	11017090
Motor Sfa-S2 On/Off 24/230V	11055045
Standalone detector trip device 230/24V	11906103
Smoke sensor	11058417
Temperature sensors x3 kit for DFE/DFE+	11058091
MS PRO V2 D200	11094296
MS PRO V2 D250	11094297
MS PRO V2 D315	11094298
MS PRO V2 D355	11094299

Consumables

Désignations	References
G4 filter kit DFE 1200	11058167
F7 filter kit DFE 1200	11100233
	11101511

Associated services

Commissioning

General data

References	Thickness of insulation (mm)	Available filters	Connection direction	Type of exchanger	Type of motor	Type of impeller
11060823	15	ISO Coarse 65% (G4), optional ISO ePM1 55% (F7)	Horizontal	With plates	EC	Forward curve

11060823 DFE® Micro-watt 1200 G4 no RC

Dimensional data

References	A (mm)	B (mm)	C (mm)	Ø connection (fresh air or exhaust) (mm)	Ø connection (discharge or air supply) (mm)	Weight (kg)
11060823	860	860	1000	355	355	173

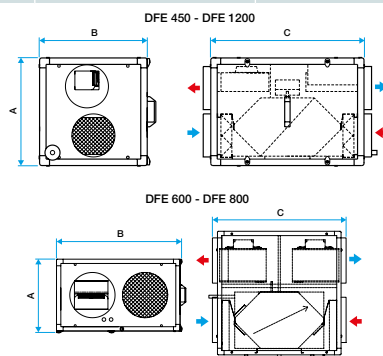

Dimensions DFE micro-watt

Airflow data

References	Max. airflow (m³/h)
11060823	1260

Thermal data

References	Max. exchanger output (%)
11060823	90

Electrical datas

References	Max. electrical output of unit (kW)	Unit voltage (V)
11060823	2 x 0,42	230

Installation visual 1

DFE-MW_Installation_001.eps

Curve

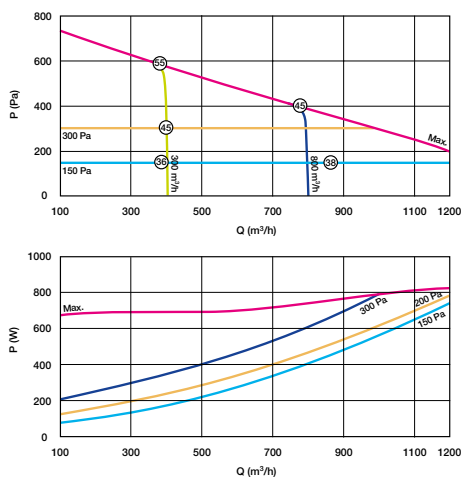

- > Aeraulic curve as per standard NF EN ISO 5801
- > : Lp in dB(A) = total sound pressure level measured at 4 m from the box fan, free discharge
- > P (Pa) = static pressure

Caractéristiques aérauliques et acoustiques DFE 1200 micro-watt