

Fixed ventilation grille**11023941****Deflector for supply air terminal**

BIP and BIO and fixed ventilation grilles for individual houses and multi-occupancy housing.



BIP D 80 and D 125 mm grille

PRODUCT BENEFITS

- aesthetic BIO Design terminal, fully dirigible,
- RAL 9010 white finish,
- range available in 3 diameters.

Principles of operation

BIP and BIO and fixed ventilation grilles for individual houses and multi-occupancy housing. Available in different diameters and operates on air exhaust (BIP) and supply (BIP and BIO).

Product description

BIP and BIO fixed ventilation grilles are designed for individual houses as well as new and refurbished multi-occupancy housing. They operate on both air supply and exhaust.

Fields of application

Multi-occupancy residential housing, Individual residential housing, New, Refurbishment

Installation

0

Reference arguments

Application

- Full range of accessories for exhaust and heat recovery ventilation system in individual house or multi-occupancy residence
- New builds or refurbishment

Description

- Deflector Bio Design supply air terminal

Fixed ventilation grille

11023941

Deflector for supply air terminal

Main characteristics

- BIP and BIO fixed ventilation grilles,
- air supply and exhaust,
- available in 3 diameters: 80 mm, Ø 80 mm and Ø 125 mm,
- Ø 80 offers airflow of 60 m³/h,
- Ø 100 offers airflow of 90 m³/h,
- Ø 125 offers airflow of 110 m³/h,
- easy to maintain.

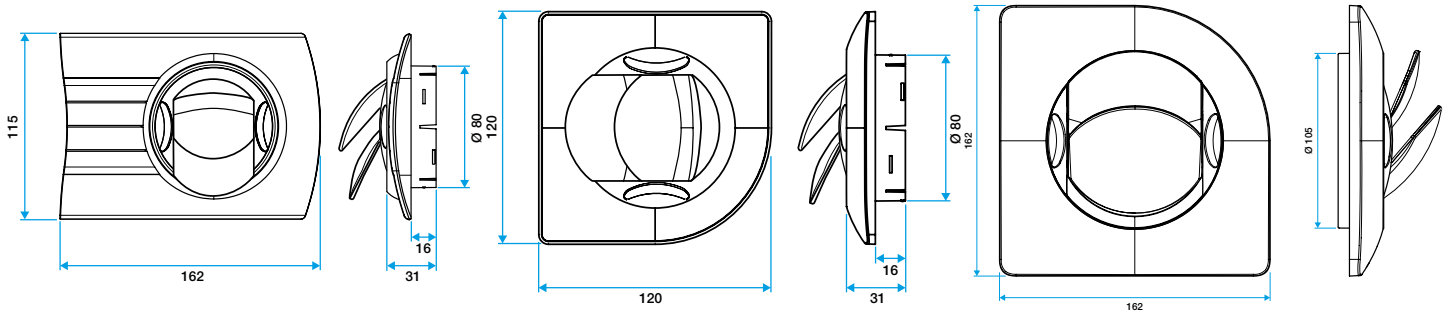

Grille BIO Design rectangulaire D 80 mm

Grille BIO Design carré D 80 mm

Grille BIO Design carré D 125 mm

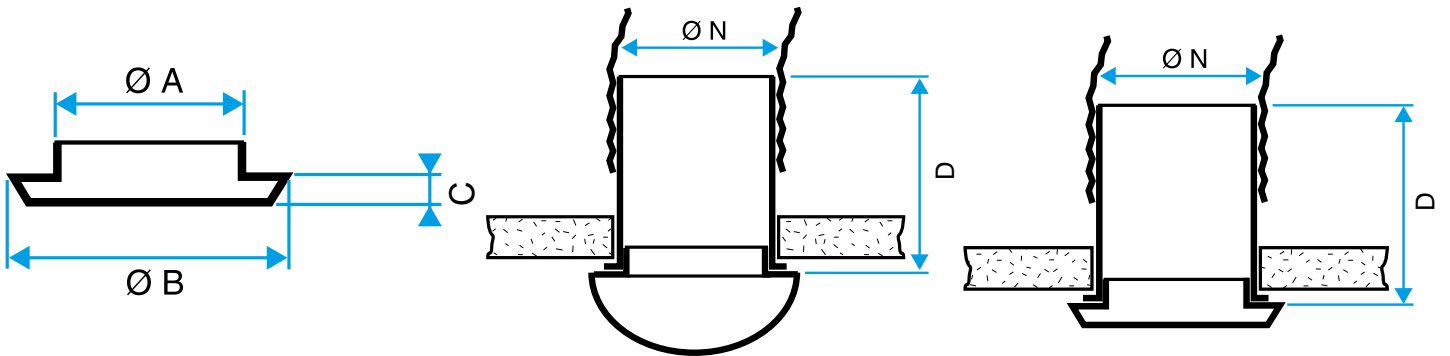

BIP / BIO terminal only

BIO terminal with sleeve

Bouche BIP avec manchette