

11011507 EAIO M22 WHT

EAIO is an acoustic self-balanced air inlet for installation in woodwork on individual houses and multi-occupancy residential buildings.



EAIO BLC/WHI

PRODUCT BENEFITS

- accessory-free soundproofing up to 38 dB,
- no visible screw attachment.

Principles of operation

EAIO is a self-balanced air inlet. It ensures a constant airflow of fresh air, whatever the conditions inside the dwelling.

Product description

EAIO is an acoustic self-balanced air inlet for installation in woodwork on individual houses and multi-occupancy residential buildings. It ensures a constant airflow of fresh air, whatever the conditions inside the dwelling.

Fields of application

Multi-occupancy residential housing, Individual residential housing, Refurbishment

Installation

- The air inlets should only be installed in main rooms: bedroom, living room, lounge,
- they must be installed in the upper part of windows or on the roller shutter box,
- the airflow must be directed at the ceiling,
- installed on woodwork,
- installed on any type of mortise,
- single slot 250 x 15 mm.

Main characteristics

- acoustic air inlet for woodwork,
- installed in:
- single-slot mortise 250 x 15 mm.

11011507 EAIO M22 WHT

Dimensional data

References	w (mm)	L (mm)
11011507	43	390

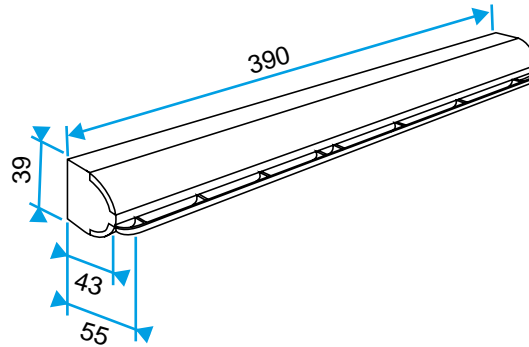

Entraxe : 370 mm

Installation visual 1

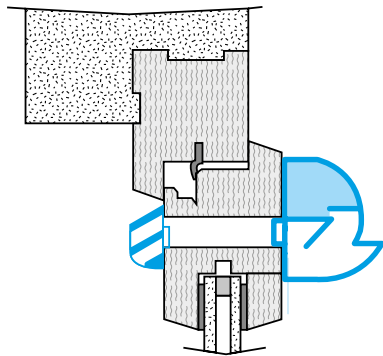

Mise en œuvre entrée d'air EAI