

11011506

EAO 2 POSITIONS M22 V01 WHT

EAO is an acoustic self-balanced air inlet for installation in woodwork on individual houses and multi-occupancy residential buildings.



EAO

PRODUCT BENEFITS

- soundproofing up to 41 dB,
- Hygro A compatible for NF certified versions,
- no visible screw attachment.

Principles of operation

EAO is a self-balanced air inlet. It ensures a constant airflow of fresh air, whatever the conditions inside the dwelling.

Product description

EAO is an acoustic self-balanced air inlet for installation in woodwork on individual houses and multi-occupancy residential buildings. It ensures a constant airflow of fresh air, whatever the conditions inside the dwelling. Hygro A-compatible for NF-certified versions.

Fields of application

Multi-occupancy residential housing, Individual residential housing, Refurbishment

Installation

- air inlets must only be mounted in the main rooms of the dwelling: bedrooms, living room, lounge, etc.
- they must be installed inside dwellings, in the upper part of windows or on the vertical panel of a roller shutter box,
- the incoming airflow must be oriented towards the ceiling,
- can be installed on any type of mortise:
 - double slot 2 x (172 x 12) mm or
 - single slot 250 x 15 mm.

Main characteristics

- self-balanced acoustic air inlet,
- for installation on joinery,
- exists in different colours.

11011506 EAO 2 POSITIONS M22 V01 WHT

Dimensional data

References	H (mm)	w (mm)	L (mm)
11011506	39	43	390

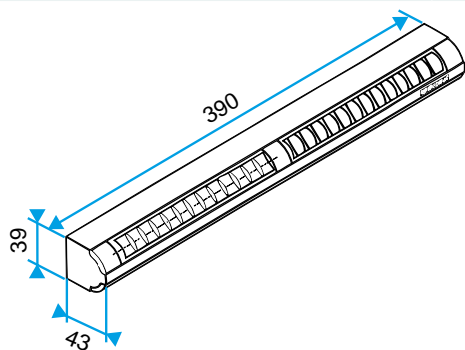

EA22, EA30; Entraxe = 370 mm

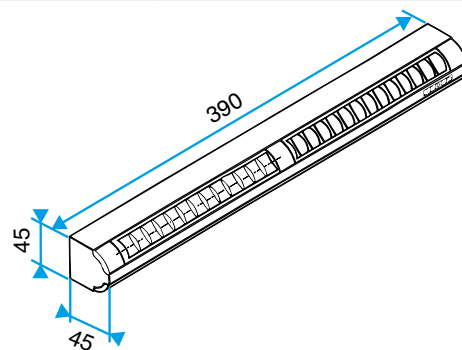

EA45; Entraxe = 370 mm

Installation visual 1

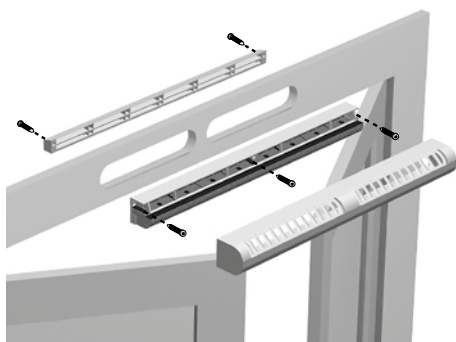

Mise en œuvre entrée d'air EA

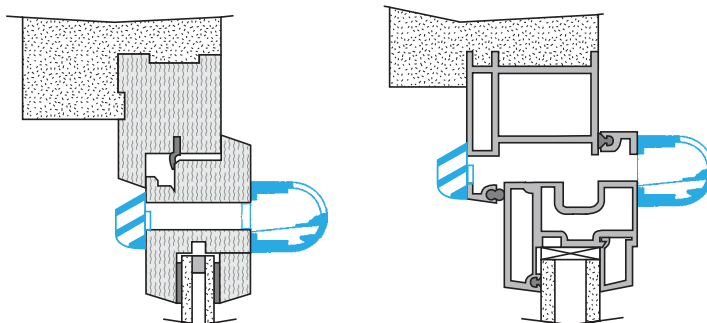

Coupe entrée d'air EA