

11011012

EAT 250 m³/h - Length 1500 mm

EAT-SAT is a unidirectional acoustic fan unit for multi-occupancy residential and non-residential buildings (classrooms, meeting rooms, multi-function rooms, gyms, community hall, etc.).

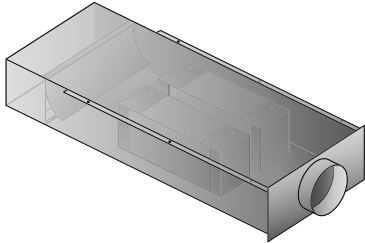

EAT

PRODUCT BENEFITS

- airflow of 250 m³/h at 20 Pa,
- very good insulation against outdoor noise,
- very good insulation against indoor noise.

Principles of operation

The EAT-SAT is a unidirectional acoustic box fan. The box fan enables air supply or exhaust in association with a unidirectional mechanical ventilation system.

Product description

EAT/SAT is a soundproofed unit for air inlets or outlets and is associated with an exhaust or air supply CMEV system.

EAT: the supply air ventilation system. The EAT brings in new air to match the airflow extracted (from 18 to 25 m³/h per person).

- High inward airflow (corresponds to around 9 conventional air inlets).
- Outside noise is attenuated by the soundproofing elements.
- An air inlet that respects acoustic regulations.

SAT: the exhaust air ventilation system. The SAT serves to evacuate soiled air.

- Incoming air can be filtered, pre-heated,
- Exhaust air is discharged on the outside wall or into discharge ducts via the SAT.
- Outlet outdoors or into discharge duct: outdoor noise is attenuated by the soundproofing elements.

Fields of application

Multi-occupancy residential housing, New, Refurbishment, Non-residential buildings

Installation

EAT-SAT is suspended from the ceiling using brackets (supplied) and rods (not supplied). It can be installed in the suspended ceiling (min. effective height: 250 mm).

Reference arguments

- EAT/SAT is a soundproofed unit for air inlets or outlets and is associated to a CMEV exhaust or air supply system. EAT: the exhaust air ventilation system. The EAT brings in new air to match the airflow extracted (from 18 to 25 m³/h per person).
- High inward airflow (corresponds to around 9 conventional air inlets).
- Outside noise is attenuated by the soundproofing elements.
- An air inlet that respects acoustic regulations. SAT: the air supply ventilation system. The SAT serves to evacuate soiled air.
- Incoming air can be filtered, pre-heated,
- Exhaust air is discharged on the outside wall or into discharge ducts via the SAT.
- Outlet outdoors or into discharge duct: outdoor noise is attenuated by the soundproofing elements.

11011012 EAT 250 m³/h - Length 1500 mm

Main characteristics

- acoustic fan unit comprising:
 - a galvanised steel unit with expansion box,
 - calibrated non-return damper,
 - melamine sound attenuator.
- the airflow is calibrated at 250 m³/h at 20 Pa.

Accessories

Désignations	References
SF704R TP F16 D200 White Ax600x600	11051087
A842 TP D200 AXB 600X600 RAL9010-30%	11051372
RT plenum F0 225X225 D160	11053583
AWA251 500X200	11052035
Adapter F4 500X200	11053772
RT square plenum 225x225 D160 PA cfg	11053523

General data

References	Main material	Colour
11011012	Galvanised steel	Galvanised steel

Dimensional data

References	H (mm)	L (mm)	P (mm)	Ø (mm)
11011012	242	542	1500	200

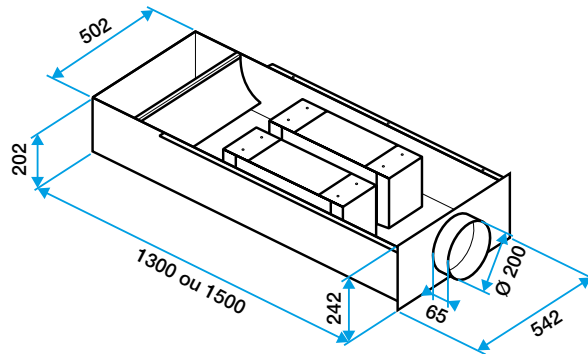

EAT

Airflow data

References	Airflow (m ³ /h)
11011012	250

Acoustic data

References	D _{new} (C) (dB)	D _{new} (dB)
11011012	49	44

Installation visual 1

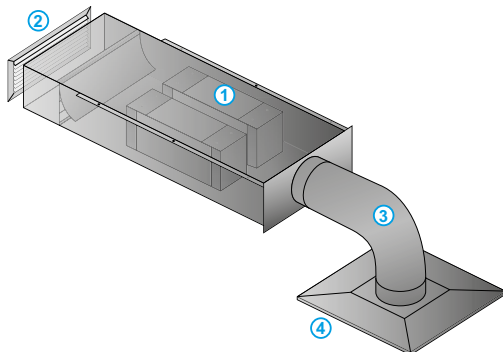

Sketch of full assembly EAT/SAT

11011012

EAT 250 m³/h - Length 1500 mm

Curve

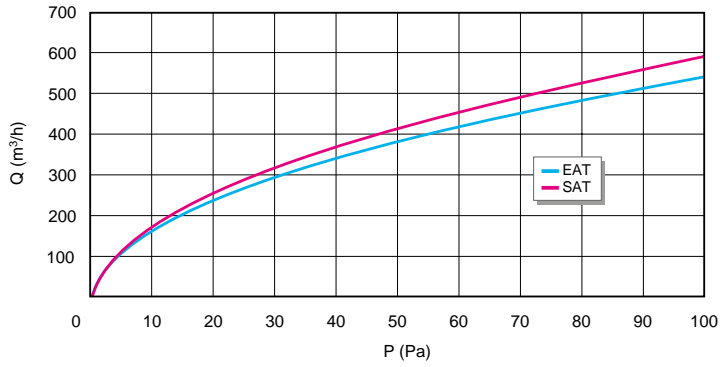

Air curves EAT/SAT