

# 11094628

## ECTA 200 L>2000 or H>2000 or L>1200 and H>1200

The ECTA 200 rectangular sound attenuator strongly attenuates low, mid and high-frequency acoustic propagation in rectangular ducting.



ECTA 200

### PRODUCT BENEFITS

- high-performance acoustic attenuation,
- energy savings: low pressure losses,
- fully configurable: dimensions, number of baffles, type of frame, etc.

### Principles of operation

The ECTA 200 comprises a single-piece panel made of 200 mm thick mineral wool which absorbs noise. To maximise attenuation, several should be installed in series inside a ducting element.

### Product description

The ECTA 200 rectangular sound attenuator strongly attenuates noise transmitted in the ventilation ducting and therefore ensures acoustic comfort inside non-residential and multi-occupancy residential buildings. The baffle is 200 mm thick and its L x H dimensions may be between 300 and 2400 mm.

### Fields of application

Multi-occupancy residential housing, New, Refurbishment, Non-residential buildings

### Installation

- installed in series in a rectangular ducting element,
- install between slides for better performance management,
- Delivered as complete unit (on request).

### Main characteristics

- thickness 200 mm,
- dimensions (L and H) from 300 to 2400 mm.
- solid mineral wool panels,
- density: 40 kg/m<sup>3</sup>,
- black anti-flocking glass mat, 1 mm thick in standard range (available on request: glass fibre for sterile rooms or perforated plate for high pressure and speed applications),
- galvanised steel frame, standard thickness 6/10° (available on request: 304 or 316L stainless steel),
- Available on request: complete unit including the housing, riveted baffles and METU type connection frame,
- M0 fire certification, or A1 under Euroclass ratings,
- version tested to 400°C - 2 hours on request.
- Class B air tight properties as per EN 1751 (class C on request).

# 11094628

## ECTA 200 L>2000 or H>2000 or L>1200 and H>1200

### General data

References	Insulation density of the baffle (kg/m <sup>3</sup> )	Insulation thickness of the baffle (mm)
11094628	40	100

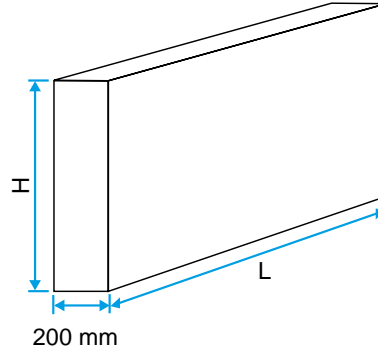

ECTA 200