

# 11014119

## EFT 30

EHT is a humidity-controlled air inlet for wall penetrations in single-family dwellings and multi-occupancy buildings.



EHT/EFT² humidity-controlled air inlet

### PRODUCT BENEFITS

- simple to install,
- high acoustic performance levels
- no visible fastening screws.

### REGLEMENTATIONS AND COMPLIANCES

Identification no. QB37 : 05/02-CHY1-2267; 05/02-CHY1-2266; 05/02-CHY2-2185  
 Technical Opinion no. : 14.5/17-2266; 14.5/17-2267

### Principles of operation

EHT is a sound-proofed humidity-controlled air inlet for wall penetrations in single-family dwellings and multi-occupancy buildings.

### Product description

EHT delivers fresh air and distributes incoming airflow around the dwelling according to the humidity level.

### Fields of application

Multi-occupancy residential housing, Individual residential housing, New, Refurbishment

### Installation

- The EHT must be installed in a wall penetration,
- EHT is installed on a circular sleeve,
- 100 mm or 125 mm diameter connection to Bath/shower PVC pipe

### Main characteristics

- sound-proofed humidity-controlled or fixed air inlet.
- installed in wall penetration
- EHT accessories available to improve acoustic performance

## 11014119 EFT 30

### Supplementary characteristics

This product is also available as a fixed air inlet under the name EFT.

### Accessories

Désignations	References
Tube Ø 100mm, L350mm	11014121
Sound-proofing foam for outdoor hood	11014123
EHT shaft / PVC Ø 125	11014126
Tube Ø 100mm, L500mm	11014128
Flow limiter D100 mm for EHT, EFT air inlet	11014145
Adapter for airflow limiter D125 mm for EHT <sup>2</sup> and EFT <sup>2</sup> air inlet	11014146
Acoustic foam D100	11014124
External rainhood	11014122
Acoustic foam D125	11014125
Anti-insect filter	11014147

### Consumables

Désignations	References
Tube Ø 100mm, L350mm	11014121
Outdoor hood	11014261
Sound-proofing foam for outdoor hood	11014123
Acoustic foam D100	11014124
Acoustic foam D125	11014125
EHT shaft / PVC Ø 125	11014126
Tube Ø 100mm, L500mm	11014128
Flow limiter D100 mm for EHT, EFT air inlet	11014145
Adapter for airflow limiter D125 mm for EHT <sup>2</sup> and EFT <sup>2</sup> air inlet	11014146
Anti-insect filter	11014147

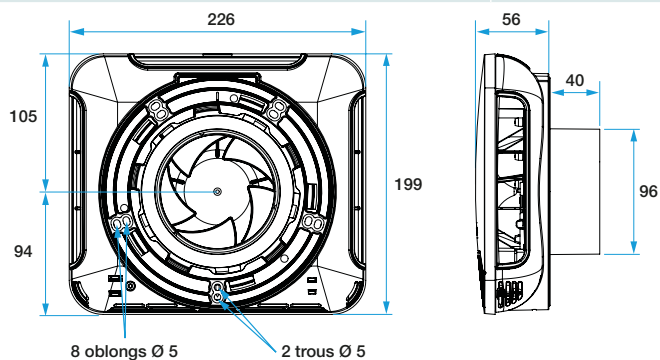

Encombrement Entrée d'air EHT2 et EFT2

Encombrement Auvent EHT2 et EFT2

### Airflow data

References	Airflow (m <sup>3</sup> /h)
11014119	30