

11014116

EHT 6-44

EHT is a humidity-controlled air inlet for wall penetrations in single-family dwellings and multi-occupancy buildings.



EHT/EFT² humidity-controlled air inlet

PRODUCT BENEFITS

- simple to install,
- high acoustic performance levels
- no visible fastening screws.

REGLEMENTATIONS AND COMPLIANCES

Identification no. QB37 : 05/02-CHY1-2267; 05/02-CHY1-2266; 05/02-CHY2-2185
 Technical Opinion no. : 14.5/17-2266; 14.5/17-2267

Principles of operation

EHT is a sound-proofed humidity-controlled air inlet for wall penetrations in single-family dwellings and multi-occupancy buildings.

Product description

EHT delivers fresh air and distributes incoming airflow around the dwelling according to the humidity level.

Fields of application

Multi-occupancy residential housing, Individual residential housing, New, Refurbishment

Installation

- The EHT must be installed in a wall penetration,
- EHT is installed on a circular sleeve,
- 100 mm or 125 mm diameter connection to Bath/shower PVC pipe

Main characteristics

- sound-proofed humidity-controlled or fixed air inlet.
- installed in wall penetration
- EHT accessories available to improve acoustic performance

11014116 EHT 6-44

Supplementary characteristics

This product is also available as a fixed air inlet under the name EFT.

Accessories

Désignations	References
Tube Ø 100mm, L350mm	11014121
Sound-proofing foam for outdoor hood	11014123
EHT shaft / PVC Ø 125	11014126
Tube Ø 100mm, L500mm	11014128
Flow limiter D100 mm for EHT, EFT air inlet	11014145
Adapter for airflow limiter D125 mm for EHT ² and EFT ² air inlet	11014146
External rainhood	11014122
Acoustic foam D100	11014124
Acoustic foam D125	11014125
Anti-insect filter	11014147

Consumables

Désignations	References
Tube Ø 100mm, L350mm	11014121
Sound-proofing foam for outdoor hood	11014123
Acoustic foam D100	11014124
Acoustic foam D125	11014125
EHT shaft / PVC Ø 125	11014126
Tube Ø 100mm, L500mm	11014128
Flow limiter D100 mm for EHT, EFT air inlet	11014145
Adapter for airflow limiter D125 mm for EHT ² and EFT ² air inlet	11014146
Anti-insect filter	11014147

General data

References	Colour
11014116	Lagoon blue

Dimensional data

References	H (mm)	w (mm)	L (mm)	Ø connection (mm)	DC_R_SECTION_(DATE) (cm ²)
11014116	145	240	56	100 ; 125	04-31

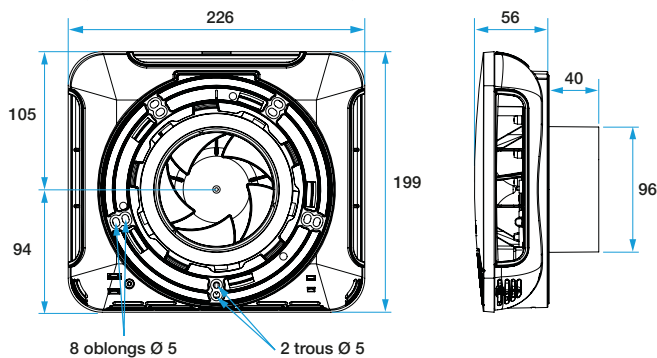

Encombrement Entrée d'air EHT2 et EFT2

Encombrement Auvent EHT2 et EFT2

Airflow data

References	Airflow range (m ³ /h)
11014116	6-44

11014116 EHT 6-44

Curve

