

11033061

EasyHOME PureAIR COMPACT Connect

EasyHOME PureAIR Premium & Connect renews and purifies the air inside your dwelling using VOC and H2O sensors and its 4 purification modes.



CONNECT unit



CONNECT unit top view

PRODUCT BENEFITS

- 4 multi-pollutant sensors to detect and remove volatile organic compounds (VOCs), CO2 and humidity,
- Connected solution offering 4 remote-controlled ventilation modes along with indoor and outdoor air quality monitoring,
- 77% recycled plastic.

REGLEMENTATIONS AND COMPLIANCES

Identification no. QB37 : NA
Technical Opinion no. : NA

Principles of operation

EasyHOME PureAIR Premium and purifies the air inside your dwelling. Using its air quality sensors, it detects VOC, CO2 and humidity. It also automatically and efficiently removes contaminated air from the dwelling using 4 different purification modes.

Product description

EasyHOME PureAIR COMPACT Premium and Connect is a ventilation solution that monitors the quality of the air you breathe 24h/24. It detects volatile organic compounds (VOC), CO2 and humidity, then automatically and efficiently removes contaminated air from the dwelling via one of its 4 ventilation modes.

The PureAIR COMPACT Premium and Connect unit is fitted with a very low consumption motor and 4 electronic multi-pollutant sensors: 1 central VOC / CO2 sensor located on the fan motor and 3 remote H2O sensors in the kitchen and bathroom connections.

When associated with AirFILTER air inlets fitted with a pollen filter, the PureAIR solution filters incoming air for optimal indoor air quality.

EasyHOME PureAIR COMPACT Premium and Connect is compatible with multiple ducting systems and can be installed with Optiflex semi-rigid ducts for an airtight and efficient system.

EasyHOME PureAIR COMPACT is ultra-flat, extra quiet, and suited to installation in the attic or in small spaces, for example in a suspended ceiling or equipment room.

Fields of application

Multi-occupancy residential housing, Individual residential housing, Refurbishment

Installation

- multi-position installation: wall, ceiling, floor, sloped surface,
- just 2 attachment screws: centreline 406 mm,
- built-in anti-vibration strips,
- quick-connect electrical terminal block,
- compatible with all types of ducting:
 - Algaine flexible ducts,
 - Optiflex semi-rigid ducts,
 - Minigaine rigid ducts,
 - ducting must be insulated outside of heated spaces.
- Algaine EasyCLIP accessories supplied: quick-fit connectors and collar clamps for simplified connection of flexible ducts on the unit,
- Optiflex EasyCLIP accessories available as optional extras.

11033061

EasyHOME PureAIR COMPACT Connect

Main characteristics

- COMPACT unit made of recyclable plastic,
- connections on unit for one kitchen and up to 4 Bath/shower rooms:
 - 1 x Ø 125 mm connection for kitchen,
 - 4 x Ø 80 mm connections for bathroom/WC,
 - 1 x Ø 160 mm outlet.
- installation symbols on the unit and accessories,
- exhaust airflows controlled according to pollutant concentration detected by the unit,
- 4 ventilation modes: HOLIDAY, AUTO, BOOST, GUEST,
- multi-speed EC motor,
- connectivity:
 - EasyHOME PureAir Connect supplied with AldesConnect® Box modem for real-time monitoring of indoor and outdoor air quality, remote control via AldesConnect® phone app,
 - EasyHOME PureAIR Premium can be connected later with the purchase of an AldesConnect® Box modem,
- kits supplied with 3 ColorLINE® ventilation grilles and 4 AirFILTER air inlets.

Supplementary characteristics

- 4 operating modes that can be controlled and programmed using the AldesConnect® app:
 - HOLIDAY mode*: minimum air renewal for prolonged periods of absence,
 - AUTO mode: day-to-day operating mode, continuously variable with automatic speed control according to the level of VOC and H2O pollutants detected,
 - BOOST mode for bathrooms and kitchen: automatic high speed when humidity levels rise in bathrooms or the kitchen,
 - GUEST mode*: maximum speed in case of high CO2 level due to high occupancy of dwelling,
- *HOLIDAY and GUEST modes accessible as optional extras on EasyHOME PureAIR Premium, by adding an AldesConnect® Box modem.

Contents of kits

- VOC/CO2 sensor;1
- humidity sensor;3
- calibrated hole for kitchen;1
- calibrated hole for bathroom;2
- calibrated hole for WC;2
- plug Ø 80 mm;2
- AldesConnect™ Box;1

Accessories

Désignations	References
Outlet adapter EasyHOME Ø160/125 mm	11026025
Collar + connector EasyCLIP Ø125 mm	11033010
Collar + connector EasyCLIP Ø80 mm	11033011
Connector EasyCLIP + collar Ø 160 mm	11033016
CMEV push button for BAHIA CURVE terminal	11026011
OPTIFLEX® EasyClip accessory kit for EasyHOME units	11091994

General data

References	Number of connections Ø 125 mm	Number of connections Ø 80 mm	Maximum number of bathrooms/ WC	Number of speeds	Type of motor
11033061	1	4	4	multi-speed	EC

11033061

EasyHOME PureAIR COMPACT Connect

Dimensional data

References	H (mm)	L (mm)	P (mm)	Ø discharge (mm)	Weight (kg)
11033061	187	459	460	160	3,9

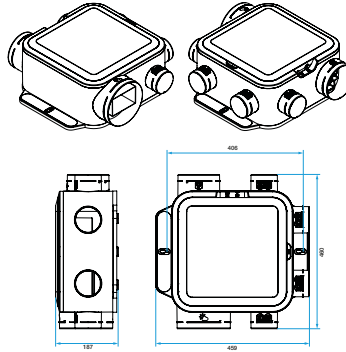

Encombrement en mm

Airflow data

References	Max. airflow ErP (m³/h)
11033061	400

Acoustic data

References	Sound pressure at 2 m from the kitchen terminal (dB(A))	Sound power at kitchen terminal (dB(A))	Sound power at the unit at 100 m³/h (dB(A))	Sound power ErP (dB(A))
11033061	21	26	30	44

Thermal data

References	Average daily consumption 2-bed dwelling (1 bathroom + 1 WC) (W)	Max. power in BOOST mode (W)
11033061	7	7

Electrical datas

References	Frequency (Hz)	Protection current (A)	Max. current (A)	Voltage (V)	Max. power
11033061	50	2	0,8	230	85

11033061 EasyHOME PureAIR COMPACT Connect

Regulatory data

References	Energy class ErP
11033061	B

Installation visual 1



Montage faux-plafond

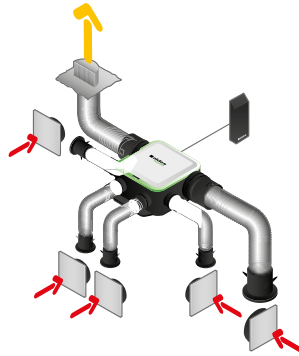

Installation avec conduits souples Algaire

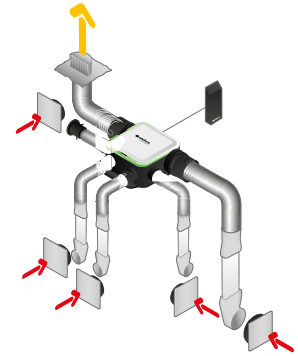

Installation avec conduits rigides Minigaine

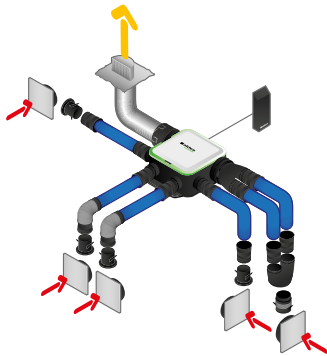

Installation avec conduits semi-rigides Optiflex



EasyCLIP Algaire

Principe de fonctionnement

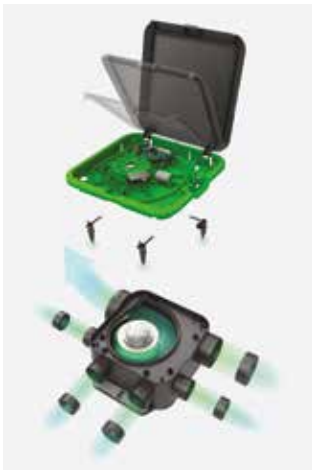

Fonctionnement en vue éclatée

- 4 multi-pollutant sensors:
- > 1 central VCO/H2O sensor fitted on the fan,
 - > 3 remote H2O sensors in the kitchen and bathroom connections.

11033061

EasyHOME PureAIR COMPACT Connect

Curve

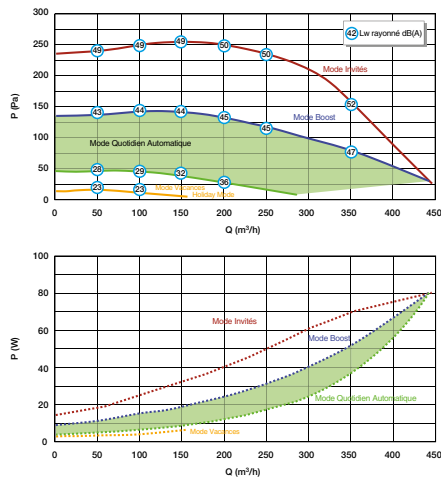

Aerologic and acoustic curve EasyHOME PureAIR COMPACT Connect