

Insulation of ductwork branch

11033059

EasyHOME PureAIR COMPACT Premium unit

EasyHOME PureAIR Premium & Connect renews and purifies the air inside your dwelling using VOC and H2O sensors and its 4 purification modes.



PRODUCT BENEFITS

- 4 multi-pollutant sensors to detect and remove volatile organic compounds (VOCs), CO2 and humidity,
- Connected solution offering 4 remote-controlled ventilation modes along with indoor and outdoor air quality monitoring,
- 77% recycled plastic.

REGULATIONS AND COMPLIANCES

Identification no. QB37 : NA
Technical Opinion no. : NA

Principles of operation

EasyHOME PureAIR Premium and purifies the air inside your dwelling. Using its air quality sensors, it detects VOC, CO2 and humidity. It also automatically and efficiently removes contaminated air from the dwelling using 4 different purification modes.

Product description

EasyHOME PureAIR COMPACT Premium and Connect is a ventilation solution that monitors the quality of the air you breathe 24h/24. It detects volatile organic compounds (VOC), CO2 and humidity, then automatically and efficiently removes contaminated air from the dwelling via one of its 4 ventilation modes.

The PureAIR COMPACT Premium and Connect unit is fitted with a very low consumption motor and 4 electronic multi-pollutant sensors: 1 central VOC / CO2 sensor located on the fan motor and 3 remote H2O sensors in the kitchen and bathroom connections.

When associated with AirFILTER air inlets fitted with a pollen filter, the PureAIR solution filters incoming air for optimal indoor air quality.

EasyHOME PureAIR COMPACT Premium and Connect is compatible with multiple ducting systems and can be installed with Optiflex semi-rigid ducts for an airtight and efficient system.

EasyHOME PureAIR COMPACT is ultra-flat, extra quiet, and suited to installation in the attic or in small spaces, for example in a suspended ceiling or equipment room.

Installation

- multi-position installation: wall, ceiling, floor, sloped surface,
- just 2 attachment screws: centreline 406 mm,
- built-in anti-vibration strips,
- quick-connect electrical terminal block,
- compatible with all types of ducting:
 - Algaine flexible ducts,
 - Optiflex semi-rigid ducts,
 - Minigaine rigid ducts,
 - ducting must be insulated outside of heated spaces.
- Algaine EasyCLIP accessories supplied: quick-fit connectors and collar clamps for simplified connection of flexible ducts on the unit,
- Optiflex EasyCLIP accessories available as optional extras.

Insulation of ductwork branch

11033059

EasyHOME PureAIR COMPACT Premium unit

Reference arguments

- Application:
 - Individual residential or apartment,
 - Unidirectional ventilation systems,
 - Refurbishment,
 - New system or replacement of existing ventilation system,
 - Connects 1 kitchen and up to 4 bathrooms/WC.
- Description:
 - COMPACT unit made of recyclable plastic material: - 1 x Ø125 connection for kitchen, 4 x Ø80 connections for bathrooms/WC, 1 x Ø160,
 - Exhaust airflow rates controlled according to pollutant levels detected by unit: 1 electronic VOC/H₂O sensor on fan and 3 remote H₂O sensors in the kitchen and bathroom connections.
 - Multi-speed, low consumption EC motor. Speed determined by pollutant levels
 - Connectivity: EasyHOME PureAIR Premium can be connected at a later time with the purchase of an Aldes Connect Box modem.

Main characteristics

- COMPACT unit made of recyclable plastic,
- connections on unit for one kitchen and up to 4 Bath/shower rooms:
 - 1 x Ø 125 mm connection for kitchen,
 - 4 x Ø 80 mm connections for bathroom/WC,
 - 1 x Ø 160 mm outlet.
- installation symbols on the unit and accessories,
- exhaust airflows controlled according to pollutant concentration detected by the unit,
- 4 ventilation modes: HOLIDAY, AUTO, BOOST, GUEST,
- multi-speed EC motor,
- connectivity:
 - EasyHOME PureAir Connect supplied with AldesConnect® Box modem for real-time monitoring of indoor and outdoor air quality, remote control via Aldes-Connect® phone app,
 - EasyHOME PureAIR Premium can be connected later with the purchase of an AldesConnect® Box modem,
- kits supplied with 3 ColorLINE® ventilation grilles and 4 AirFILTER air inlets.

Supplementary characteristics

- 4 operating modes that can be controlled and programmed using the AldesConnect® app:
 - HOLIDAY mode*: minimum air renewal for prolonged periods of absence,
 - AUTO mode: day-to-day operating mode, continuously variable with automatic speed control according to the level of VOC and H₂O pollutants detected,
 - BOOST mode for bathrooms and kitchen: automatic high speed when humidity levels rise in bathrooms or the kitchen,
 - GUEST mode*: maximum speed in case of high CO₂ level due to high occupancy of dwelling,
 - *HOLIDAY and GUEST modes accessible as optional extras on EasyHOME PureAIR Premium, by adding an AldesConnect® Box modem.

Contents of kits

- VOC/CO₂ sensor;1
- humidity sensor;3
- calibrated hole for kitchen;1
- calibrated hole for bathroom;2
- calibrated hole for WC;2
- plug Ø 80 mm;2

Accessories

Description	Variants
Outlet adapter EasyHOME Ø160/125 mm	11026025
Collar + connector EasyCLIP Ø125 mm	11033010
Collar + connector EasyCLIP Ø80 mm	11033011
Connector EasyCLIP + collar Ø 160 mm	11033016
CMEV push button for BAHIA CURVE terminal	11026011
OPTIFLEX® EasyClip accessory kit for EasyHOME units	11091994

General data

Variants	Number of connections Ø 125 mm	Number of connections Ø 80 mm	Maximum number of bathrooms/WC	Number of speeds	Motor Type
11033059	1	4	4	multi-speed	EC

Insulation of ductwork branch

11033059

EasyHOME PureAIR COMPACT Premium unit

Dimensional data

Variants	H (mm)	L (mm)	P (mm)	Ø discharge (mm)	Weight (kg)
11033059	187	459	460	160	3,9

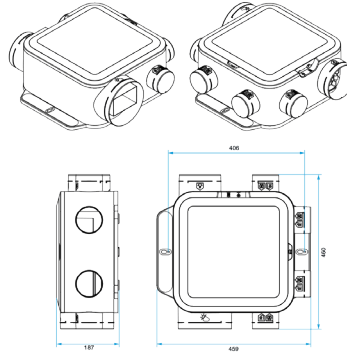

Airflow data

Variants	Max. airflow ErP (m³/h)
11033059	400

Acoustic data

Variants	Sound pressure at 2 m from the kitchen terminal (dB(A))	Sound power at kitchen terminal (dB(A))	Sound power at the unit at 100 m³/h (dB(A))	Sound power ErP (dB(A))
11033059	9	26	30	44

Heat recovery data

Variants	Average daily consumption 2-bed dwelling (1 bathroom + 1 WC) (W)	Max. power in BOOST mode (W)
11033059	7	7

Electrical datas

Variants	Voltage (V)	Frequency (Hz)	Max. power	Max. current (A)	Protection current (A)
11033059	230	50	85	0,8	2

Insulation of ductwork branch

11033059

EasyHOME PureAIR COMPACT Premium unit

Regulatory data

Variants	Energy class – Average climate
11033059	B

Installation



Montage faux-plafond

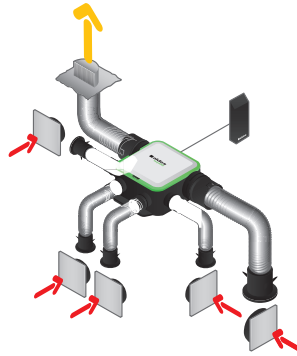

Installation avec conduits souples Algaïne

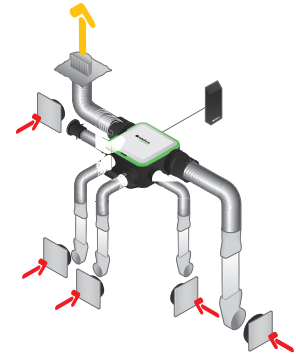

Installation avec conduits rigides Minigaine

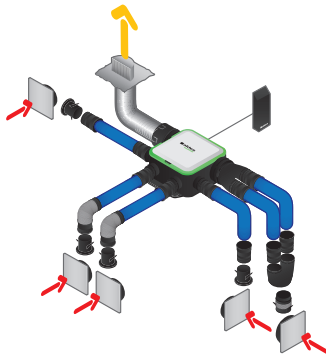

Installation avec conduits semi-rigides Optiflex



EasyCLIP Algaïne

Principles of operation

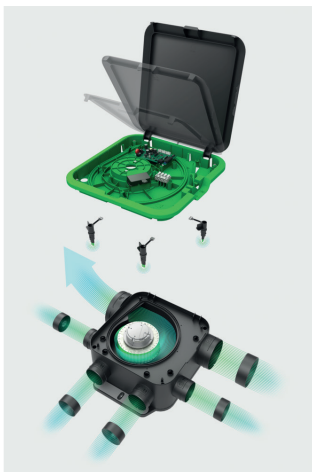

Fonctionnement en vue éclatée

4 multi-pollutant sensors:

- > 1 central VCO/H₂O sensor fitted on the fan,
- > 3 remote H₂O sensors in the kitchen and bathroom connections.

Insulation of ductwork branch

11033059

EasyHOME PureAIR COMPACT Premium unit

Curve

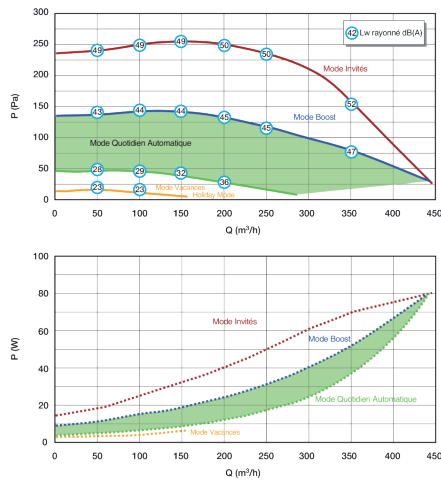

HOLIDAY and GUEST modes are optionally accessible on EasyHOME® PureAIR Premium by adding the AldesConnect Box™ modem.