

Ventilation box fan**11034614****EasyVEC® Compact 1000 MICRO-WATT IP Insulated**

The best-designed range of exhaust box fans on the market, making ventilation efficient, serene, and easy.



EasyVEC-Compact-MWPlus



EasyVEC-Compact-MWPlus

PRODUCT BENEFITS

- wide range from 300 to 3,000 m³/h,
- compact size,
- 100% recyclable.

REGLEMENTATIONS AND COMPLIANCES

Technical Opinion no.: 14.5/16-2185_V2

Principles of operation

EasyVEC® Compact Micro-watt delivers exhaust ventilation in non-residential buildings via air exhaust or supply to ensure sufficient air quality and to preserve the building structure.

Product description

With its compact dimensions and in-line configuration, this unit is ideal for applications in a suspended ceiling.

The Micro-watt constant pressure controller enables significant savings on heating costs compared to a non-regulated (Standard) fan unit.

AldesConnect™ Pro can remotely monitor the fan unit for greater responsiveness in handling breakdowns and malfunctions.

Fields of application

New, Refurbishment, Non-residential buildings

Installation

- installation:
 - indoor or outdoor,
 - installation in suspended ceiling, pack of 4 adjustable straps 100 mm - 400 mm available to attach box to ceiling or to a beam,
 - outdoors: for roof installation, preferably positioned out of the wind to limit pressure losses at the outlet.
- For better acoustic and aerolic performances, we recommend that you:
 - install sound attenuators at the unit connections,
 - use the ALDES VIRTUO-FIX range of sealed accessories,
 - use MS PRO sealed flexible sleeves to muffle ductwork vibrations.

Reference arguments

- Application:
 - centralised, low-consumption unidirectional air supply or exhaust box fan for commercial CMEV system,
 - refurbishment,
 - suspended ceilings / Attic / equipment rooms / flat roofs,
 - air supply /exhaust,
 - indoor / outdoor / horizontal / vertical.
- Description:
 - EasyVEC® Compact Micro-Watt low-consumption exhaust box fan,
 - Micro-watt controller for pressure control,
 - easy to select: Selector poWair® and Conceptor Ventilation design software,
 - easy to configure via intuitive interface,
 - easy to service: link to documentation via QR code, single access panel, compatible with AldesConnect™ Pro supervision service (optional),
 - low power consumption.

Ventilation box fan

11034614

EasyVEC® Compact 1000 MICRO-WATT IP Insulated

Main characteristics

- 2 control modes: constant pressure to minimise consumption or via external 0-10V probe,
- EC low-consumption motor (50/60Hz),
- backward curve impeller,
- unit made of galvanised steel Z275,
- simple and intuitive EasyVEC® remote control,
- proximity switch as standard,
- compatible with all types of ductwork, even with junctions,
- central system: savings on maintenance,
- alarm relay available by wiring to the PCB,
- multiple options and accessories:
 - filter box,
 - ISO filter coarse 60%, ePM10 50%, ePM1 50-75%, ePM1 85%,
 - pressure switch,
 - ducted discharge,
 - 25 mm dual-wall acoustic insulation,
 - compatible with Modbus RS485,
 - AldesConnect® Pro.
- made in France.

Supplementary characteristics

- compatible with Technical Approval for Modulated Ventilation - Presence-Agito-CO2-Hygro no. 14.5/16-2185_V1,
- ErP 2018,
- ECS-eligible: BAT-TH-112, BAT-TH-125, BAT-EQ-123.

Accessories

Désignations	References
Circuit breaker 1.0A to 1.6A	11056184
BCA Mono single phase D250 4.5 kW + relay	11090793
BCA Ø 250 - 2 kW - 1C	11090759
BCA Ø 250 - 1 kW - 1C	11090758
BCA Ø 250 - 3 kW - 1C	11090760
BCA Ø 250 - 4.5 kW - 2C	11090761
BCA R Mono regulated 1-phase coil Ø 250 - 4.5 kW	11090807
BCA R Mono regulated 1-phase coil Ø 250 - 2.5 kW	11090806
BCA R Tri regulated 3-phase coil Ø 250 - 9 kW	11090823
BCA R Tri regulated 3-phase coil Ø 250 - 4.5 kW	11090822
Duct sensor +25/+90°C	11090900
Airflow control kit (20-300 Pa)	11090901
Duct sensor -10/+35°C	11090902
Female rain hood + screen Ø 250 mm	11056373

Consumables

Désignations	References
F7 filter EasyVEC® Compact 1000	11034419
G4 filter EasyVEC® Compact 1000	11034403

Associated services

Commissioning

General data

References	Type of motor
11034614	EC

Ventilation box fan

11034614

EasyVEC® Compact 1000 MICRO-WATT IP Insulated

Dimensional data

References	B (mm)	C (mm)	E (mm)	F (mm)	H (mm)	P (mm)	R (mm)	Ø (mm)	Weight (kg)
11034614	67	532	178	588	354	527	532	250	22

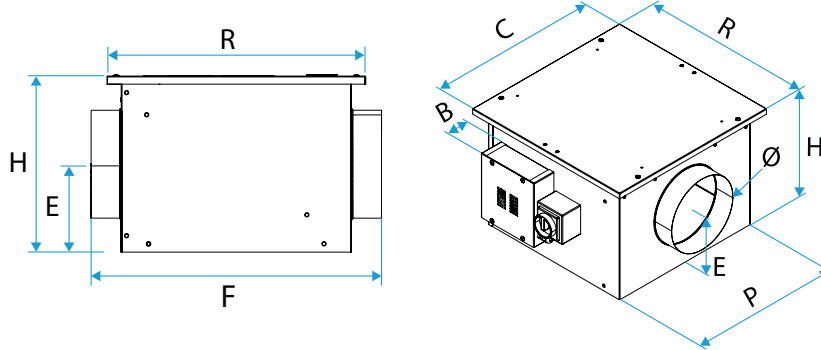

EasyVEC-Compact

Airflow data

References	Airflow (m³/h)
11034614	1000

Electrical datas

References	Protection rating	Maximum current (A)	Maximum power (W)	Power supply	Max. power
11034614	IP24	1,3	164	Single-phase	164

Installation visual 1

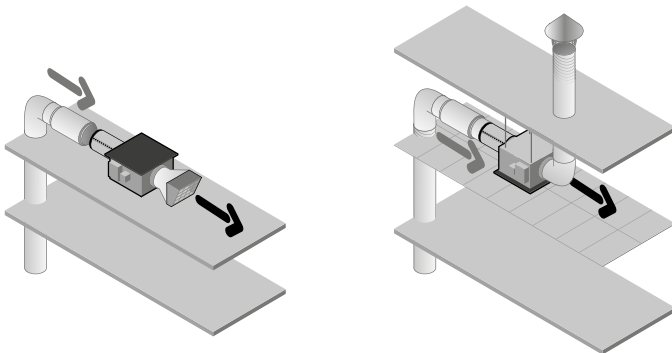

EasyVEC-Compact

Curve

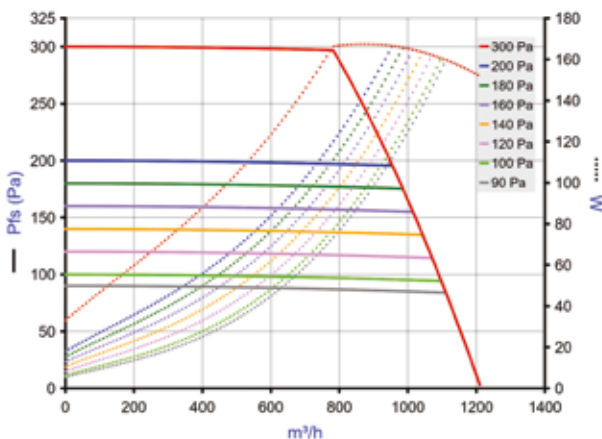

- > Aeraulic curves drawn up as per standard NF EN ISO 5801.
- > P (Pa) = static pressure.
- > P (W) = power consumption.

EasyVEC-Compact-1000