

# 11034541

## EasyVEC® Compact 3000 1SP Insulated

The best-designed range of exhaust box fans on the market, making ventilation efficient, serene, and easy.



### PRODUCT BENEFITS

- wide range from 300 to 3,000 m<sup>3</sup>/h
- compact size,
- 100% recyclable.

### REGULATIONS AND COMPLIANCES

Technical Opinion no.: 14.5/16-2185\_V2

### Principles of operation

EasyVEC® Compact Standard delivers exhaust ventilation in non-residential buildings, via air supply or exhaust.

With its compact dimensions and in-line configuration, this unit is ideal for applications in a suspended ceiling, where it will ensure adequate air quality and preserve the building structure.

### Produktbeskrivelse

With its compact dimensions and in-line configuration, this unit is ideal for applications in a suspended ceiling.

### Fields of application

Multi-occupancy residential housing, New, Refurbishment, Non-residential buildings

### Installation

- installation:
  - indoor or outdoor,
  - installation in suspended ceiling, pack of 4 adjustable straps 100 mm - 400 mm available to attach box to ceiling or to a beam,
  - outdoors: for roof installation, preferably positioned out of the wind to limit pressure losses at the outlet.
- For better acoustic and aeraulic performances, we recommend that you:
  - install sound attenuators at the unit connections,
  - use the ALDES VIRTUO-FIX range of sealed accessories,
  - use MS PRO sealed flexible sleeves to muffle ductwork vibrations.

### Reference arguments

- Application:
  - standard centralised unidirectional air supply or exhaust fan for commercial CMEV system,
  - refurbishment,
  - suspended ceilings / Attic / equipment rooms / flat roofs,
  - air supply /exhaust,
  - indoor / outdoor / horizontal / vertical,
- Description:
  - EasyVEC® Compact Standard exhaust box fan with airflow of 3000 m<sup>3</sup>/h,
  - easy to select: Selector poWair and Conceptor Ventilation design software,
  - easy to service: link to documentation via QR code, single access panel.

## 11034541 EasyVEC® Compact 3000 1SP Insulated

### Main characteristics

- AC motor,
- backward curve impeller,
- galvanised panels Z275.
- multiple options and accessories:
  - filter box,
  - ISO Coarse filter 60%, ePM10 50%, ePM1 50-75%,
  - filter replacement indicator
  - pressure switch,
  - 25 mm double-skin acoustic insulation,
- made in France.

### Supplementary characteristics

- compatible with technical Approval for Modulated Ventilation Presence-Agito-CO2-Humidity-controlled no. 14.5/16-2185\_V1,
- ErP 2018,
- Eligible for ESC: BAT-TH-112, BAT-TH-125, BAT-EQ-123.

### Accessories

Description	Variants
Circuit breaker 4A - 6.3A	11057054
BCA Mono single phase D400 6 kW + relay	11090798
BCA Ø 400 - 6 kW - 2C	11090771
BCA Ø 400 - 3 kW - 1C	11090770
BCA R Mono regulated 1-phase coil Ø 400 - 7.5 kW	11090811
BCA R Tri regulated 3-phase coil Ø 400 - 15 kW	11090829
Duct sensor +25/+90°C	11090900
BCA R Tri regulated 3-phase coil Ø 400 - 7.5 kW	11090828
Airflow control kit (20-300 Pa)	11090901
Duct sensor -10/+35°C	11090902
EC motor 0-10V 20K potentiometer for TAHA-TAVA micro-watt	11024468
Female rain hood + screen Ø 400 mm	11056100
EasyVEC Compact 3000 filter box	11034528
OCTA D400 sealed	11094638
OCTA with baffle D400	11094993
MS PRO V2 D400	11094300

### Dimensional data

Variants	B (mm)	C (°)	C (mm)	E (mm)	F (mm)	H (mm)	P (mm)	R (mm)	Ø (mm)	Weight (kg)
11034541	73	694	694	232	760	465	689	694	400	46

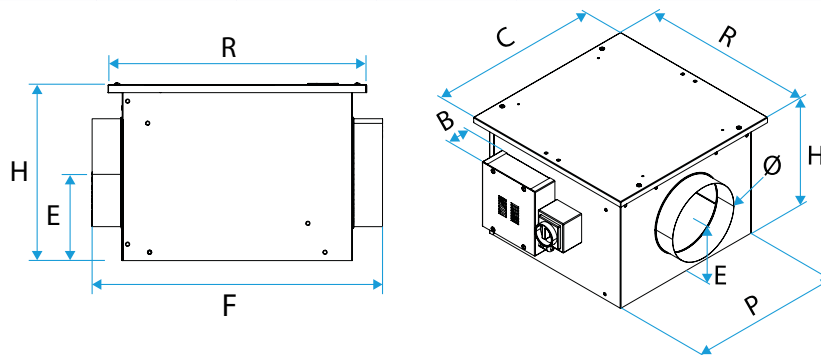

### Airflow data

Variants	Airflow (m³/h)
11034541	3000

# 11034541

## EasyVEC® Compact 3000 1SP Insulated

### Electrical datas

Variants	Protection rating	Maximum current (A)	Maximum power (W)	Power supply	Max. power	Max. power
11034541	IP24	2,94	618	Single-phase	0,618	618

### Installation

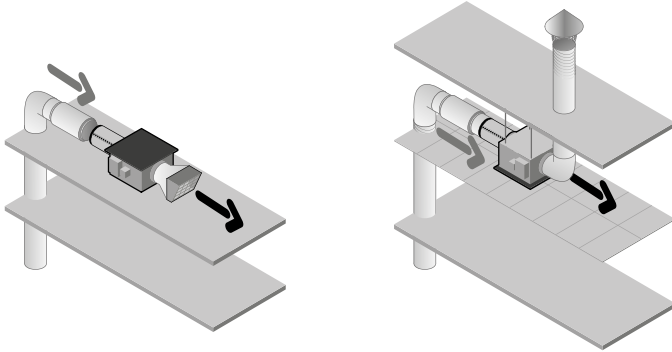

EasyVEC-Compact