

Ventilation box fan

11034549

EasyVEC® Compact Standard 600

The best-designed range of exhaust box fans on the market, making ventilation efficient, serene, and easy.



EasyVEC-Compact



EasyVEC-Compact

PRODUCT BENEFITS

- wide range from 300 to 3,000 m³/h
- compact size,
- 100% recyclable.

REGLEMENTATIONS AND COMPLIANCES

Technical Opinion no.: 14.5/16-2185_V2

Principles of operation

EasyVEC® Compact Standard delivers exhaust ventilation in non-residential buildings, via air supply or exhaust.

With its compact dimensions and in-line configuration, this unit is ideal for applications in a suspended ceiling, where it will ensure adequate air quality and preserve the building structure.

Product description

With its compact dimensions and in-line configuration, this unit is ideal for applications in a suspended ceiling.

Fields of application

New, Refurbishment, Non-residential buildings

Installation

- installation:
 - indoor or outdoor,
 - installation in suspended ceiling, pack of 4 adjustable straps 100 mm - 400 mm available to attach box to ceiling or to a beam,
 - outdoors: for roof installation, preferably positioned out of the wind to limit pressure losses at the outlet.
- For better acoustic and aeraulic performances, we recommend that you:
 - install sound attenuators at the unit connections,
 - use the ALDES VIRTUO-FIX range of sealed accessories,
 - use MS PRO sealed flexible sleeves to muffle ductwork vibrations.

Reference arguments

- Application:
 - standard centralised unidirectional air supply or exhaust fan for commercial CMEV system,
 - refurbishment,
 - suspended ceilings / Attic / equipment rooms / flat roofs,
 - air supply /exhaust,
 - indoor / outdoor / horizontal / vertical,
- Description:
 - EasyVEC® Compact Standard exhaust box fan with airflow of 2,000 m³/h,
 - easy to select: Selector poWair and Conceptor Ventilation design software,
 - easy to service: link to documentation via QR code, single access panel.

Ventilation box fan

11034549

EasyVEC® Compact Standard 600

Main characteristics

- AC motor,
- backward curve impeller,
- galvanised panels Z275.
- multiple options and accessories:
 - filter box,
 - ISO Coarse filter 60%, ePM10 50%, ePM1 50-75%,
 - filter replacement indicator
 - pressure switch,
 - 25 mm double-skin acoustic insulation,
- made in France.

Supplementary characteristics

- compatible with technical Approval for Modulated Ventilation Presence-Agito-CO2-Humidity-controlled no. 14.5/16-2185_V1,
- ErP 2018,
- Eligible for ESC: BAT-TH-112, BAT-TH-125, BAT-EQ-123.

Accessories

Désignations	References
Circuit breaker 1.0A to 1.6A	11056184
BCA Mono single phase D200 2 kW + relay	11090791
BCA Ø 200 - 1 kW - 1C	11090755
BCA Ø 200 - 2 kW - 1C	11090756
BCA Ø 200 - 3 kW - 1C	11090757
BCA R Mono regulated 1-phase coil Ø 200 - 1.5 kW	11090804
BCA R Tri regulated 3-phase coil Ø 200 - 6 kW	11090821
BCA R Mono regulated 1-phase coil Ø 200 - 3 kW	11090805
Duct sensor +25/+90°C	11090900
Airflow control kit (20-300 Pa)	11090901
Duct sensor -10/+35°C	11090902
Female rain hood + screen Ø 200 mm	11056102
	11086572

Associated services

Commissioning

General data

References	Type of motor
11034549	AC

Dimensional data

References	B (mm)	C (mm)	E (mm)	F (mm)	H (mm)	P (mm)	R (mm)	Ø (mm)	Weight (kg)
11034549	93	482	164	538	327	427	482	200	12

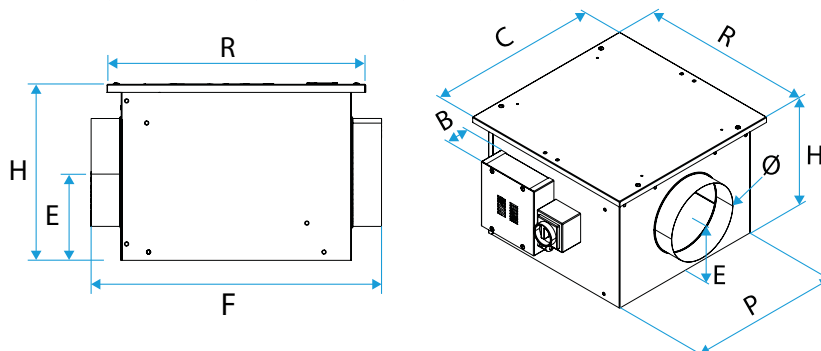

EasyVEC-Compact

Airflow data

References	Airflow (m³/h)
11034549	600

Ventilation box fan

11034549

EasyVEC® Compact Standard 600

Electrical datas

References	Protection rating	Maximum current (A)	Maximum power (W)	Power supply	Max. power
11034549	IP24	0,8	184	Single-phase	184

Installation visual 1

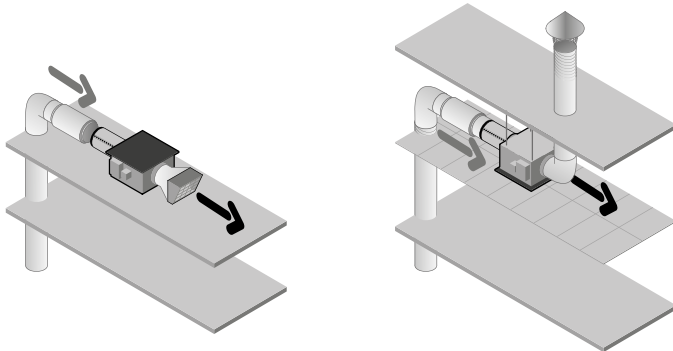

EasyVEC-Compact

Curve

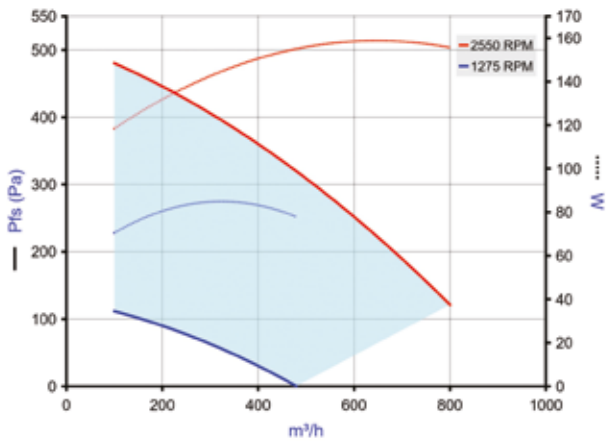

EasyVEC-Compact-600

- > Aerulic curves drawn up as per standard NF EN ISO 5801.
- > P (Pa) = static pressure.
- > P (W) = power consumption.