

Ventilation box fan**11034508****EasyVEC® Standard 4000 IP**

The best-designed range of exhaust box fans on the market, making ventilation efficient, serene, and easy.



EasyVEC-Standard-4000



EasyVEC-Standard-4000

PRODUCT BENEFITS

- wide range from 4000 to 12,000 m³/h,
- 100% recyclable.

REGLEMENTATIONS AND COMPLIANCES

Technical Opinion no.: 14.5/16-2185_V2

Principles of operation

EasyVEC® Standard delivers unidirectional ventilation in commercial buildings, via air supply or exhaust.

Product description

EasyVEC® Standard delivers unidirectional ventilation in commercial buildings by air supply or exhaust, to ensure adequate air quality and preservation of the building structure.

Fields of application

New, Refurbishment, Non-residential buildings

Installation

- installation:
 - on anti-vibration slab as per DTU 68.3 recommendations,,
 - indoor or outdoor location,
 - sufficient space must be left in front of the box fan to avoid obstructing the access panel and allow maintenance of internal components.
 - for roof installation, preferably positioned out of the wind to limit pressure losses at the outlet.
- for better acoustic and aeraulic performance, we recommend that you:
 - install sound attenuators at the unit connections,
 - use the ALDES VIRTUO-FIX range of sealed accessories,
 - use MS PRO sealed flexible sleeves to muffle ductwork vibrations.

Reference arguments

- Application:
 - centralised, low-consumption unidirectional air supply or exhaust box fan for commercial CMEV system,
 - new and refurbishment,
 - air supply /exhaust,
 - attic / equipment rooms / flat roofs,
 - indoor / outdoor.
- Description:
 - EasyVEC® Standard box fan,
 - easy to select: Selector poWair and Conceptor Ventilation design software,
 - easy to service: link to documentation via QR code, single access panel.

Ventilation box fan

11034508

EasyVEC® Standard 4000 IP

Main characteristics

- AC motor,
- backward curve impeller,
- galvanised panels Z275.
- multiple options and accessories:
- filter box,
- ISO coarse filter 60% ePM10 50%, ePM1 50-75%, ePM1 85%,
- filter replacement indicator,
- pressure switch.
- made in France.

Supplementary characteristics

- compatible with technical Approval for Modulated Ventilation Presence-Agito-CO2-Humidity-controlled no. 14.5/16-2185_V1,
- ErP 2018,
- Eligible for ESC: BAT-TH-112, BAT-TH-125, BAT-EQ-123.

Accessories

Désignations	References
Circuit breaker 4A - 6.3A	11057054
BCA Ø 500 - 30 kW - 6C	11090781
BCA Ø 500 - 36 kW - 6C	11090782
BCA Ø 500 - 12 kW - 3C	11090775
BCA Ø 500 - 18 kW - 6C	11090780
BCA R Tri regulated 3-phase coil Ø 500 - 9 kW	11090832
BCA R Tri regulated 3-phase coil Ø 500 - 18 kW	11090833
Duct sensor +25/+90°C	11090900
Airflow control kit (20-300 Pa)	11090901
Duct sensor -10/+35°C	11090902
Female rain hood + screen Ø 500 mm	11056374

Consumables

Désignations	References
M5 filter EasyVEC® 4000	11034412
F7 filter EasyVEC® 4000	11034415
F9 filter EasyVEC® 4000	11034426
G4 filter EasyVEC® 4000	11034409

Options

base
CIRC
DP
EXPORT
INDIC
ISOLA
RAILS
REGLABLE
TT_EN_UN
VARI5

Associated services

Commissioning

General data

References	Type of motor
11034508	AC

Ventilation box fan

11034508

EasyVEC® Standard 4000 IP

Dimensional data

References	E (mm)	F (mm)	H (mm)	L (mm)	M (mm)	P (mm)	T (mm)	Y (mm)	Z (mm)	Ø (mm)
11034508	450	910	665	690	60	700	740	720	115	500

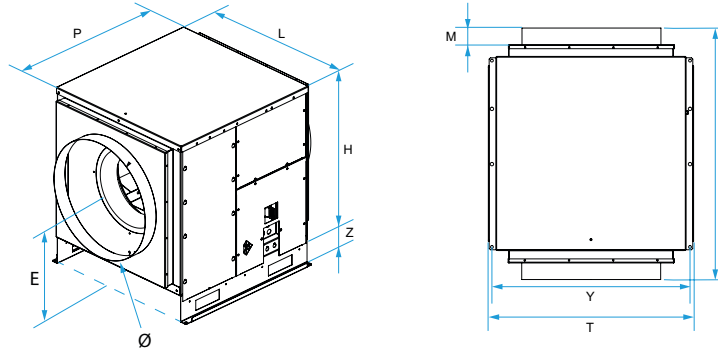

EasyVEC® Standard

Airflow data

References	Airflow (m³/h)
11034508	4000

Electrical datas

References	Protection rating	Maximum current (A)	Maximum power (W)	Power supply	Max. power
11034508	IP24	5.2	720	Single-phase	720

Installation visual 1

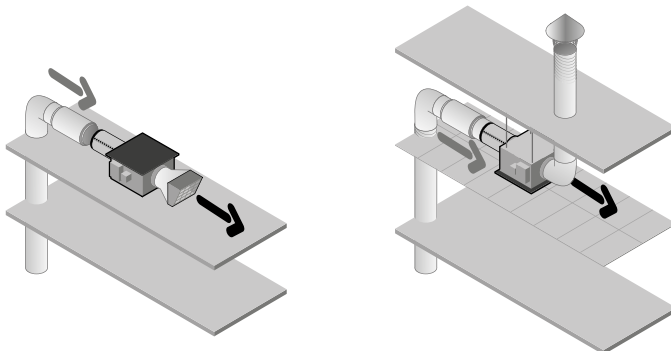

EasyVEC-Compact

Curve

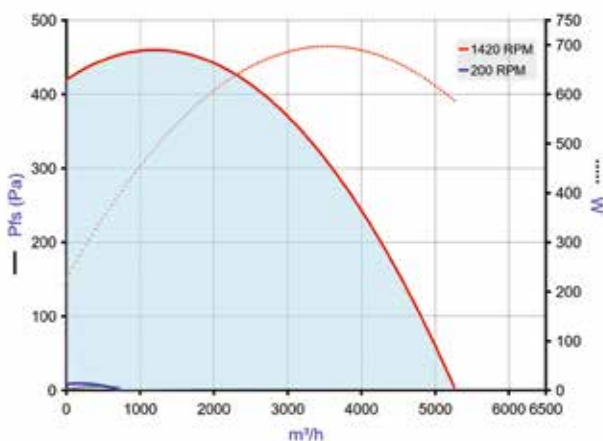

EasyVEC-Standard-4000

- > Aeraulic curves drawn up as per standard NF EN ISO 5801.
- > P (Pa) = static pressure.
- > P (W) = power consumption.