

**Ventilation box fan****11034511****EasyVEC® Standard 8000 IP**

The best-designed range of exhaust box fans on the market, making ventilation efficient, serene, and easy.



EasyVEC-Standard-4000



EasyVEC-Standard-4000

**PRODUCT BENEFITS**

- wide range from 4000 to 12,000 m<sup>3</sup>/h,
- 100% recyclable.

**REGLEMENTATIONS AND COMPLIANCES**

Technical Opinion no.: 14.5/16-2185\_V2

**Principles of operation**

EasyVEC® Standard delivers unidirectional ventilation in commercial buildings, via air supply or exhaust.

**Product description**

EasyVEC® Standard delivers unidirectional ventilation in commercial buildings by air supply or exhaust, to ensure adequate air quality and preservation of the building structure.

**Fields of application**

New, Refurbishment, Non-residential buildings

**Installation**

- installation:
  - on anti-vibration slab as per DTU 68.3 recommendations,,
  - indoor or outdoor location,
  - sufficient space must be left in front of the box fan to avoid obstructing the access panel and allow maintenance of internal components.
  - for roof installation, preferably positioned out of the wind to limit pressure losses at the outlet.
- for better acoustic and aeraulic performance, we recommend that you:
  - install sound attenuators at the unit connections,
  - use the ALDES VIRTUO-FIX range of sealed accessories,
  - use MS PRO sealed flexible sleeves to muffle ductwork vibrations.

**Reference arguments**

- Application:
  - centralised, low-consumption unidirectional air supply or exhaust box fan for commercial CMEV system,
  - new and refurbishment,
  - air supply /exhaust,
  - attic / equipment rooms / flat roofs,
  - indoor / outdoor.
- Description:
  - EasyVEC® Standard box fan,
  - easy to select: Selector poWair and Conceptor Ventilation design software,
  - easy to service: link to documentation via QR code, single access panel.

## Ventilation box fan

11034511

EasyVEC® Standard 8000 IP

## Main characteristics

- AC motor,
- backward curve impeller,
- galvanised panels Z275.
- multiple options and accessories:
- filter box,
- ISO coarse filter 60% ePM10 50%, ePM1 50-75%, ePM1 85%,
- filter replacement indicator,
- pressure switch.
- made in France.

## Supplementary characteristics

- compatible with technical Approval for Modulated Ventilation Presence-Agito-CO2-Humidity-controlled no. 14.5/16-2185\_V1,
- ErP 2018,
- Eligible for ESC: BAT-TH-112, BAT-TH-125, BAT-EQ-123.

## Accessories

Désignations	References
BCA R Tri regulated 3-phase coil Ø 630 - 24 kW	11090837
BCA R Tri regulated 3-phase coil Ø 630 - 12 kW	11090836
Duct sensor +25/+90°C	11090900
BCA R Tri regulated 3-phase coil Ø 630 - 36 kW	11090838
Airflow control kit (20-300 Pa)	11090901
Duct sensor -10/+35°C	11090902
Female rain hood + screen Ø 630 mm	11056375

## Consumables

Désignations	References
G4 filter EasyVEC® 5000/6500/8000	11034410
M5 filter EasyVEC® 5000/6500/8000	11034413
F7 filter EasyVEC® 5000/6500/8000	11034416
F9 filter EasyVEC® 5000/6500/8000	11034427

## Options

base
CIRC
DP
EXPORT
INDIC
ISOLA
RAILS
REGLABLE
TT_EN_UN
VARI5

## Associated services

Commissioning

## General data

References	Type of motor
11034511	AC

Ventilation box fan

11034511

EasyVEC® Standard 8000 IP

Dimensional data

References	E (mm)	F (mm)	H (mm)	L (mm)	M (mm)	P (mm)	T (mm)	Y (mm)	Z (mm)	Ø (mm)
11034511	500	975	760	790	60	765	835	815	115	630

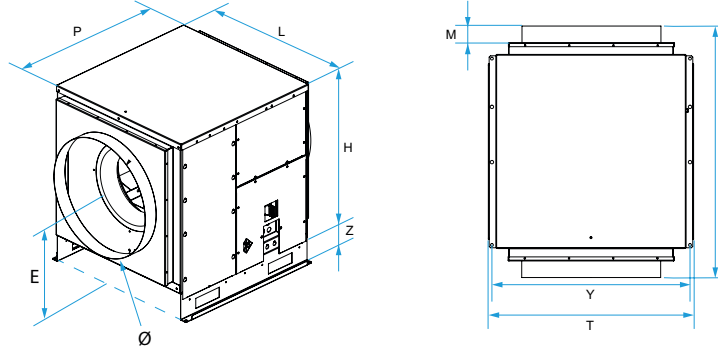

EasyVEC® Standard

Airflow data

References	Airflow (m³/h)
11034511	8000

Electrical datas

References	Protection rating	Maximum current (A)	Maximum power (W)	Power supply	Max. power
11034511	IP24	11	1750	Single-phase	1750

Installation visual 1

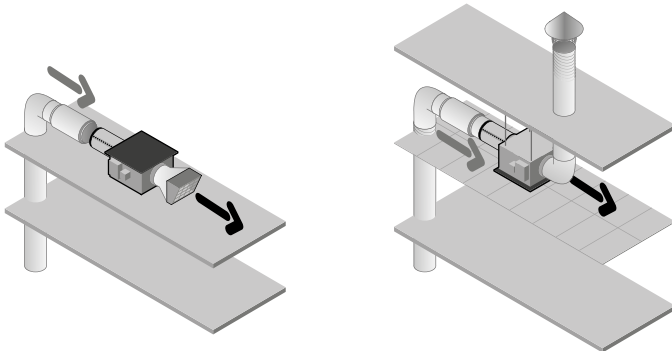

EasyVEC-Compact

Curve

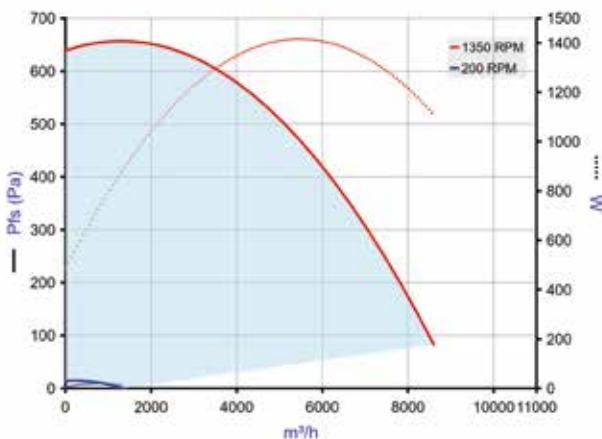

- > Aeraulic curves drawn up as per standard NF EN ISO 5801.
- > P (Pa) = static pressure.
- > P (W) = power consumption.

EasyVEC-Standard-8000