

11045351

GFA 007 OPTONE.H 400X650 CFG

The OPTONE-H «+ Grille» damper is used for smoke and heat exhaust on ducting in residential buildings in categories 3B or 4.



GFA 007 grille for Optone H «Classic

PRODUCT BENEFITS

- metal trim, aesthetic and vandal-proof,
- shallow articulation range,
- simplified cable inputs and outputs.

Principles of operation

The damper is closed in standby position. It opens when instructed by the ORDONE control panel, then moves into safety position.

Product description

The OPTONE-H «+ Grille» damper is used for smoke and heat exhaust on ducting in residential buildings in categories 3B or 4. It is ideal for installation in a standard 400x500 mm duct (20 dm²). The OPTONE-H «+ Grille» damper features a 24V current-make trigger mechanism. However it is not fitted with signal contacts and is unable to receive them.

Fields of application

Multi-occupancy residential housing, New, Refurbishment

Installation

- installation direction: “fire in the duct”,
- surface-mounted on a smoke and heat exhaust duct CF 1h fire rating
- attachment of OPTONE-H «+ Grille» on mounting frame recommended,
- install the OPTONE-H «+ Grille» with the clips at the top to installed the fin core:
 - at the bottom for a VB damper,
 - at the top for a VH damper.
- for installation with mortar-sealed mounting frame on concrete duct, add at least 100 mm for mortar,
- for other dimensions use the OPTONE range.

Main characteristics

- CE marking compliant as per EN 12101-8.
- free air passage of 20.3 dm²,
- first smoke control damper certified EI 60 S compliant with European standard NF EN 1366-10,
- identical damper for smoke and heat exhaust (VH) and air inlet (VB),
- 1-hour fire resistant in accordance with decision of 31 January 1986. Ideal for installation on standard duct 400 x 500 mm,
- electromagnetic trip device VDS 24 V DC auto-reset,
- mounting frame can be installed in factory,
- cable through holes included,
- grille with removable core,
- connection terminal block: protected by a plastic cover,
- individually packed,
- for a damper fitted with signalling contacts, use the OPTONE T damper range.

11045351 GFA 007 OPTONE.H 400X650 CFG

Supplementary characteristics

- mounting frame:
 - galvanised steel 20/10 mm,
 - suited for installation on concrete and on lightweight materials such as Promatect, Supalux or Tecriver,
 - drilled to enable passage of electric cables,
 - fitted with sealing lugs and holes to receive damper screws.
 - top/down reversible,
 - 70 mm depth for good mechanical strength.

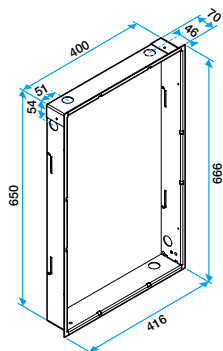

Dimensions of mounting frame (mm)

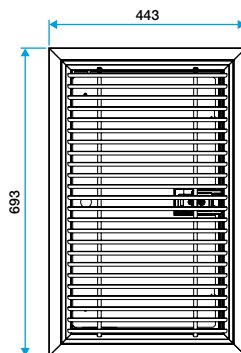

Dimensions front view (mm)

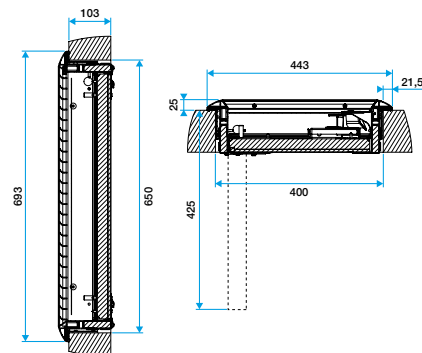

Dimensions top view and profile (mm)