

Axial fan**11090501
HELIONE NC-F200-F400 Ø 350**

HELIONE is a range of axial smoke and heat exhaust fans rated F200-120, F400-120 or unclassified.



HELIONE short ring



HELIONE long ring

PRODUCT BENEFITS

- range up to 128,000 m³/h,
- wide range for car parks, commercial and industrial premises,
- multiple accessories to facilitate operation.

REGLEMENTATIONS AND COMPLIANCES

PV CE number : 1812-CPR-1623

Principles of operation

HELIONE fan units require connection to the ventilation / smoke exhaust circuit to remove stale air and smoke to the outside. They can be controlled by an AXONE safety box or a car park box.

Product description

The standard HELIONE range varies from Ø 355 to Ø 1 250 mm and can reach airflows from 1,500 to 200,000 m³/h. HELIONE is used for ventilation and/or smoke and heat exhaust in residential areas (car parks, stairwells), non-residential premises (car parks, shops), and industrial buildings. It enables fresh air supply and exhaust as well as intermittent smoke and heat exhaust functions or in locations where acoustic limitations are not predominant. HELIONE combines with multiple accessories to assist its operation.

Fields of application

Multi-occupancy residential housing, New, Refurbishment, Non-residential buildings

Installation

- horizontal on floor and against a wall, essential extras:
 - square plate, anti-vibration mountings and feet, flanges and flexible sleeves or grille if not ducted.
- horizontal on floor between two ducts, essential extras:
 - anti-vibration mountings and feet, flanges and flexible sleeves for both sides, long ring for access to motor through access hatch.
- horizontal against a wall, essential extras:
 - reinforced square plate for attachment to wall, flange and flexible sleeve or grille if not ducted.
- vertical suspended under slab or to duct, essential extras:
 - protective screen if access possible or if risk of waste intake,
 - long ring for access to motor if ducted on both sides,
 - gusset bracket option.

Axial fan

11090501

HELIONE NC-F200-F400 Ø 350

Main characteristics

- compliance:
 - certified F400-120 and F200-120,
 - CE compliance: 1812-CPR-1623.
- Ø 355 to Ø 1250 mm, contact us for larger Ø.
- airflow from 1,500 to 120,000 m³/h with pressure values from 100 to 600 Pa,
- impellers:
 - comprise several aluminium blades,
 - fitted on aluminium core,
 - jet angle determined according to operating point.
 - blades: individually X-rayed before assembly to ensure material quality,
- shells:
 - formed from metal sheet,
 - includes drilled rebate flanges for connections,
 - standard = short ring, long ring optional.
- motor attachment arm: hot-dip galvanised for good corrosion resistance,
- motors:
 - bossed,
 - 4 poles or 4/8 poles (2 poles on request),
 - IP55, class F insulation as standard,
 - operating temperature -20/50°C,
 - 60 Hz motor: contact us.

Supplementary characteristics

- installation accessories:
 - flexible sleeve,
 - galvanised steel counter flange to attach Helione to a circular duct,
 - galvanised steel square plate to attach Helione to a wall,
 - galvanised steel support feet (x2) to fasten Helione,
 - anti-vibration mountings (x4) to install under the support feet,
 - non return damper: circular, two galvanised steel flaps,
 - intake nozzle: improved air handling and acoustic performance.
- electrical accessories:
 - proximity switch,
 - pressure switch,
 - safety box see "AXONE micro II".
 - residential car park box
- available options:
 - long shell,
 - gusset brackets for vertical installation,
 - external pre-wired terminal block,
 - protective finish for saline / aggressive environment: hot-dip galvanisation, epoxy powder paint, stainless steel.

Accessories

Désignations	References
Backdraft damper HELIONE Ø 350	11090568
Adapter HELIONE Ø 350	11090529
Fan grille	11090581
Motor grille for short ring fan	11090594
Set of 2 stands HELIONE Ø 350	11090516
Set of 4 pads HELIONE Ø 315 - Ø 800	11090619
Flexible sleeve HELIONE Ø 350	11090542
3-phase 2A autotransformer	11086096
3-phase 4A autotransformer	11086097
Vacuum inlet nozzle HELIONE Ø 350	11090555
Square plate HELIONE Ø 350	11090607

Axial fan

11090501

HELIONE NC-F200-F400 Ø 350

Options

base
3HL/10-10
3HL/12-12
3HL/14-14
3HL/3-6
3HL/4-8
3HL/5-10
3HL/6-12
3HL/6-6
3HL/7-14
3HL/8-8
4Z/12-12
4Z/16-16
4Z/3-9
4Z/5-5
4Z/6-12
4Z/6-9
4Z/7-7
4Z/7-7R
4Z/8-16
4Z/9-9
4ZNAL/3-9
4ZNAL/6-9
4ZNAL/9-9
5Z/12-12
5Z/16-16
5Z/3-9
5Z/5-5
5Z/6-12
5Z/6-9
5Z/8-16
5Z/9-9
6W/10-10
6W/3-6
6W/4-8
6W/5-10
6W/6-6
6W/8-8
9W/10-10
9W/3-6
9W/4-8
9W/5-10
9W/6-6
9W/8-8
GOUSSET
KW0.12
KW0.18
KW0.25
KW0.37
KW0.55
KW0.6
KW0.75+F4001V
KW0.75+ND1V
KW0.8+F4002V
KW0.8+ND2V
KW1.2+F2002V

Axial fan

11090501

HELIONE NC-F200-F400 Ø 350

Options

KW1.2+ND2V
KW1.5+F4002V
KW1.6+F2002V
KW1.6+ND2V
KW11+F2002V
KW11+ND2V
KW14+F2002V
KW14+F4002V
KW14+ND2V
KW17+F2002V
KW17+F4002V
KW17+ND2V
KW18.5+F2001V
KW18.5+F4001V
KW18.5+ND1V
KW2.2+F2002V
KW2.2+F4002V
KW2.2+ND2V
KW20+F2002V
KW20+F4002V
KW20+ND2V
KW3+F2001V
KW3+F4001V
KW3+ND1V
KW3.8+F2002V
KW3.8+F4002V
KW3.8+ND2V
KW30+F2001V
KW30+F2002V
KW30+F4001V
KW30+ND1V
KW35+ND2V
KW37+F2001V
KW37+F2002V
KW37+F4001V
KW37+F4002V
KW37+ND1V
KW37+ND2V
KW4+F2001V
KW4+F4001V
KW4+ND1V
KW44+F2002V
KW44+F4002V
KW44+ND2V
KW45+F2001V
KW45+F4001V
KW45+ND1V
KW5+F2002V
KW5+F4002V
KW5+ND2V
KW5.5+F2001V
KW55+ND2V
KW7.2+F2002V
KW7.2+F4002V
KW7.2+ND2V
KW7.5+F2001V

Axial fan

11090501

HELIONE NC-F200-F400 Ø 350

Options

KW7.5+F4001V
KW7.5+ND1V
KW9.2+ND1V
VIROL2

Dimensional data

References	A (mm)	B (mm)	C (mm)	D (mm)	F (mm)	C long shell (mm)	C short shell (mm)	D short shell (mm)
11090501	350	425	254	540	8	350	460	254

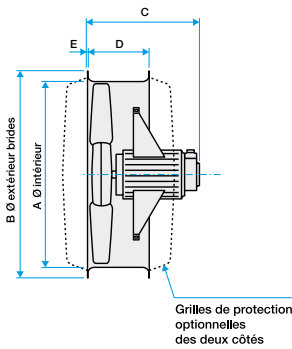

Encombrement virole courte(mm)

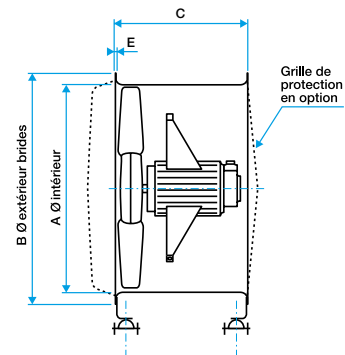

Encombrement virole longue (mm)

Electrical datas

References	Max. current (A)	Max. power	Puissance min (KW)
11090501	3,17	1.5	0,12

Installation visual 1

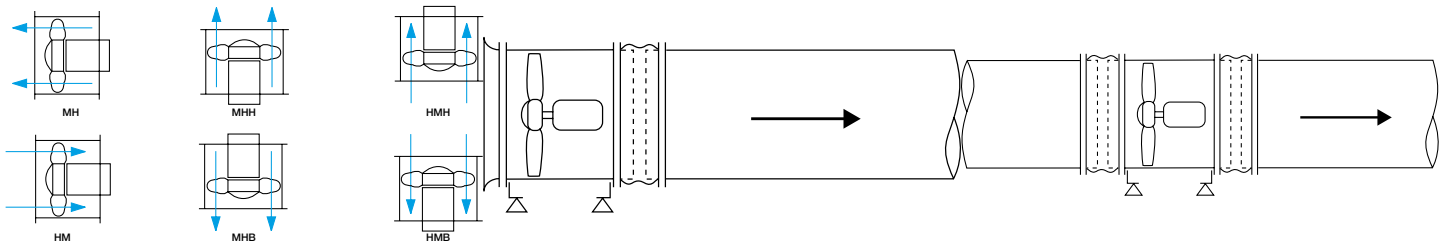

Mise en oeuvre

gainé que d'un coté, horizontal

gainé de chaque coté, (virole longue)

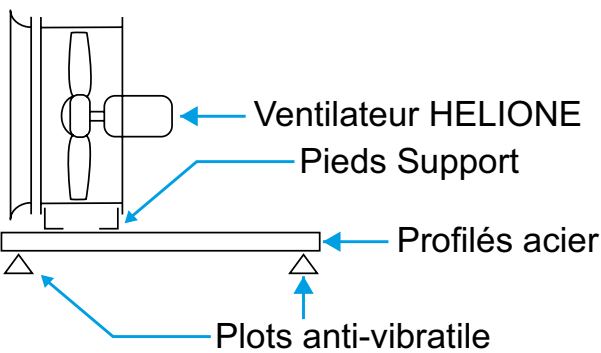

Montage sur structure avec HELIONE virole courte

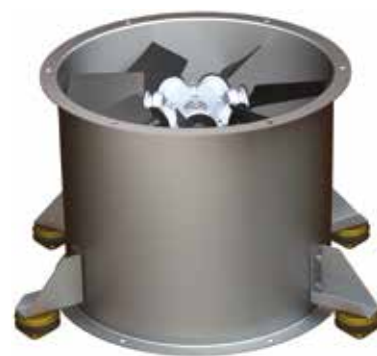

Montage axe vertical sur structure