

**Smoke extraction fan****11022351  
IN LINE XSilent 125**

IN LINE XSilent is a very quiet, high-performance duct fan with a steel casing and 50 mm internal acoustic insulation.

**PRODUCT BENEFITS**

- very quiet due to 50 mm internal insulation: as low as 23 dB(A),
- optimised aeraulic performance,
- steel casing.

**Principles of operation**

The IN LINE XSilent duct fan can ventilate spacious rooms in residential or commercial settings. It can supply or extract air with 1 or 2 ventilation speeds controlled by an inverter or voltage controller.

**Product description**

The IN LINE XSilent duct fan ventilates spacious rooms or environments, while operating at a low noise level: villa, hotel, library, meeting room, cinema, lecture hall, etc.

XSilent can operate in either supply or exhaust directions on circular ducting and can be installed at any point in the system. It offers up to 2 ventilation speeds if connected to an inverter and can operate with a voltage controller.

**Fields of application**

Multi-occupancy residential housing, Individual residential housing, New, Refurbishment

**Installation**

- connected to upstream and downstream ducts,
- can be installed in any position,
- attachment plate for installation on wall,
- can be mounted in series for higher pressure or in parallel for higher airflow,
- fresh air brought into room via air inlet grille or door undercut.
- supports ambient temperature between 1°C and 45°C,
- maximum exhaust air temperature: 60°C.

**Reference arguments**

- Application:
  - Ventilation of one or more rooms,
  - Air supply or exhaust,
  - Installation at any point of the network,
  - Residential (apartment, villa, etc.) and commercial (hotel, library, etc.).
- Description:
  - Duct fan,
  - Painted steel outer casing, ABS inner casing and impeller,
  - Thermal and acoustic insulation featuring 50 mm of rock wool,
  - Single-phase 2-speed high-performance motor.

## Smoke extraction fan

# 11022351

## IN LINE XSilent 125

### Main characteristics

- material:
  - painted steel outer casing,
  - ABS inner casing and impeller.
- thermal and acoustic insulation featuring 50 mm of rock wool,
- 7 models: from Ø 100 mm to Ø 315 mm for maximum airflow from 240 to 1950 m<sup>3</sup>/h,
- single-phase high-performance 2-speed motor mounted on ball bearings,
- built-in thermal protection.

### Contents of kits

- screw and plug;4

### Accessories

Description	Variants
CMEV inverter	11022030
Speed controller 1.5A	11022358

### General data

Variants	Service life (h)	Number of speeds	Motor Type
11022351	40000	2	AC

### Dimensional data

Variants	A (mm)	B (mm)	C (mm)	D (mm)	H (mm)	L (mm)	Ø (mm)	Weight (kg)
11022351	215	474	237	125	237	474	125	4,6

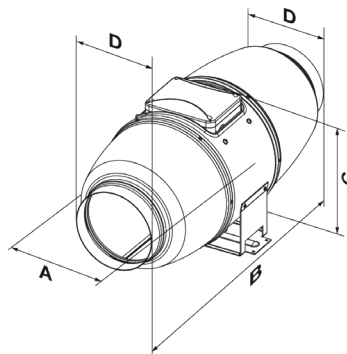

### Airflow data

Variants	Airflow at max. speed (m <sup>3</sup> /h)	Airflow at min. speed (m <sup>3</sup> /h)
11022351	340	155

### Acoustic data

Variants	Sound pressure at 3 m at max. speed (dB(A))	Sound pressure at 3 m at min. speed (dB(A))
11022351	25	16

### Electrical datas

Variants	Voltage (V)	Frequency (Hz)	Max. power	Protection rating	Max. current (A)	Protection current (A)	Min. power
11022351	220/240	50/60	23	IPX4	0,2	2	9

### Regulatory data

Variants	Electrical insulation class
11022351	Class 2

Smoke extraction fan

## 11022351 IN LINE XSilent 125

### Curve

