

Duct fan**11022352
IN LINE XSilent 150**

IN LINE XSilent is a very quiet, high-performance duct fan with a steel casing and 50 mm internal acoustic insulation.



IN LINE XSilent

PRODUCT BENEFITS

- very quiet due to 50 mm internal insulation: as low as 23 dB(A),
- optimised aeraulic performance,
- steel casing.

Principles of operation

The IN LINE XSilent duct fan can ventilate spacious rooms in residential or commercial settings. It can supply or extract air with 1 or 2 ventilation speeds controlled by an inverter or voltage controller.

Product description

The IN LINE XSilent duct fan ventilates spacious rooms or environments, while operating at a low noise level: villa, hotel, library, meeting room, cinema, lecture hall, etc.

XSilent can operate in either supply or exhaust directions on circular ducting and can be installed at any point in the system. It offers up to 2 ventilation speeds if connected to an inverter and can operate with a voltage controller.

Fields of application

Multi-occupancy residential housing, Individual residential housing, New, Refurbishment, Non-residential buildings

Installation

- connected to upstream and downstream ducts,
- can be installed in any position,
- attachment plate for installation on wall,
- can be mounted in series for higher pressure or in parallel for higher airflow,
- fresh air brought into room via air inlet grille or door undercut.
- supports ambient temperature between 1°C and 45°C,
- maximum exhaust air temperature: 60°C.

Reference arguments

- Application:
 - Ventilation of one or more rooms,
 - Air supply or exhaust,
 - Installation at any point of the network,
 - Residential (apartment, villa, etc.) and commercial (hotel, library, etc.).
- Description:
 - Duct fan,
 - Painted steel outer casing, ABS inner casing and impeller,
 - Thermal and acoustic insulation featuring 50 mm of rock wool,
 - Single-phase 2-speed high-performance motor.

Duct fan

11022352
IN LINE XSilent 150

Main characteristics

- material:
 - painted steel outer casing,
 - ABS inner casing and impeller.
- thermal and acoustic insulation featuring 50 mm of rock wool,
- 7 models: from Ø 100 mm to Ø 315 mm for maximum airflow from 240 to 1950 m³/h,
- single-phase high-performance 2-speed motor mounted on ball bearings,
- built-in thermal protection.

Contents of kits

- screw and plug;4

Accessories

Désignations	References
CMEV inverter	11022030
Speed controller 1.5A	11022358

General data

References	Service life (h)	Number of speeds	Type of motor
11022352	40000	2	AC

Dimensional data

References	A (mm)	B (mm)	C (mm)	D (mm)	H (mm)	L (mm)	Ø (mm)	Weight (kg)
11022352	247	580	260	150	260	580	150	6,1

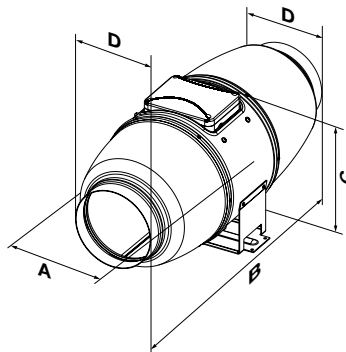

Encombrement en mm

Airflow data

References	Airflow at max. speed (m ³ /h)	Airflow at min. speed (m ³ /h)
11022352	555	405

Acoustic data

References	Sound pressure at 3 m at max. speed (dB(A))	Sound pressure at 3 m at min. speed (dB(A))
11022352	33	26

Electrical datas

References	Frequency (Hz)	Protection current (A)	Max. current (A)	Voltage (V)	Max. power	Min. power
11022352	50/60	2	0,3	220/240	52	45

Regulatory data

References	Electrical insulation class
11022352	Class 2

Duct fan

11022352

IN LINE XSilent 150

Curve

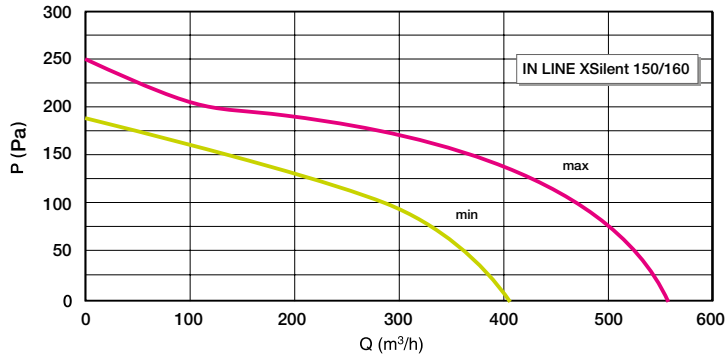

Aeraulic curve XSilent 150