

Fire damper

11043147

ISONE® 2.1 GM FTE70 RECT

ISONE® 2.1 dampers are simple to select: a single model for all partitions and all fire resistance levels.



ISONE2.1 Rectangular PM

PRODUCT BENEFITS

- Single damper model for all partitions: easy to select
- Ergonomic quick reset handle: 2 seconds suffice.
- Optional stainless steel pin for harsh environments
- Optional remote control box, 0.7 m or 3 m cord
- ALDES SecurONE application for damper data collection and sharing
- Single mechanism, from the simplest to the highest-spec damper: easy to choose, install and maintain
- Easy to fit for damper installation in lightweight partition

- The damper is open in standby position.
- It opens when instructed by the FACP or thermal rod and moves into safety position (closed).
- Being motorised, it can be reset remotely.

Product description

Fire dampers for non-residential buildings (public access building, high-rise)

They restore the fire resistance of partition walls crossed by a ventilation duct.

Equipped with 70°C fusible link trip device by default

Controllable by electromagnetic coil trip device: 24/48 V DC current emission; 24 V DC or 48 V DC current break

Reset motor 24/48 V AC/DC

Fire resistance up to 120 minutes on all common partition walls

ISONE® 2.1 Rectangular PM:

- (LxH): from 200x100 to 800x600 mm,

- ISONE® 2.1 control mechanism.

• ISONE® 2.1 GM Rectangular:

- (LxH): L•800, H•600, up to 1500x500 / 1000x1000.

Fields of application

New, Refurbishment, Non-residential buildings

Installation

- Mounted on lightweight partition with no seal, even with post-fitted frame,
- Embedded installation on:
 - Concrete and aerated concrete wall/slab
 - Plaster block wall
 - Type A plasterboards (1h) and type F (2h)
- Remote mounting on PROMAT / GEOSTAF using the EASYNSTALL kits,
- Easy to mount on lightweight partitions thanks to the installation brackets,
- Easynstall kit for simple mounting of rectangular dampers in type A lightweight partition (60 minutes),
- Adapter part for connection to oblong ducting,
- EXAP EN 15882-2:2015, rules X.45 and X.46: extended opening dimensions,
- Comply with fire resistance classification reports during installation.

Main characteristics

- Certified and compliant with NF S 61937-5 and NF 537
- CE marked as per EN 15650: 1812-CPR-1837
- Class C airtight properties as per EN 1751 as standard
- EI 120 S - 500 Pa on concrete / aerated concrete walls and slabs, type F plasterboard, remote installation on PROMAT / Geostaf
- EXAP EN 15882-2:2015, rules X.45 and X.46.
- Range from 200x100 mm to 1500x500 mm / 1000x1000 mm

REGLEMENTATIONS AND COMPLIANCES

PV CE number : 1812-CPR-1837

Fire damper

11043147

ISONE® 2.1 GM FTE70 RECT

Supplementary characteristics

- Fully upgradable mechanism
- Single damper adaptable to all walls
- Lightweight wall installation with post-fitted frame
- Reset handle indicating damper position
- Wide electrical connection box
- Optional stainless steel pin for harsh environments
- Easynstall kit for simple installation in lightweight partition
- Optional remote control unit
- Low pressure loss

Accessories

Désignations	References
OBLONG RING ISONE®2.1 880x215/950x350	11043258
OBLONG RING ISONE®2.1 950x320/1000x350	11043264

General data

References	Free air passage section (dm ²)
11043147	10,3 (Min) - 90,8 (Max)

Dimensional data

References	E (mm)	F (mm)	G (mm)	ZA (mm)	ZB (mm)	Lmax x Hmax (mm)
11043147	50	242	99	Y/2 -122	Y/2 -292	1500 x 500 / 1000 x 1000

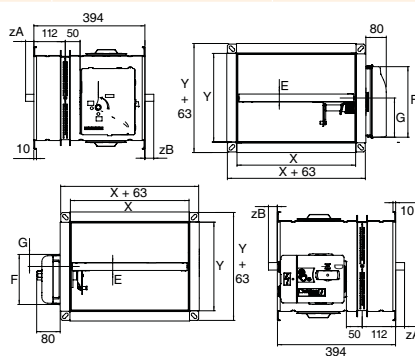

Encombrement ISONE®2.1 Rectangulaire

- ISONE® 2.1 GM: • 800x600 to 1500x500 / 1000²
- ISONE 2.1 PM: 200x100 to 800x600

Fire damper

11043147
ISONE® 2.1 GM FTE70 RECT

Airflow data

References	Pressure loss at 2 m/s (Pa)	Pressure loss at 4 m/s (Pa)	Pressure loss at 6 m/s (Pa)	Pressure loss at 8 m/s (Pa)	Pressure loss at 10 m/s (Pa)	Pressure loss at 12 m/s (Pa)
11043147	0	0	0	0	0	0

Installation visual 1

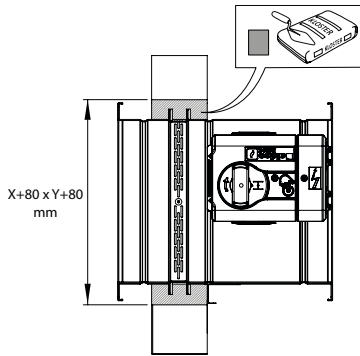

ISONE@2.1 rectangulaire sur mur béton

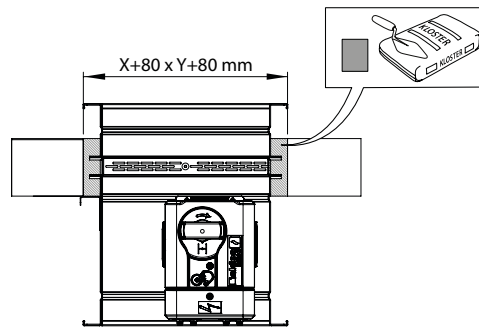

ISONE@2.1 rectangulaire sur dalle béton

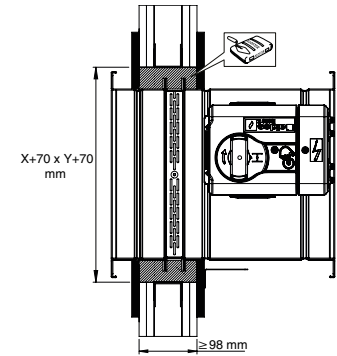

ISONE@2.1 rectangulaire sur cloison légère 120 minutes

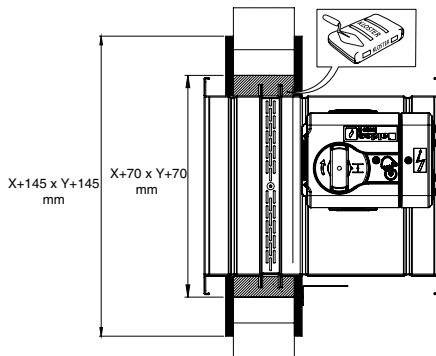

ISONE@2.1 rectangulaire sur cloison carreaux de plâtre 120 minutes

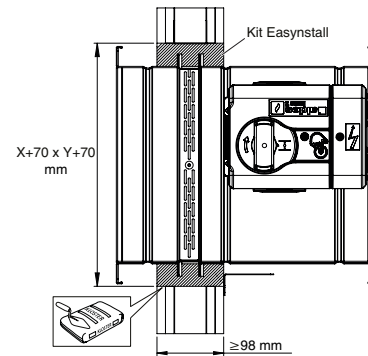

ISONE@2.1 rectangulaire sur cloison légère 60 minutes avec kit Easyinstall

Principe de fonctionnement



- > 1: installation bracket
- > 2: manufacturer's plate
- > 3: ISONE@2.1 PM mechanism
- > 4: blade thickness 25 mm (PM model) or 50 mm (GM model)
- > 5: 30 mm connection flange