

11023290

Nano Air® 50 heat recovery CMEV for individual rooms

The heat recovery ventilation solution for individual rooms, which combine healthier air, preservation of the building and savings on heating costs.



Nano Air 50

PRODUCT BENEFITS

- more ease of installation: no ducts installed in the house.
- more silence: exceptionally low noise level.
- more purified air: through its efficient filter system to remove dust, pollen and insects.

Principles of operation

In Heat Recovery mode, the Nano Air® alternates its operation with two cycles lasting 70 seconds each.

- Cycle I: Warm stale air is removed from the room.
- Cycle II: Fresh air is drawn in from outside, filtered and supplied into the room.

Product description

Compact heat recovery ventilation solution built into the wall to ventilate a room. Fitted with a ceramic heat exchanger, it renews air while recovering heat calories from warm stale air to supply fresh, pre-heated and filtered air.

Fields of application

Multi-occupancy residential housing, Individual residential housing, Refurbishment

Installation

- a round hole of diameter 180 mm must be drilled in the wall to fit the Nano Air® 50.
- the air duct is fitted into the wall using the polystyrene wedges supplied and builders foam.
- the telescopic end of the air duct must enable the outer ventilation grille to be fitted.
- the air duct must provide a minimum slope of 3 mm on the outside wall.

Main characteristics

- 3 speed modes available.
- airflow from 14 m³/h to 54 m³/h.
- 2 pollen filters.
- EC motor.
- ceramic heat accumulator, efficiency up to 88 %.
- control possible using remote control or buttons on product:
 - manually, with three-position selector switches to provide basic functions,
 - with the remote control, for more accurate control (night mode, humidity parameters).
- operating temperature limit:
 - ambient temperature from -20°C to +50°C, relative humidity up to 80%.
- 2-year warranty.

Consumables

Désignations	References
Pollen filter Nano® Air (pack of 2)	11023297
Finishing plate	11023298
Multi-function remote control Nano Air 50	11100002

11023290

Nano Air® 50 heat recovery CMEV for individual rooms

General data

References	Type of motor
11023290	EC

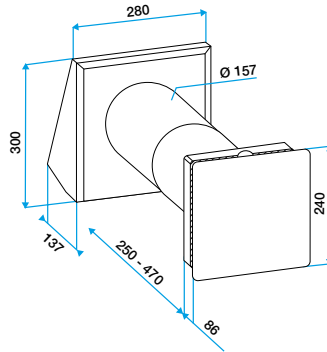

Nano Air 50

Electrical datas

References	Frequency (Hz)	Protection rating	Voltage (V)
11023290	50	IP24	230

Regulatory data

References	Ventilation energy class – Average climate
11023290	A

Installation visual 1

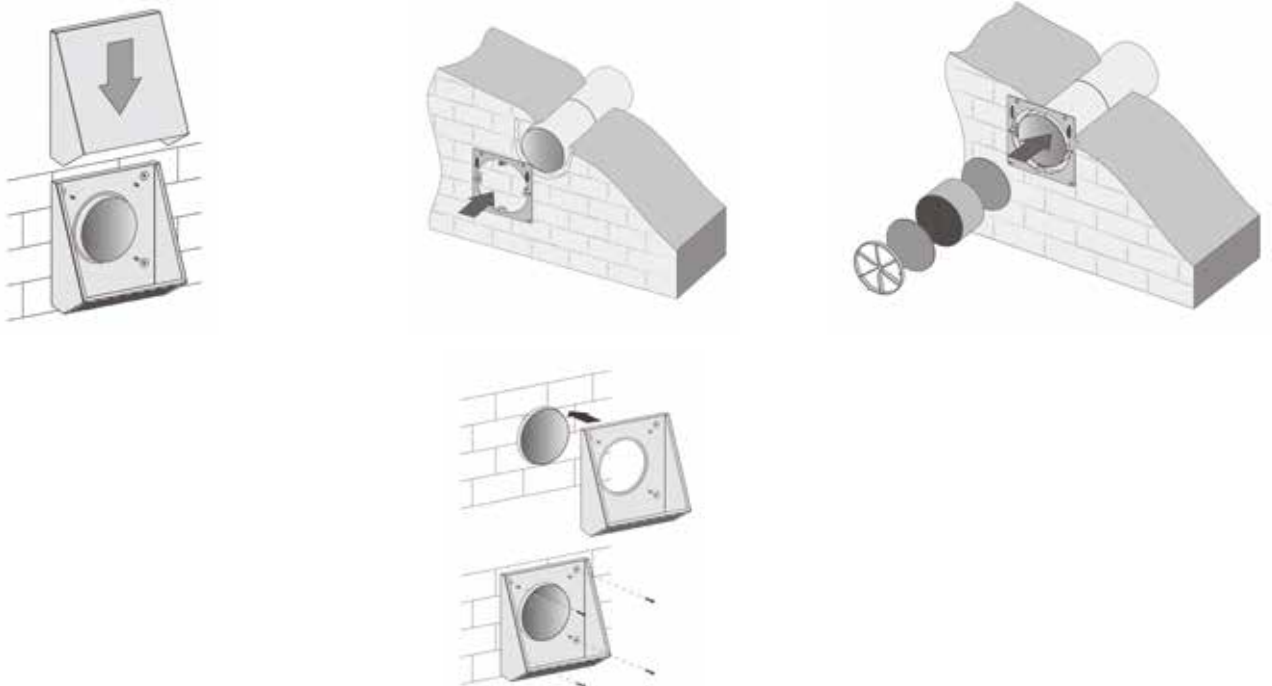

11023290

Nano Air® 50 heat recovery CMEV for individual rooms

Principe de fonctionnement

