

11039299

ProtectONE® R 21.0 EL 2SP

ProtectONE® R F400-120 2-speed is a smoke and heat exhaust box fan for commercial and industrial premises.



ProtectONE R 2SP with intake and outlet in line (EL)

PRODUCT BENEFITS

- easily adjusted airflow with the exclusive ProtectONE® Adapt system,
- can be fully dismantled as standard (except for insulated model),
- modular connection to discharge: left, right, vertical (except insulated model),
- backward curve impeller: smaller variation in airflow even if pressure losses vary.

REGLEMENTATIONS AND COMPLIANCES

PV CE number : 1812-CPR-1181

Principles of operation

When commanded by the FACP, the safety box will activate ProtectONE® R in smoke exhaust mode to extract smoke. The box will then switch to “default” mode, then “standby”.

Product description

ProtectONE® R 2SP is an F400-120 2-speed smoke and heat exhaust box fan for commercial and industrial premises. It features a direct-drive backward curve impeller. The exclusive ProtectONE® Adapt adjustment device can adjust the exhaust airflow easily at any time.

Fields of application

New, Refurbishment, Non-residential buildings

Installation

- indoors or outdoors,
- indoor installation: use thermal-acoustic insulation option (EN 12101-3),
- outdoor installation: use rain hood + bird screen,
- proximity switch supplied fitted and wired, with position contacts.

Main characteristics

- complies with CE marking 1812-CPR-1181,
- certified EFECTIS F400-120 as per EN12101-3,
- Free-wheel fan compliant with ErP 2018,
- airflow from 1000 to 21,000 m³/h,
- class F electric motor IP55,
- 3-phase 2-speed motor,
- built-in airflow adjustment device: ProtectONE® Adapt (patented), exclusive to ALDES (patented),
- centrifugal backward curve impeller coupled directly to motor,
- thermal insulation for installation in equipment room,
- 2 models: in-line output and 90° output.
- Scope:
 - removes smoke and hot gases in case of fire from any commercial building,
 - removes contaminated air in commercial and industrial premises,
 - removes pollutants in professional kitchens.

11039299

ProtectONE® R 21.0 EL 2SP

Supplementary characteristics

- 10 unit sizes for airflow from 1000 to 21,000 m³/h:
 - ProtectONE® R2.0 to ProtectONE® R5.0: Size 1,
 - ProtectONE® R6.5 to ProtectONE® R9.0: Size 2,
 - ProtectONE® R10.0 to ProtectONE® R21.0: Size 3,
 - ProtectONE® R2.0 to ProtectONE® R5.0: Size 1 EL,
 - ProtectONE® R6.5 to ProtectONE® R9.0: Size 2 EL,
 - ProtectONE® R10.0 to ProtectONE® R21.0: Size 3 EL.
- available options:
 - “All-in-One” solution: includes safety box, switch and pressure switch,
 - variable pressure switch 100 - 1000 Pa (1 pressure switch for each smoke and heat exhaust speed),
 - choice of outlet position: LH/RH access on EL model,
 - thermal insulation approved for installation in equipment rooms,
- accessories:
 - square/circular adjustment plate for intake,
 - rain hood anti-bird visor on outlet,
 - rectangular and circular flexible sleeve,
 - anti-vibration mountings,
 - backdraft damper.

Accessories

| Désignations | References |
|---|------------|
| Rectangular flexible sleeve for air inlet T3 ProtectONE® R EL | 11039180 |
| Rectangular flexible sleeve for air outlet T3 ProtectONE® R | 11039183 |
| ProtectONE R backdraft damper T3 | 11039186 |
| Outlet flange T3 ProtectONE® R | 11039165 |
| Rectangular/circular adapter Ø 710 for air intake T3 ProtectONE® R EL | 11039171 |
| Rectangular/circular adapter Ø 710 for air outlet T3 ProtectONE® R | 11039174 |
| Pressure switch kit 20-300 Pa ProtectONE® R | 11091097 |
| Pack of 6 anti-vibration mountings | 11039348 |

General data

| References | Type of motor | Type of impeller |
|------------|---------------|------------------|
| 11039299 | AC | Backward curve |

Dimensional data

| References | A (mm) | B (mm) | C (mm) | D (mm) | H (mm) | I (mm) | L (mm) | Flange (mm) | Insulation (mm) | Weight (kg) |
|------------|--------|--------|--------|--------|--------|--------|--------|-------------|-----------------|-------------|
| 11039299 | 510 | 795 | 795 | 795 | 1020 | 965 | 1430 | I+20 | L+50 H+25 | 249 |

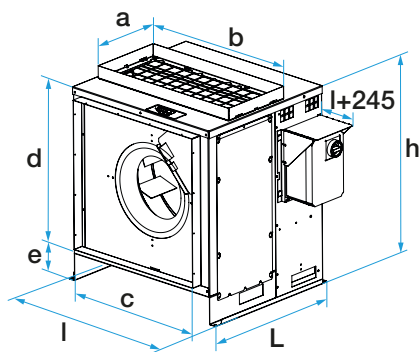

Encombrement ProtectONE® R 2V (mm)

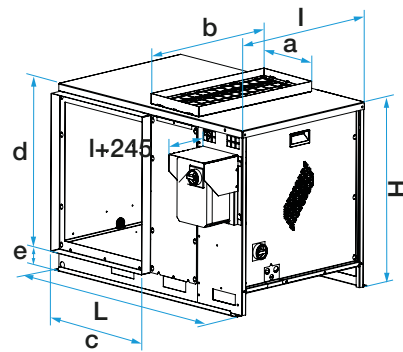

Encombrement ProtectONE® R EL 2V (mm)

11039299 ProtectONE® R 21.0 EL 2SP

Electrical datas

| References | Id/In | Rated current (A) | Voltage (V) | Number of poles | Power (kW) |
|------------|---------|-------------------|-------------|-----------------|------------|
| 11039299 | 7.8/7.4 | 13,7/6,96 | 400 | 04-june | 6/2,2 |

Installation visual 1



Choix de raccordement au refoulement ProtectONE R (modèle 90°)

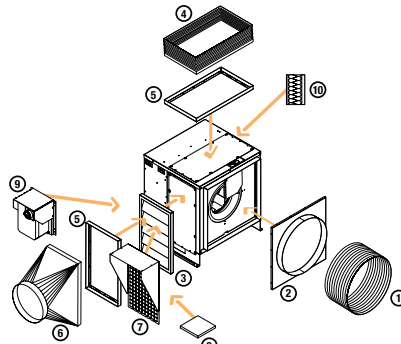

Options et accessoires ProtectONE® R (Modèle 90°)

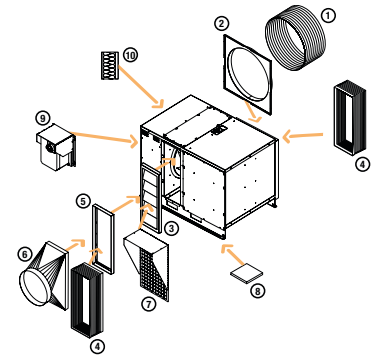

Options et accessoires ProtectONE® R EL

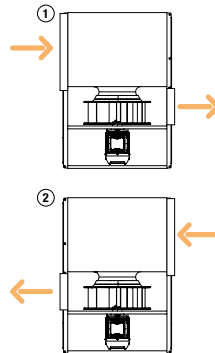

Choix de raccordement gauche/droite ou droite/gauche sur ProtectONE R EL

Curve

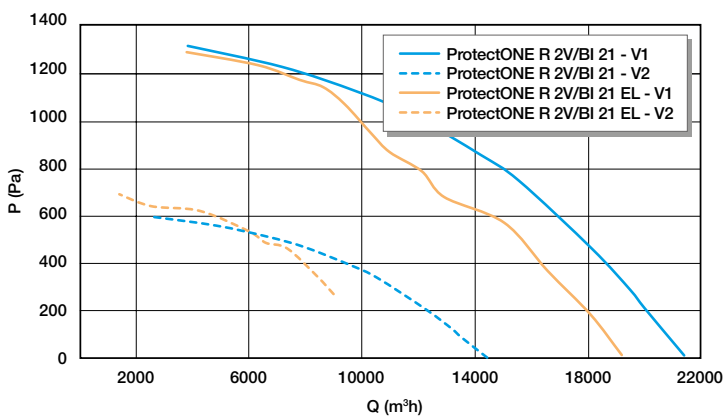

Aeraulic properties ProtectONE® R 21.0 EL - 2SP - BI