

**Individual ventilation distribution box fan****11039556**  
**ProtectONE® TR 400 2SP BI**

ProtectONE® TR 2SP Independent windings is an F400-120 smoke and heat exhaust box fan for commercial and industrial premises.

**PRODUCT BENEFITS**

- easily adjusted airflow with the exclusive ProtectONE® Adapt system,
- can be fully dismantled as standard (except for insulated model),
- thermal insulation for installation in equipment room,
- backward curve impeller: smaller variation in airflow even if pressure losses vary.

**REGULATIONS AND COMPLIANCES**

PV CE number : 1812-CPR-1548

**Principles of operation**

When commanded by the FACP, the safety box will activate ProtectONE® T in smoke exhaust mode to extract smoke. The box will then switch to “default” mode, then “standby”.

**Product description**

ProtectONE® TR 2SP - Independent windings is an F400-120 smoke and heat exhaust box fan for commercial and industrial premises. It features a belt-driven backward curve impeller. The ProtectONE® Adapt adjustment device can adjust the exhaust airflow easily at any time.

**Fields of application**

New, Refurbishment, Non-residential buildings

**Installation**

- indoors or outdoors,
- indoor installation: use thermal-acoustic insulation option (EN 12101-3),
- outdoor installation: use rain hood + bird screen,
- proximity switch supplied fitted and wired, with position contacts.

**Main characteristics**

- complies with CE marking 1812-CPR-1548,
- certified EFECTIS F400-120 as per EN12101-3,
- safety box compliant with NF standards (NF S61-937-1, NFS61937-9, NF 537),
- belt-driven exhaust box fan,
- 4 models for airflow from 1,000 to 35,000 m<sup>3</sup>/h,
- 2-speed motor, independent windings from 1.1 kW to 20 kW,
- balanced backward curve impeller,
- adjustable pulley,
- class F electric motor IP55,
- galvanised steel casing, can be dismantled as standard,
- motor access panel adjustable on site,
- proximity switch fitted in factory,
- airflow adjustment device built into unit: ProtectONE Adapt (patented system), exclusive to ALDES (option),
- ProtectONE® TR 2-speed IW can extract:
  - smoke and hot gases in case of fire in all non-residential buildings,
  - stale air in non-residential and industrial buildings,
  - pollutants in professional kitchens.

Individual ventilation distribution box fan

## 11039556 ProtectONE® TR 400 2SP BI

### Supplementary characteristics

- accessories:
  - square/circular adjustment plate for intake,
  - rain hood anti-bird visor on outlet,
  - rectangular and circular flexible sleeve,
  - rectangular/circular flexible adapter part on outlet,
  - anti-vibration mountings,
  - backdraft damper,
  - rain hood + grille,
  - outlet flange,
  - AXONE 1SP safety box, 1-speed progressive start,
  - AXONE 2SP safety box, 2-speed smoke exhaust and comfort + smoke exhaust.
- available options:
  - "All-in-One" solution: safety box + switch + pressure switch installed and wired in factory,
  - choice of motor access panel,
  - horizontal or vertical outlet,
  - thermal + acoustic insulation certified 12101-3 for installation in equipment rooms,
  - variable pulley,
  - ProtectONE® Adapt (patented): rapid airflow adjustment.

### Accessories

Description	Variants
ProtectONE® T vertical outlet grille 400	11039626
Pack of 6 anti-vibration mountings	11039348
RECT SLEEV INTAKE 400 PROTECTONE T	11039496
REC SLV INT250 400 PROTECTONE T	11039567
REC.CIR ADA INT D710 400 PROTE	11039576
RAIN HOOD GRILLE 400 PROTECTONE T	11039586
DISCHARGE FLANGE 400 PROTECT T	11039596
FLEXIBLE ADAPTER DISCHARGE 400 PROTECTONE T	11039606
NON-RETURN 400 PROTECTONE T	11039616

### General data

Variants	Type of motor	Type of impeller
11039556	AC	Backward curve

### Dimensional data

Variants	A (mm)	A.R (mm)	B (mm)	B.R (mm)	C (mm)	D (mm)	E (mm)	F (mm)	G (mm)	H (mm)
11039556	1608	600	1213	43	1141	954	411	145	950	509

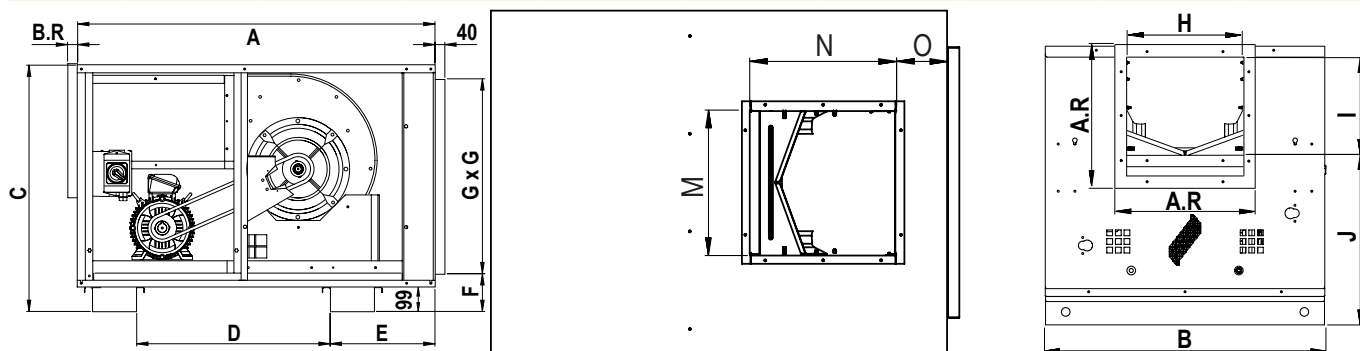

## Individual ventilation distribution box fan

# 11039556

## ProtectONE® TR 400 2SP BI

### Electrical datas

Variants	Voltage (V)	Id/In	Max. current (A)	Rated current (A)	Number of poles	Power (kW)	Caractéristiques électriques
11039556	400	7.8/7.4-7/4	14,85/7,65-24,2/9,61	13,5/6,96-22/8,74	04-june	6/2,2 - 10/3,3	<table><tr>

### Installation

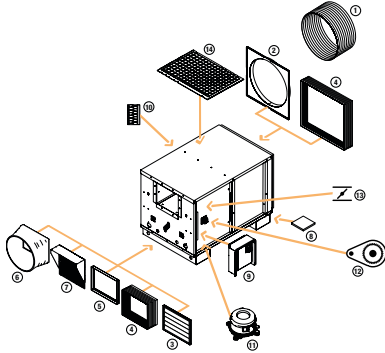

Accessoires ProtectONE T



Schéma en vue de dessus, avec accès gauche



Schéma en vue de dessus, avec accès droit

### Curve

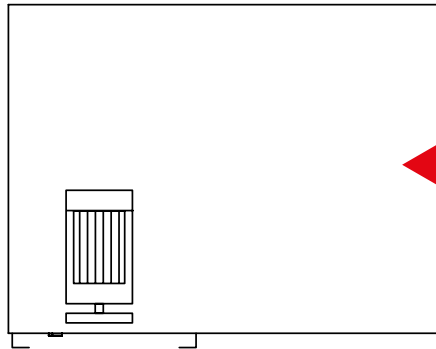

> curves as per NF EN ISO 5801:

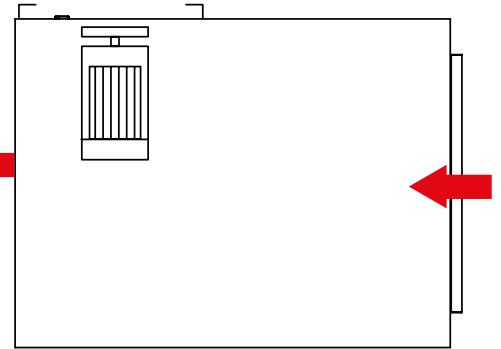
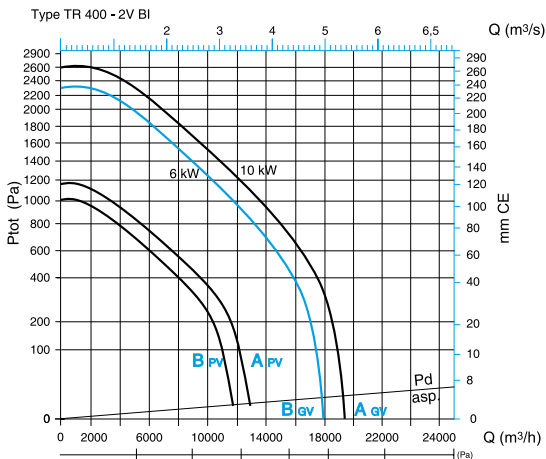
- ducted intake, open outlet,
  - Ptot: Total pressure,
  - Pd intake. : dynamic pressure in duct on intake,
  - ΔP ducted outlet: higher pressure with ducted outlet rather than open outlet.
- > see ProtectONE TA 225 for explanations of curves.

I (mm)	J (mm)	M (mm)	N (mm)	O (mm)	Weight (kg)
431	669	507	507	180	337