

11039547

ProtectONE® TR 450 2SP DAH

ProtectONE® TR 2SP is an F400-120 smoke and heat exhaust box fan for commercial and industrial premises.



Smoke exhaust unit ProtectONE T

PRODUCT BENEFITS

- easily adjusted airflow with the exclusive ProtectONE® Adapt system,
- can be fully dismantled as standard (except for insulated model),
- thermal insulation for installation in equipment room,
- backward curve impeller: smaller variation in airflow even if pressure losses vary.

REGLEMENTATIONS AND COMPLIANCES

PV CE number : 1812-CPR-1548

Principles of operation

When commanded by the FACP, the safety box will activate ProtectONE® T in smoke exhaust mode to extract smoke. The box will then switch to “default” mode, then “standby”.

Product description

ProtectONE® TR 2SP - Dahlander is an F400-120 smoke and heat exhaust box fan for commercial and industrial premises. It features a belt-driven backward curve impeller. The ProtectONE® Adapt adjustment device can adjust the exhaust airflow easily at any time.

Fields of application

New, Refurbishment, Non-residential buildings

Installation

- indoors or outdoors,
- indoor installation: use thermal-acoustic insulation option (EN 12101-3),
- outdoor installation: use rain hood + bird screen,
- proximity switch supplied fitted and wired, with position contacts.

Main characteristics

- complies with CE marking 1812-CPR-1548,
- certified EFECTIS F400-12 as per EN12101-3,
- safety box compliant with NF standards (NF S61-937-1, NFS61937-9, NF 537),
- belt-driven exhaust box fan,
- 8 models for airflow from 1,000 to 35,000 m³/h,
- Dahlander 2-speed motor generating 1.5 kW to 20 kW,
- balanced backward curve impeller,
- adjustable pulley,
- class F electric motor, IP55,
- galvanised steel casing, can be dismantled as standard,
- motor access panel adjustable on site,
- proximity switch fitted in factory,
- built-in airflow adjustment device: ProtectONE® Adapt (patented system) exclusive to Aldes (optional),
- ProtectONE® TR 2SP DAH removes:
 - smoke and hot gases in case of fire from any commercial building,
 - contaminated air in commercial and industrial premises,
 - pollutants in professional kitchens.

11039547 ProtectONE® TR 450 2SP DAH

Supplementary characteristics

- accessories:
 - square/circular adjustment plate for intake,
 - rain hood anti-bird visor on outlet,
 - rectangular and circular flexible sleeve,
 - rectangular/circular flexible adapter part on outlet,
 - anti-vibration mountings,
 - backdraft damper,
 - rain hood + grille,
 - outlet flange,
 - AXONE 1SP safety box, 1-speed progressive start,
 - AXONE 2SP safety box, 2-speed smoke exhaust and comfort + smoke exhaust.
- available options:
 - "All-in-One" solution: safety box + switch + pressure switch installed and wired in factory,
 - choice of motor access panel,
 - horizontal or vertical outlet,
 - thermal + acoustic insulation certified 12101-3 for installation in equipment rooms,
 - variable pulley,
 - ProtectONE® Adapt (patented): rapid airflow adjustment.

Accessories

Désignations	References
ProtectONE® T vertical outlet grille 450	11039627
Flexible connector - Ø 800	11096931
Pack of 6 anti-vibration mountings	11039348
RECT SLEEV INTAKE 450 PROTECTONE T	11039497
RECT DIS SLV 450 PROTECTONE T	11039565
REC.CIR ADA INT D800 450 PROTE	11039577
RAIN HOOD GRILLE 450 PROTECTONE T	11039587
DISCHARGE FLANGE 450 PROTECT T	11039597
FLEXIBLE ADAPTER DISCHARGE 450 PROTECTONE T	11039607
NON-RETURN 450 PROTECTONE T	11039617

General data

References	Type of motor	Type of impeller
11039547	AC	Backward curve

Dimensional data

References	A (mm)	A.R (mm)	B (mm)	B.R (mm)	C (mm)	D (mm)	E (mm)	F (mm)	G (mm)	H (mm)
11039547	1758	650	1373	43	1211	954	561	155	1000	571

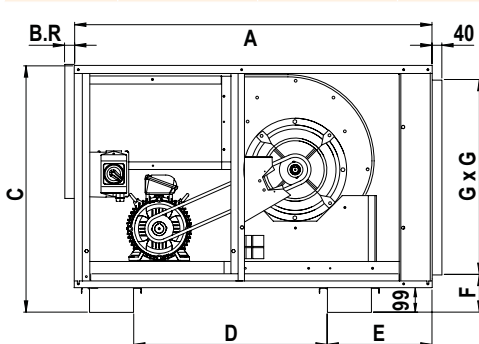

Encombrement (mm) - vue de profil

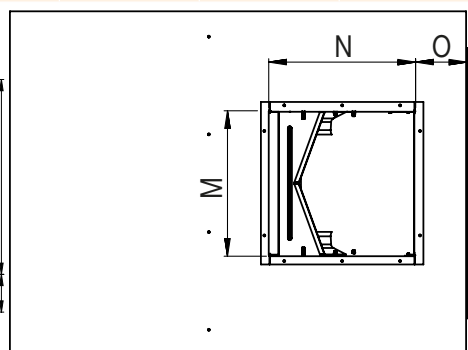

Encombrement (mm) - vue de dessus

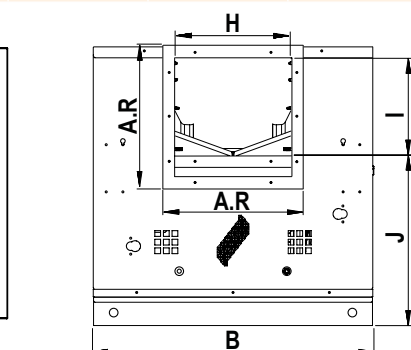

Encombrement (mm) - vue de face

11039547 ProtectONE® TR 450 2SP DAH

Electrical datas

References	Id/In	Max. current (A)	Rated current (A)	Voltage (V)	Number of poles	Power (kW)
11039547	7.9/4.2-7/4.3	18,15/5,56-23,1/7,7	16,5/5,06-21/7	400	04-aug	7,2/1,8 - 11/3

Installation visual 1

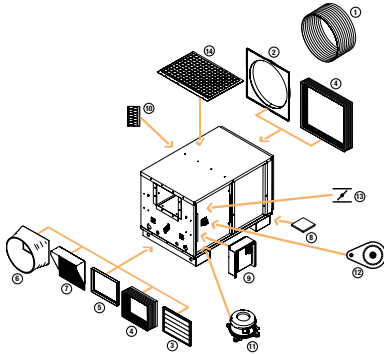

Accessoires ProtectONE T



Schéma en vue de dessus, avec accès gauche



Schéma en vue de dessus, avec accès droit

Curve

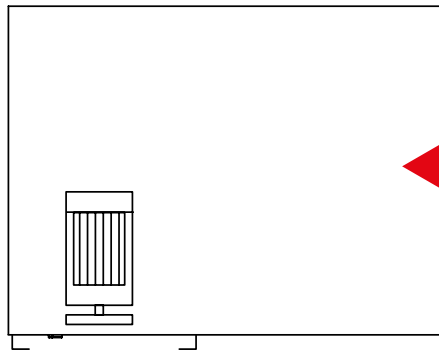

Aeraulic properties ProtectONE® TR 450 - 2SP - DAH

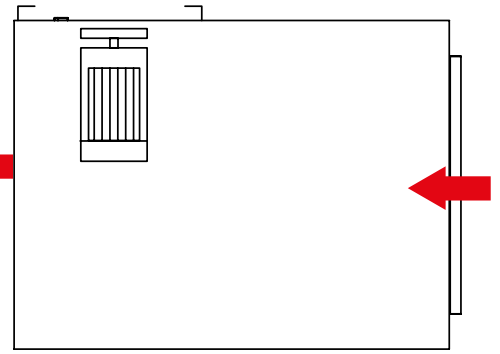
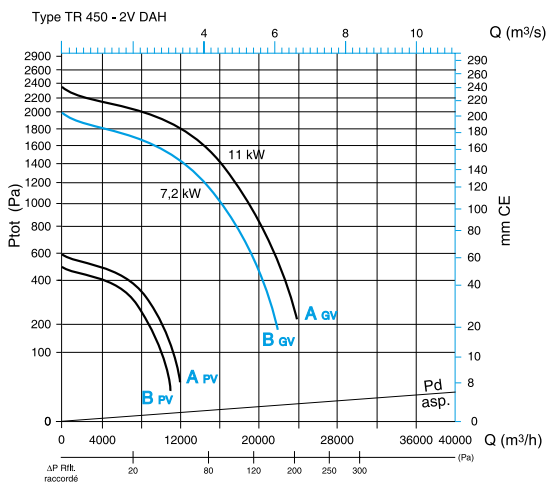
> curves as per NF EN ISO 5801:

- ducted intake, open outlet,
 - Ptot: Total pressure,
 - Pd intake. : dynamic pressure in duct on intake,
 - ΔP ducted outlet: higher pressure with ducted outlet rather than open outlet.
- > see ProtectONE TA 225 on use of curves.

I (mm)	J (mm)	M (mm)	N (mm)	O (mm)	Weight (kg)
485	685	569	569	200	404