

Wall grille**11050073**
SC102D F3 800X200

The SC 102 D steel wall grille enables air extraction on all ventilation and air-conditioning systems.



SC102D F3 800X200

PRODUCT BENEFITS

- adjustable vanes,
- easy to install / remove.

Principles of operation

The SC 102 D dual-deflection has individually dirigible horizontal and vertical vanes to adjust the air supply level in a room.

Product description

The SC 102 D is a steel dual deflection wall-mounted grille, white paint coating, with individually adjustable, movable horizontal rear and vertical front vanes.

Fields of application

New, Refurbishment, Non-residential buildings

Installation

- wall installation,
- concealed F3 attachment using friction clips.

Main characteristics

- Steel with white epoxy paint finish, RAL 9003 30% matt,
- horizontal fins at the rear and vertical fins at the front, individually adjustable, 20 mm pitch
- dimensions from 75 x 75 to 1200 x 600 mm with increments of 25 mm in length & height.

Accessories

Désignations	References
Adapter F4 800X200	11053774
PLEN. ME F3 800X200/2XD200 PC	11053681
MTF3 800X200/2XD200 PLENUM PA	11053651
RECT DAMPER SGS 800X200	11053254
ME Plenum F3 800X200/2xD200 PC cfg	11053568
MT Plenum F3 800X200/2xD200 PA cfg	11053494

General data

References	Type of finish	Colour
11050073	Epoxy paint	Lagoon blue

Wall grille

11050073
SC102D F3 800X200

Dimensional data

References	H (mm)	L (mm)
11050073	200	800

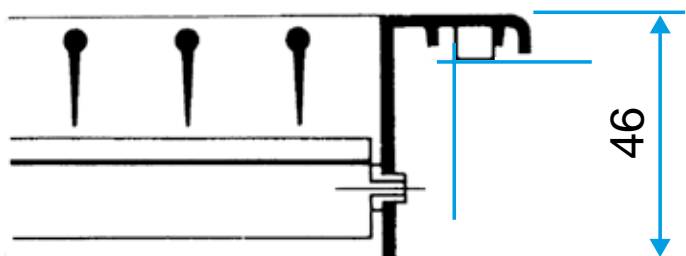

Grille SC 102 D seule

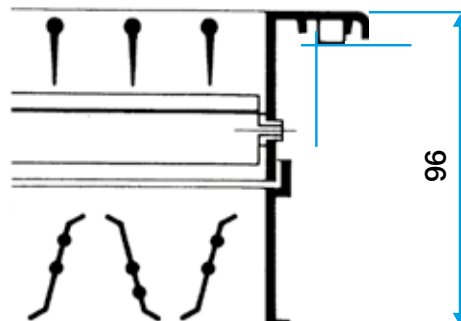

Grille SC 102 D avec registre AGB ou SGS monté

Airflow data

References	Comfort airflow for $L_w < NR 25$ (m ³ /h)
11050073	1500