

Pressed grille

11050180

SR 356 F1 203X102

The SR 356 pressed wall grille is used for air supply. It features a damper to adjust the airflow.



SR 356 F1 203X102

PRODUCT BENEFITS

- adjustable airflow,
- diffusion in two directions.

Principles of operation

The pressed wall grille features inclined vanes and is used for air supply. It is also possible to adjust the airflow using the built-in slotted damper.

Product description

The SR 356 is a pressed steel grille. Its inclined fixed vanes are divided into two sections, to diffuse to the right and to the left. It features a damper to adjust the airflow.

Fields of application

New, Refurbishment, Non-residential buildings

Installation

- for installation on wall,
- visible screw attachment in frame.

Reference arguments

- Single deflection terminal with vertical vanes, 20° incline to left and right, 8.5 mm pitch.
- Pressed steel.
- Steel finish, epoxy paint RAL 9010 white.
- Visible screw attachment in frame.

Main characteristics

- steel - white epoxy painted finish, RAL 9003 30%,
- vertical vanes, 20° incline to left and right, 8.5 mm pitch.
- multiple-vane damper with parallel action built into terminal.

General data

References	Type of finish	Colour
11050180	Epoxy paint	Lagoon blue

Pressed grille

11050180

SR 356 F1 203X102

Dimensional data

References	H (mm)	H1 (mm)	H2 (mm)	L (mm)	L1 (mm)	L2 (mm)
11050180	102	144	100	203	241	200

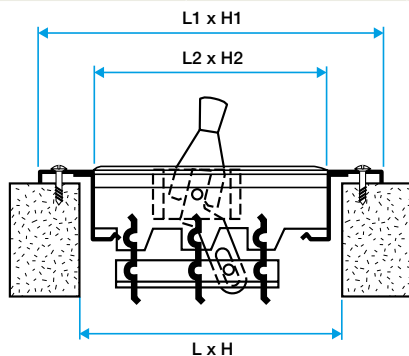

Grille SR 356



Grille SR 356

Airflow data

References	Comfort airflow for Lw < NR 30
11050180	150