

Swirl jet diffuser**11003365****TWISTED® 850 D200 AxB 625x625**

The TWISTED® 850 is a high-induction swirl jet diffuser for air diffusion in commercial buildings.



TWISTED 850 D200 AxB 625x625



TWISTED 850 D200 AxB 625x625

PRODUCT BENEFITS

- ideal for variable-airflow systems,
- excellent mixing rate: Exclusive Aldes patent,
- compatible with AldesArchitect® range.

Principles of operation

The TWISTED® 850 diffuser is designed to be installed in place of a standard ceiling tile, providing high-induction fixed diffusion with a swirl air jet across a wide range of airflows in a single diffuser.

Product description

The TWISTED® 850 is a high-induction swirl jet diffuser for air diffusion in ventilation or air conditioning systems in commercial buildings with high mixing rates. It is ideal for air supply with large temperature differences and low ceiling heights, and for variable-airflow systems (e.g. ducted fan systems). It replaces a 600 x 600 mm or 675 x 675 mm suspended ceiling tile. It is suitable for T-bar and Fine Line frame systems. It is also available in insulated and return air versions, with and without filter. Available in a standard epoxy coating in RAL 9003 matt 30% gloss or as per the RAL chart. The AldesArchitect® range of finishes is available for this diffuser.

Fields of application

Non-residential buildings

Installation

The TWISTED® 850 diffuser is installed on the ceiling. It must be attached to the concrete slab using the tabs on the plenum.

Reference arguments

- Twisted return air diffuser.
- Installed in suspended ceiling in place of 625x625 mm panel with T-Bar or FineLine suspension systems.
- Wide range of airflow settings: 150 to 600 m³/h.
- RAL 9003 white 30% or any other colour of architect's choice.
- D200 connection.
- G2 filter (ISO coarse 40%)
- Easy to clean due to opening disc.
- Plenum included with acoustic or thermal-acoustic insulation option.

Main characteristics

- high induction diffusion with swirl air jet,
- system offers high mixing rate,
- ideal for cold and hot supply air with high T° differences under low ceiling heights,
- ideal for variable-airflow systems,
- designed to replace a suspended ceiling tile,
- painted steel diffuser cone and central disc,
- steel compensation plate suitable for 600 x 600 mm or 675 x 675 mm ceiling tiles with «Tbar» or «Fine-Line» frame systems,
- cylindrical galvanised steel plenum for direct attachment to circular duct Ø 200 supplied as standard,
- finish:
 - epoxy coating RAL 9010 white matt 30%,
 - AldesArchitect®.
- attachment to concrete ceiling using the bracket on the plenum.

Swirl jet diffuser

11003365

TWISTED® 850 D200 AxB 625x625

Supplementary characteristics

- accessories:
 - G2 elliptical flat filter (ISO coarse 40%) supplied with return diffuser,
- option:
 - sound-proofing,
 - thermal insulation
 - bridge system F7 attachment.

Consumables

Désignations	References
Replacement G2 filter for TWISTED® (pack of 5) D200	11053949
Replacement G2 filter for TWISTED® (pack of 5) D250	11053981

Options

base
9010
ACOU
DECORHC
FILTR
PEINTHC
RAL1
RAL2
RAL4
THER

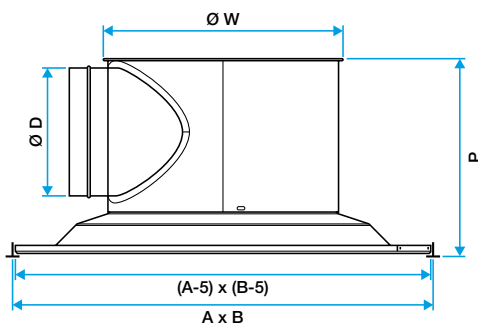

Diffuseur Twisted 850 pour dalles carrées

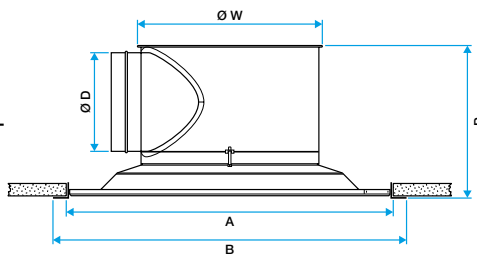

Diffuseur Twisted 850 pour plafond staff ou BA13

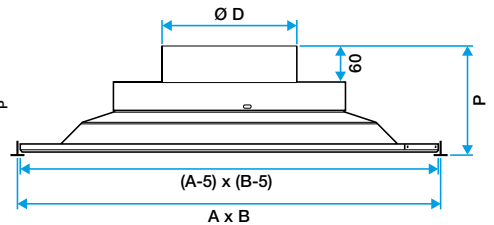

Diffuseur Twisted 850 reprise vrac pour dalles carrées

Installation visual 1

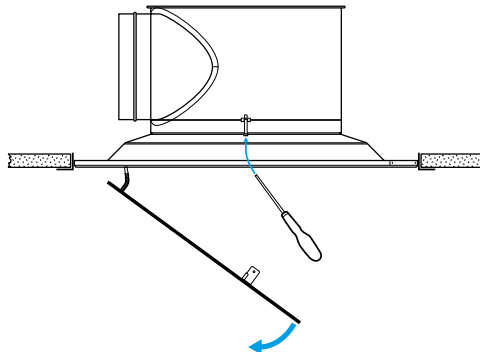

1