

11021383

VELONE® 13 - 6/12T 2.2/0.55 kW

VELONE F400 - 13.0 - 3-Phase is an F400-120 class smoke and heat exhaust roof fan for commercial, industrial and multi-occupancy residential buildings.



VELONE

PRODUCT BENEFITS

- accessories protected against impact + weather by metal body,
- factory-wired electrical accessories protected against impacts and inclement weather,
- pressure switch connected in factory.

REGLEMENTATIONS AND COMPLIANCES

PV CE number : 1812_CPR_2014

Principles of operation

When commanded by the FACP, the safety box will activate the VELONE F400 smoke and heat exhaust roof fan in smoke exhaust mode to extract smoke. The box will then switch to "default" mode, then "standby".

Product description

VELONE F400 - 13.0 - 3-Phase is an F400-120 class smoke and heat exhaust roof fan for commercial, industrial and multi-occupancy residential buildings. Its clever design means it can deliver airflows up to 27,000 m³/h without enlarging the base unit dimensions. For this range, Aldes proposes an "All-in-One" solution with a safety box pre-fitted in the factory.

Fields of application

Multi-occupancy residential housing, New, Refurbishment, Non-residential buildings

Installation

- outdoor installation directly on duct or on flat roof base (accessory).

Main characteristics

- F400-120 classification as per EN 12101-3,
- CE certificate-compliant non-return damper and rain hood optional accessories,
- airflow from 100 to 1,200 m³/h at 200 pa,
- pressure switch can be connected in factory,
- galvanised steel motor bracket and base unit,
- ABS hood fastened by 4 high-helix lead screws,
- galvanised steel backward curve impeller,
- class F electric motor IP55,
- galvanised steel protective screen,
- pivot shaft for easy cleaning,
- can replace any Velone roof fan delivered between 1998 and 2007 due to same base unit dimensions.
- type: 13-6T | Nbr poles: 6 | U (V): 400 | P (kW): 2.2 | f (Hz): 50 Hz | I nom. (A): 5.22 | Id/In: 6.4 | EEL: IE3,
- type: 13-8T | Nbr poles: 8 | U (V): 400 | P (kW): 1.1 | f (Hz): 50 Hz | I nom. (A): 3.3 | Id/In: 4.6 | EEL: IE3,
- type: 13-6/8T | Nbr poles: 6/8 | U (V): 400 | P (kW): 2.2/1.3 | f (Hz): 50 Hz | I nom. (A): 5.96/4.36 | Id/In: 6.0/4.5 | EEL: EI3,
- type: 13-6/12T | Nbr poles: 6/12 | U (V): 400 | P (kW): 2.2/0.55 | f (Hz): 50 Hz | I nom. (A): 5.87/2.4 | Id/In: 6.3/2.8 | EEL: EI3.

11021383

VELONE® 13 - 6/12T 2.2/0.55 kW

Supplementary characteristics

- available accessories: (fire tested and approved in CE certificate):
 - lab-tested IPX4 rain hood kit = water splashes from any direction (for smoke and heat exhaust only),
 - sheet metal rain hood kit (for smoke and heat exhaust and ventilation),
 - backdraft damper,
 - vertical outlet kit,
 - sealing frame or frame mounted on duct,
 - pivot shaft,
 - flat roof or sloping roof base,
 - outlet blanking plug.
- electrical accessories:
 - single-phase voltage regulator,
 - 3-phase autotransformer,
 - frequency inverter.
- available options:
 - pressure switch connected, fixed and protected,
 - proximity switch wired, fixed and protected,
 - "All-in-one" solution (not available in single-phase version): Safety box supplied wired, pressure switch and main switch supplied and wired.
 - EPOXY paint finish

Accessories

Désignations	References
Backdraft damper 8.5/13	11021262
Rain hood kit IPX4 8.5/13	11021287
Vertical outlet kit VELONE 8.5 / 13.0	11021368
VELONE F400-120 pivot pin - Model 8.5/13.0 - base 834 mm	11021071
Double reset box AXONE / SOS VELONE	11057200
VELONE seal-in frame 8.5/13.0	11021292
Duct-mounted frame VELONE 8.5/13.0	11021297
Flat roof base H330 VELONE F400-120 8.5/13.0 - 834 mm	11021082
Roof base 8.5/13	11021087
Roof base H500 8.5/13.0	11021142

Options

base
21275
21276
21279
21280
21282

General data

References	Type of motor	Type of impeller
11021383	AC	Backward curve

11021383 VELONE® 13 - 6/12T 2.2/0.55 kW

Dimensional data

References	A (mm)	B (mm)	F (mm)	H (mm)	J (mm)	K (mm)	Ø D (mm)	Weight (kg)
11021383	834	820	794	355	218	833	419	131

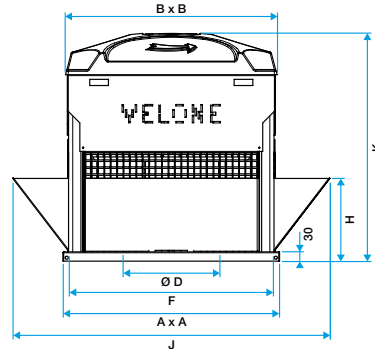

Encombrement (mm)

Electrical datas

References	Frequency (Hz)	Id/In	Rated current (A)	Voltage (V)	Number of poles	Power (kW)
11021383	50/60	07/03/2022 00:00:00	6,4/2,6	400	06-dec	2,2/0,55

Installation visual 1

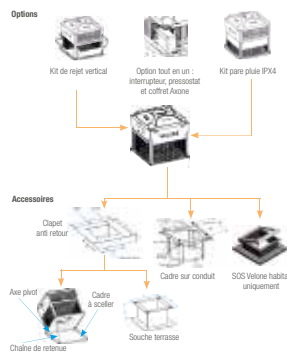

Vue des accessoires compatibles avec VELONE

Curve

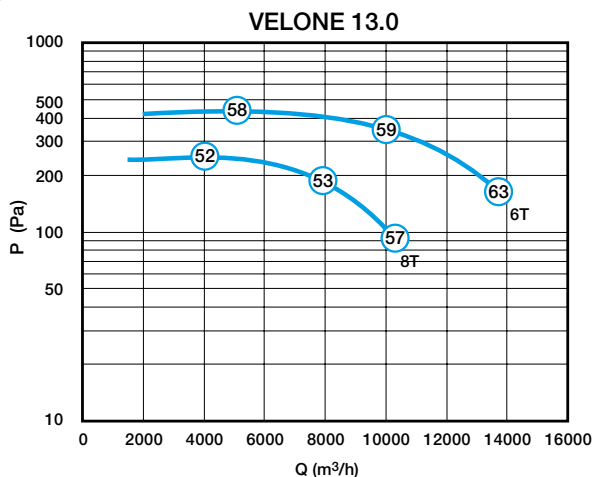

> graphs as per NF EN ISO 5801, ducted intake (Ø 560 mm),
 > pressure values indicated on graphs are static pressure values,
 > circled values = global acoustic pressure level radiated in free field at 6 m, weighted A (Lpm6 (dB (A))).

Aeraulic and acoustic properties VELONE 13 - 6/12T 2.2/0.55 KW