

## Air handling unit

# 11058414

## VEX320C-2

The VEX 300 C ceiling units are very compact and quiet, ideal for installation in suspended ceilings.



### PRODUCT BENEFITS

- for suspended ceiling installation,
- very compact with high output,
- ultra quiet.

### REGLEMENTATIONS AND COMPLIANCES

Eurovent Certification no. : 10.12.505

### Principles of operation

The VEX 300 C brings fresh, filtered air into the building and recovers heat from exhaust air using its high-efficiency heat exchanger. The incoming air can be heated and/or cooled using a comprehensive range of coils.

### Product description

VEX 300 C ceiling units are very compact, making them ideal for installation above suspended ceilings, etc. Two-door variations allow for either vertical or horizontal opening, ideal for servicing requirements with different types of suspended ceilings and where there is limited space available. The optimised design delivers ultra-low sound levels. VEX 300 C is available as a LEFT or RIGHT version - with two motor sizes.

### Fields of application

New, Refurbishment, Non-residential buildings

### Installation

- indoor (false-ceiling),
- circular spigots,
- right or left access.

## Air handling unit

11058414  
VEX320C-2

## Main characteristics

- 4 VEX300C models up to 1 490 m<sup>3</sup>/h,
- monobloc units,
- freestanding construction with double skinned panels,
- external finish: Aluzinc AZ185: corrosion class C4,
- 49 mm mineral wool insulation, density 65kg/m<sup>3</sup>,
- EN1886 values: D2, L2/L2, T2, TB3, F8,
- EC motor with high performance backward curved impeller,
- easy access & maintenance: sliding or hinge-mounted doors,
- choice of positioning of controls,
- highly efficient heat recovery heat exchanger (Eurovent AAHE),
- modulated Bypass,
- choice of filters for guaranteed air quality: flat ISO ePM10 50% (M5) or ISO ePM160% (F7) filters (ask us about other types of filter/pre-filter),
- Integrated switch,
- EXact2 controls:
  - constant speed,
  - multi-speed,
  - constant pressure,
  - 0-10V.
- configuration and monitoring via:
  - wired remote control,
  - option: Webserver and BMS communications via Modbus RTU / RS485, BACnet MSTP / BACnet IP protocols,
  - option: Webserver and BMS communications via a bridge to Modbus TCP/IP or LON protocols.

## Accessories

Désignations	References
Motor Sfa-S2 On/Off 24/230V	11055045
Standalone detector trip device 230/24V	11906103
Smoke sensor	11058417

## Consumables

Désignations	References
Filter M5 Coarse 85% VEX320C	11101506
F7 filter PM1 55% VEX320C	11101508

## Associated services

Commissioning

## General data

References	Insulation density (kg/m <sup>3</sup> )	Thickness of insulation (mm)	Available filters	Max. Total efficiency (A-D) (%)	Efficiency level requirements	ECO efficiency level during optimal operating point	EC motor	Total pressure (Pa)	RPM during optimal operating point	Connection direction
11058414	65	50	flat ISO ePM10 50% (M5) or ISO ePM1 60% (F7) filters (ask us about other types of filter/pre-filter)	0,601	62N (2015)	73,7N	Med motorcontroller (VSD)	733 Pa	3735	Ceiling

Air handling unit

## 11058414

### VEX320C-2

#### Dimensional data

References	A (mm)	B (mm)	C (mm)	E (mm)	F (mm)	Ø connection (fresh air or exhaust) (mm)	Ø connection (discharge or air supply) (mm)	Weight (kg)
11058414	995	440	1135	1385	540	315	315	131

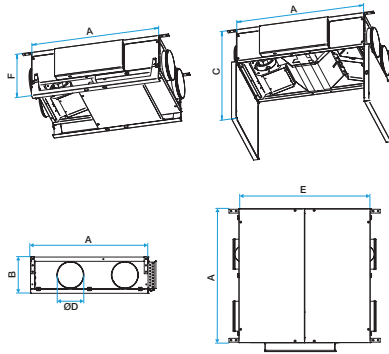

Dimensions VEX300C

#### Airflow data

References	Minimum airflow	Airflow (m³/h)	Max. airflow (m³/h)
11058414	90	1.355 m³/h	1260

#### Thermal data

References	Max. exchanger output (%)	Max. current absorbed (kW)
11058414	94	5,3

#### Electrical datas

References	Frequency (Hz)	Protection rating	Max. current consumption SINGLE-PHASE 230 V (A)	Max. electrical output of unit (kW)	Unit voltage (V)
11058414	50	IP20	5,3	1,2	230

#### Regulatory data

References	Test values as per standard EN 1886
11058414	D1, L1, L1, F9, T2, TB3

#### Curve

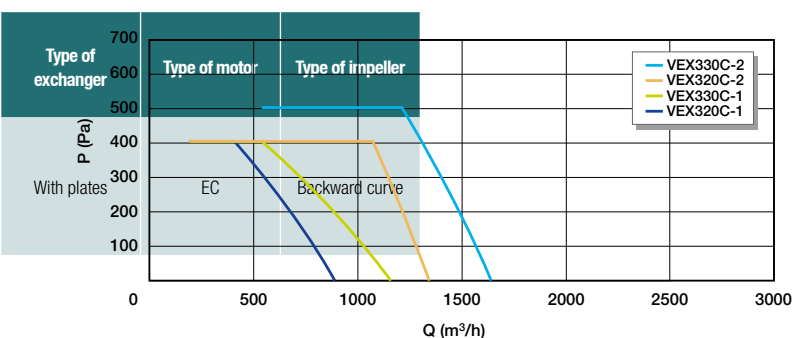

Aerologic characteristics VEX300C