

## Air handling unit

11060828  
VEX430

VEX400 is an economical AHU solution delivering good indoor air quality and a high level of comfort while limiting energy losses in the building.



VEX400



VEX400 ouverte

## PRODUCT BENEFITS

- cost-effectiveness,
- performance and efficiency,
- coverage of low airflows,

## Principles of operation

VEX400 brings fresh, filtered air into the building and recovers heat from exhaust air using its high-efficiency heat exchanger. The incoming air can be heated and/or cooled using a full range of coils.

## Product description

VEX400 is the ideal, economical and robust solution for small non-residential buildings. Thanks to its heat exchanger, its range of filters and coils, building occupants enjoy good indoor air quality (up to ePM1 60%) alongside high thermal and acoustic comfort. VEX400 also restricts energy losses to a minimum (up to 90% efficiency on Eurovent AAHE-certified heat exchanger).

## Fields of application

New, Refurbishment, Non-residential buildings

## Installation

- equipment rooms / flat roofs,
- indoors / outdoors,
- in-line duct connections,
- rectangular connectors (circular adapters available as accessories),
- choice of utility connections side - left or right.

## Reference arguments

- VEX430 monobloc air handling unit, horizontal connection.
- Counterflow plate heat exchanger (AAHE certified).
- EC motors and backward curve impellers.
- 1600 m<sup>3</sup>/h.
- 50 mm dual skin insulation.
- Filtration up to ePM1 60%.
- 100% adjustable bypass.
- Anthracite grey access panel.
- Multiple possibilities for built-in coils.
- Control options: 0-10V, constant pressure, constant airflow.
- Integrated web server.
- BMS via Modbus RTU.

## Air handling unit

11060828  
VEX430

## Main characteristics

- pre-cabled monobloc unit,
- self-supporting construction with dual-wall panels,
- 50 mm mineral wool insulation, 40 kg/m<sup>3</sup> density,
- counterflow plate heat exchanger (up to 90% efficient) (AAHE certified),
- EC motor and backward curve impeller,
- adjustable by-pass control,
- G4 flat filters (Coarse 60%) or M5 (ePM10 50%) on extraction, F7 (ePM1 60%) or M5 (ePM10 50%) on fresh air and G4 pre-filters (Coarse 65%),
- filter clogging monitored by pressure switch,
- built-in external switch,
- wide range of coils,
- Aldes Classic control on calendar management:
  - constant speed (3 speeds),
  - variable speed according to CO<sub>2</sub>/VOC (0-10V signal)
  - constant airflow and constant pressure optional.
- configuration & monitoring via:
  - wired remote control,
  - BMS via Modbus RTU RS485 protocol
- defrosting by bypass or optional electrical defrosting coil.

## Supplementary characteristics

- coil options:
  - electrical,
  - electrical post-heating,
  - hot water with or without 3-way valve,
  - cold water with or without 3-way valve,
  - reversible (hot/cold) water with or without 3-way valve.
- access to all components on the main panel via hinged, removable doors and to control system via a specific central hatch,
- Aluminium condensate collection tray,
- Factory-mounted cowl for outdoor versions,
- M0 galvanised steel Z275 interior and exterior finishes.

## Accessories

Désignations	References
Sens CO2 sensor	11017090
VEX530 rain hood	11069034
Flexible sleeve rectangular/circular D355 VEX430/530	11069050
Adapter piece rectangular - circular VEX430/530	11072347
Motorised shut-off damper VEX430, VEX530 and VEX640	11069018
Motor Sfa-S2 On/Off 24/230V	11055045
Standalone detector trip device 230/24V	11906103
Smoke sensor	11058417
Flexible sleeve MS Pro rectangular 710x310 mm VEX430 VEX530	11069090

## Consumables

Désignations	References
F7 flat filter VEX430/630an 640ae 530	11069058
G4 flat filter kit VEX630an 640ae 430/530	11069066
M5 pre-filter kit Fresh Air (AN) / Extract air (AE) for VEX430	11100554

## Options

base
C69385
CO2
DEBCON
E69393
EXTER
F69385

Air handling unit

## 11060828

### VEX430

#### Options

F7
G4
G4F7
G69374
L69374
M5_R
M5_S
PRECON
PRESS
S69374
S69385
S69393

#### Associated services

Commissioning

#### General data

References	Insulation density (kg/m <sup>3</sup> )	Thickness of insulation (mm)	Available filters	Connection direction	Type of exchanger	Type of motor	Type of impeller
11060828	40	50	Coarse 65%, ePM1 50%, ePM1 60%	Horizontal	With plates	EC	Backward curve

#### Dimensional data

References	A (mm)	B (mm)	C (mm)	F (mm)	G (mm)	H (mm)	Weight (kg)
11060828	1822	910	954	740	340	1157	291

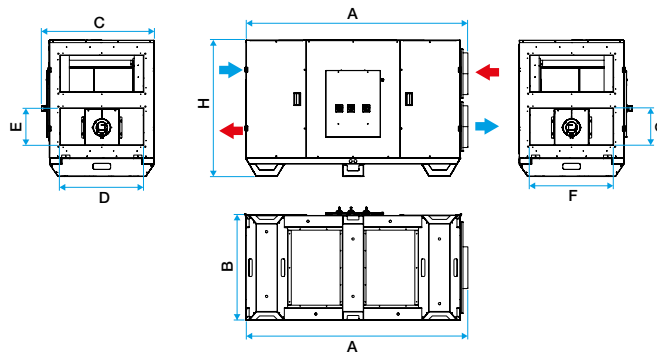

Dimensions VEX400

Dimensions are given as a guide only. Make your selection in the Selector VEX software to obtain the actual characteristics of your unit.

#### Airflow data

References	Max. airflow (m <sup>3</sup> /h)
11060828	1870

#### Thermal data

References	Max. exchanger output (%)	Max. current absorbed (kW)
11060828	90	0,96

#### Electrical datas

References	Max. power of electrical coil 1 (kW)	Max. electrical output of unit (kW)	Electrical coil voltage 1	Unit voltage (V)
11060828	5.61	0,96	3x400	230

Air handling unit

## 11060828

### VEX430

### Curve

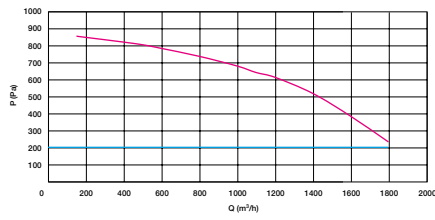

- > Aeraulic curves drawn up as per standard NF EN ISO 5801.
- > P (Pa) = static pressure.
- > P (W) = power consumption.

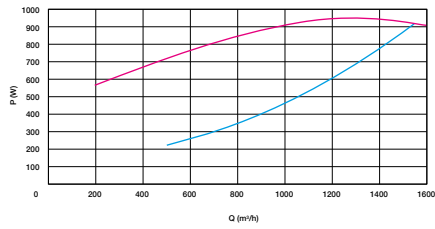

Airflow and power VEX430