

Air handling unit

11069188
VEX530-C4

VEX500-C4 is the air handling unit solution for bedrooms. It delivers a very good indoor air quality, a high level of comfort and restricts energy losses to a minimum.



VEX500-C4

PRODUCT BENEFITS

- the safety of C4 blended with the benefits of very high efficiency air handling (up to 95%),
- exclusive Aldes Smart Control® system,
- optimum air quality and thermal comfort.

REGLEMENTATIONS AND COMPLIANCES

Eurovent Certification no. : 13.03.001

Principles of operation

VEX500-C4 brings fresh, filtered air (up to 90% of PM1) into the building and recovers heat from exhaust air using its very high-efficiency heat exchanger. The incoming air can be heated and/or cooled using a full range of coils.

Product description

VEX500-C4 is the ideal high-performance solution for multi-occupancy housing and non-residential accommodation. Thanks to its very high-performance heat exchanger, its wide range of filters and coils, building occupants enjoy very good indoor air quality (up to ePM1 90%) alongside excellent thermal and acoustic comfort. VEX500-C4 also severely restricts energy losses to a minimum (up to 95% efficiency on Eurovent AAHE-certified heat exchanger).

Fields of application

Multi-occupancy residential housing, New, Refurbishment, Non-residential buildings

Installation

- equipment rooms / flat roofs,
- indoors / outdoors,
- in-line duct connections,
- rectangular connectors (circular adapters available as accessories),
- choice of utility connections side - left or right.

Reference arguments

- VEX530-C4 monobloc air handling unit with horizontal connection,
- C fire certification,
- High-efficiency counterflow plate heat exchanger (AAHE certified),
- EC motor and backward curve impellers,
- 1600 m³/h,
- 50 mm dual skin insulation,
- Filtration up to ePM1 90%,
- 100% adjustable bypass,
- Anthracite grey access panel,
- Multiple possibilities for built-in coils,
- Aldes Smart Control system,
- Integrated web server,
- BMS via Modbus RTU and Bacnet TCP/IP.

Air handling unit

11069188
VEX530-C4

Main characteristics

- C4 solution: 400 °C 1/2 hour (Ø 160mm)
- pre-wired monobloc unit featuring self-supporting construction with dual-wall panels,
- 50 mm mineral wool insulation, density 40 kg/m³,
- high-efficiency counterflow plate heat exchanger up to 95% (AAHE-certified),
- EC motor and high-performance backward curve impeller,
- 100 % and adjustable bypass control,
- G4 filters (Coarse 60%) on exhaust, F7 (ePM1 60%) on fresh air,
- optional: M5 (ePM10 50%), F9 (ePM1 90%),
- wide range of coils,
- built-in switch,
- Aldes Smart Control® system:
 - constant speed,
 - constant airflow,
 - constant pressure,
 - variable airflow according to CO2/VOC probe (0-10V signal)
 - pressure control: adapts pressure to airflow measured, for very high energy efficiency,
 - built-in clock: timer control,
 - configuration & monitoring via:
 - remote touch-screen control,
 - web server,
 - BMS via ModbusRTU, Bacnet, TCP/IP.
- defrosting by electrical coil on exhaust air or by imbalancing the bypass.

Supplementary characteristics

- coil options:
 - electrical,
 - electrical post-heating,
 - hot water with or without 3-way valve,
 - cold water with or without 3-way valve,
 - reversible (hot/cold) water with or without 3-way valve.
- aluminium or galvanised steel + paint condensate collection tray on heat exchanger,
- monobloc roof piece fitted in factory for outdoor versions,
- access to all components on the main panel via hinged, removable doors, and to control system via a specific central hatch,
- steel access doors pre-coated in dark grey (RAL 7016),
- galvanised steel or pre-coated external finish (RAL 9006) depending on the version,
- M0 interior finishes made of Z275 galvanised steel.

Accessories

Désignations	References
VEX530 rain hood	11069034
Flexible sleeve rectangular/circular D355 VEX430/530	11069050
Rigid adapter piece VEX530	11069042
Flexible sleeve MS Pro rectangular 710x310 mm VEX430 VEX530	11069090

Consumables

Désignations	References
F7 flat filter VEX430/630an 640ae 530	11069058
G4 flat filter kit VEX630an 640ae 430/530	11069066
F7 HE flat filter kit VEX530 AN	11069074
M5 pre-filter kit Fresh Air (AN) / Extract air (AE) for VEX430	11100554
F9 flat filter kit VEX530/VEX630	11100740

Options

base
C69385
CO2
DEBCON

Air handling unit

11069188

VEX530-C4

Options

E69393
EXTENSION
EXTER
F69385
F7
F7+F9
FILAIRE
G4+F9
G4_S
G69374
HAUTEFF
L69374
M5+F7
M5+F7HE
M5+F9
M5_R
M5_S
PRECON
PREDEBCON
PREFILTRE
PREFILTRE2
PRESS
S69374
S69385
S69393
TACTILE
ZAS024

Associated services

Commissioning

General data

References	Insulation density (kg/m ³)	Thickness of insulation (mm)	Available filters	Connection direction	Type of exchanger	Type of motor
11069188	40	50	Coarse 65%, ePM10 50%, ePM1 60%, ePM1 90%	Horizontal	With plates	EC

Dimensional data

References	A (mm)	B (mm)	C (mm)	D (mm)	E (mm)	F (mm)	G (mm)	H (mm)	Weight (kg)
11069188	1823	937	907	710	310	740	340	1470	291

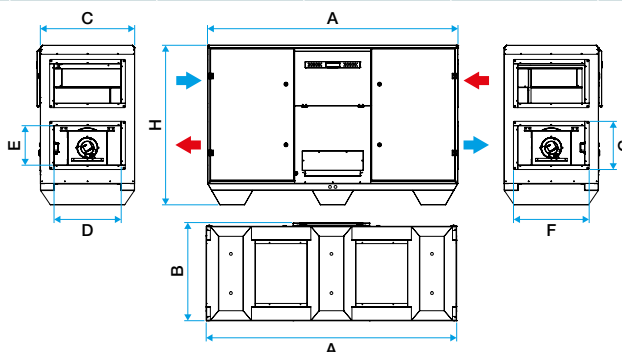

Dimensions VEX500-C4

Dimensions are given as a guide only. Make your selection in the Selector VEX software to obtain the actual characteristics of your unit.

Airflow data

References	Minimum airflow	Max. airflow (m ³ /h)
11069188	320	1600

Air handling unit

11069188

VEX530-C4

Thermal data

References	Max. exchanger output (%)	Max. current absorbed (kW)
11069188	95	1,011

Electrical datas

References	Max. power of electrical coil 1 (kW)	Max. electrical output of unit (kW)	Electrical coil voltage 1	Unit voltage (V)
11069188	5.61	0,98	3x400	230

Regulatory data

References	Test values as per standard EN 1886
11069188	D1, L2, F7, T3, TB2

Curve

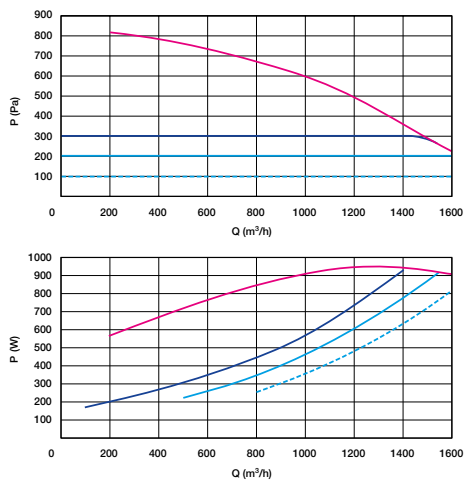

- > Aerulic curves drawn up as per standard NF EN ISO 5801.
- > P (Pa) = static pressure.
- > P (W) = power consumption.

Débit et puissance VEX530