

Air handling unit

11069194
VEX590

VEX500 is the air handling unit solution that delivers very good indoor air quality (ePM1 filter 90%) and a high level of comfort while limiting energy losses to a minimum.



VEX500

PRODUCT BENEFITS

- air handling units producing very high efficiency (up to 95%),
- exclusive Aldes Smart Control® system,
- optimal air quality and thermal comfort,

REGLEMENTATIONS AND COMPLIANCES

Eurovent Certification no. : 13.03.001

Principles of operation

VEX500 brings fresh, filtered air (up to 90% of PM1) into the building and recovers heat from exhaust air using its very high-efficiency heat exchanger. The incoming air can be heated and/or cooled using a full range of coils.

Product description

VEX400 is the ideal high-performance solution for small non-residential buildings. Thanks to its very high-performance heat exchanger, its wide range of filters and coils, building occupants enjoy very good indoor air quality (up to ePM1 90%) alongside excellent thermal and acoustic comfort. VEX400 also severely restricts energy losses to a minimum (up to 95% efficiency on Eurovent AAHE-certified heat exchanger).

Fields of application

New, Refurbishment, Non-residential buildings

Installation

- equipment rooms / flat roofs,
- indoors / outdoors,
- in-line duct connections,
- rectangular connectors (circular adapters available as accessories),
- choice of utility connections side - left or right.

Reference arguments

- VEX590 monobloc air handling unit, horizontal connection.
- High-efficiency counterflow plate heat exchanger (AAHE certified)
- EC motor and backward curve impellers
- 8700 m³/h,
- 50 mm dual skin insulation
- Filtration up to ePM1 90%
- 100% adjustable bypass
- Anthracite grey access panel.
- Multiple possibilities for built-in coils
- Aldes Smart Control system
- Integrated web server.
- BMS via Modbus RTU and Bacnet TCP/IP.
- Available in pre-coated version.

Air handling unit

11069194
VEX590

Main characteristics

- pre-wired monobloc unit featuring self-supporting construction with dual-wall panels,
- 50 mm mineral wool insulation, density 40 kg/m³,
- high-efficiency counterflow plate heat exchanger up to 95% (AAHU-certified),
- EC motor and high-performance backward curve impeller,
- 100 % and adjustable bypass control,
- G4 filters (Coarse 60%) on exhaust and F7 (ePM1 60%) on fresh air as standard,
- optional: M5 (ePM10 50%), F9 (ePM1 90%),
- wide range of coils,
- built-in switch,
- Aldes Smart Control® system:
 - constant speed,
 - constant airflow,
 - constant pressure,
 - variable airflow according to CO₂/VOC sensor (0-10 V signal),
 - pressure control: adapts pressure to airflow measured, for very high energy efficiency,
 - built-in clock: timer control.
- configuration & monitoring via:
 - remote touch-screen control,
 - built-in webserver,
 - BMS via ModbusRTU, Bacnet, TCP/IP.
- de-icing by electrical coil on exhaust air or by controlled bypass opening

Supplementary characteristics

- coil options:
 - electrical,
 - electrical post-heating,
 - hot water with or without 3-way valve,
 - cold water with or without 3-way valve,
 - reversible (hot/cold) water with or without 3-way valve.
- aluminium or galvanised steel + paint condensate collection tray on heat exchanger,
- monobloc roof piece fitted in factory for outdoor versions,
- access to all components on the main panel via hinged, removable doors, and to control system via a specific central hatch,
- steel access doors pre-coated in dark grey (RAL 7016),
- galvanised steel or pre-coated external finish (RAL 9006) depending on the version,
- M0 interior finishes made of Z275 galvanised steel.

Accessories

Désignations	References
Smoke sensor	11058417
Sens CO ₂ sensor	11017090

Associated services

Commissioning

General data

References	Insulation density (kg/m ³)	Thickness of insulation (mm)	Type of motor
11069194	40	50	EC

Air handling unit

11069194

VEX590

Dimensional data

References	H (mm)
11069194	1693

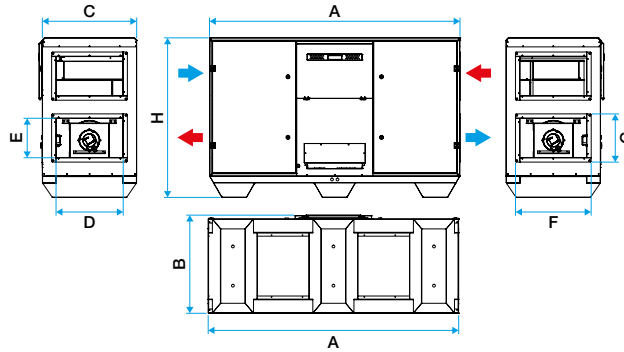

Dimensions VEX500

Dimensions are given as a guide only. Make your selection in the Selector VEX software to obtain the actual characteristics of your unit.

Airflow data

References	Max. airflow (m³/h)
11069194	8700

Thermal data

References	Max. exchanger output (%)
11069194	95

Electrical datas

References	Electrical coil voltage 1	Unit voltage (V)
11069194	3x400	230

Regulatory data

References	Test values as per standard EN 1886
11069194	D1, L2, F7, T3, TB2

Principe de fonctionnement



View of airflows in a VEX500

Eclaté VEX500

Air handling unit

11069194

VEX590

- > Aeraulic curves drawn up as per standard NF EN ISO 5801.
- > P (Pa) = static pressure
- > P (W) = power consumption.